

CTS01

SWL - 150kg

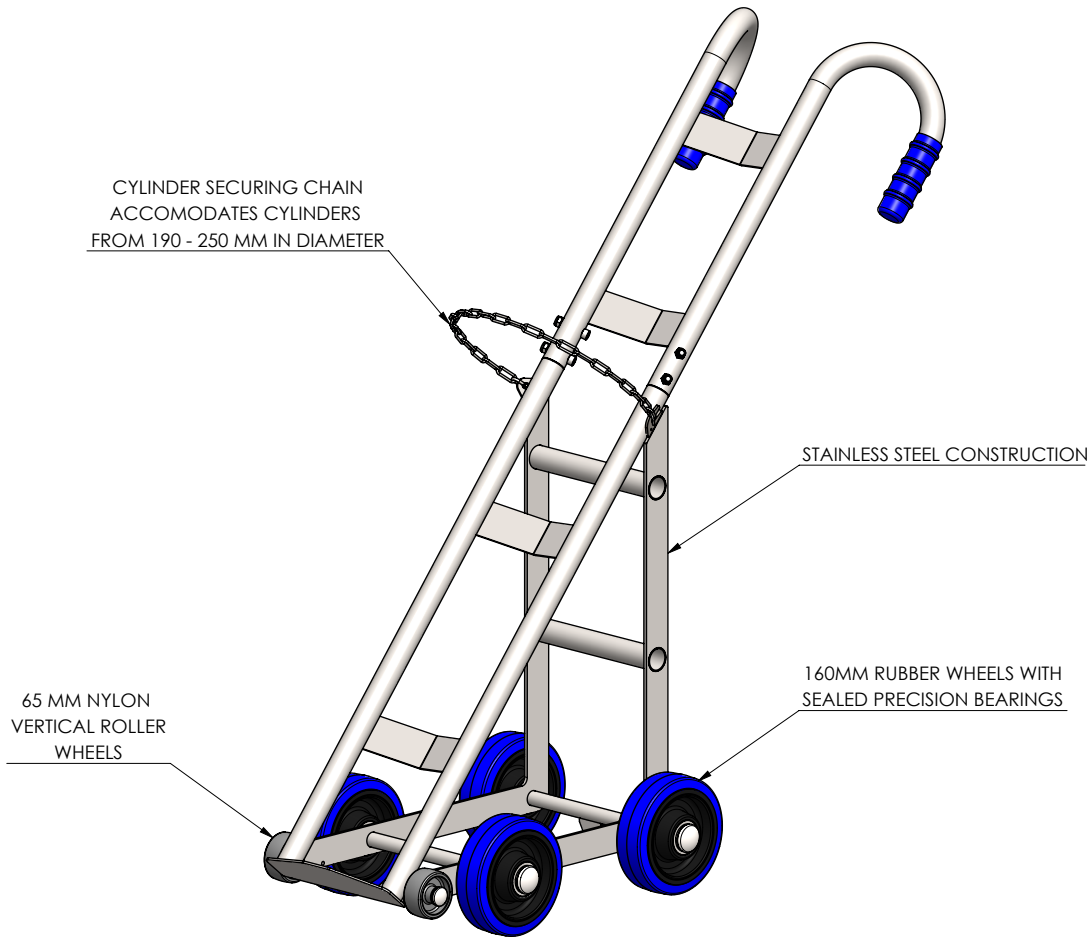

65 MM NYLON
VERTICAL ROLLER
WHEELS

CYLINDER SECURING CHAIN
ACCOMODATES CYLINDERS
FROM 190 - 250 MM IN DIAMETER

STAINLESS STEEL CONSTRUCTION

160MM RUBBER WHEELS WITH
SEALED PRECISION BEARINGS

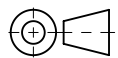

THIRD ANGLE
PROJECTION

ALL DIMENSIONS
IN mm U.O.S

DO NOT SCALE

UNLESS OTHERWISE SPECIFIED THE FOLLOWING APPLY:
FABRICATED COMPONENTS DIMENSIONAL PRECISION

DECIMAL	METRIC	IMPERIAL	ANGLE	SIZE
0.0	±1.20mm	±0.05"	±0.50°	SIZE ≤ 1000MM
0.0	±0.80mm	±0.03"	±0.25°	SIZE ≤ 1000MM
0.0	±2.5mm	±0.10"	±0.50°	SIZE > 1000MM
0.0	±1.5mm	±0.06"	±0.25°	SIZE > 1000MM

STANDARD SURFACE FINISH RA 63MM [RA 250MIN]
BREAK ALL SHARP CORNERS AND EDGES, R 0.3mm MAX

THIS DOCUMENT AND ALL THE INFORMATION CONTAINED HEREIN ARE CONFIDENTIAL AND EXCLUSIVE PROPERTY OF STS BESPOKE HANDLING EQUIPMENT AND MAY NOT BE REPRODUCED, USED, DISCLOSED OR MADE PUBLIC IN ANY MANNER PRIOR TO EXPRESS WRITTEN AUTHORISATION BY STS BESPOKE HANDLING EQUIPMENT.
THIS DOCUMENT IS ACCEPTED PURSUANT TO AGREEMENT TO THE FOREGOING, AND MUST BE RETURNED OR DESTROYED UPON DEMAND.
MANUFACTURER AGREES THAT ARTICLES MADE IN ACCORDANCE WITH THIS DOCUMENT SHALL BE CONSIDERED STS BESPOKE HANDLING EQUIPMENT'S DESIGN AND THAT IDENTICAL ARTICLES OR PARTS THEREOF SHALL NOT BE MANUFACTURED FOR THE USE OR SALE BY THE MANUFACTURER OR ANY OTHER PERSON OR ENTITY WITHOUT PRIOR EXPRESS WRITTEN AUTHORISATION BY STS BESPOKE HANDLING EQUIPMENT.

CATEGORY: ASSEMBLY

MATERIAL SPEC:

FINISH: N/A

DESCRIPTION: CYLINDER TROLLEY, CTS01, ASSEMBLY, STAINLESS STEEL

SHEET NO: 1 OF 2

EST MASS: 15.81kg

SHEET SIZE: A4

PART NUMBER:
020553

DRAWN BY: JC

CHECKED BY: JC



DATE
CHK: 20/07/2023

REVISION:
A

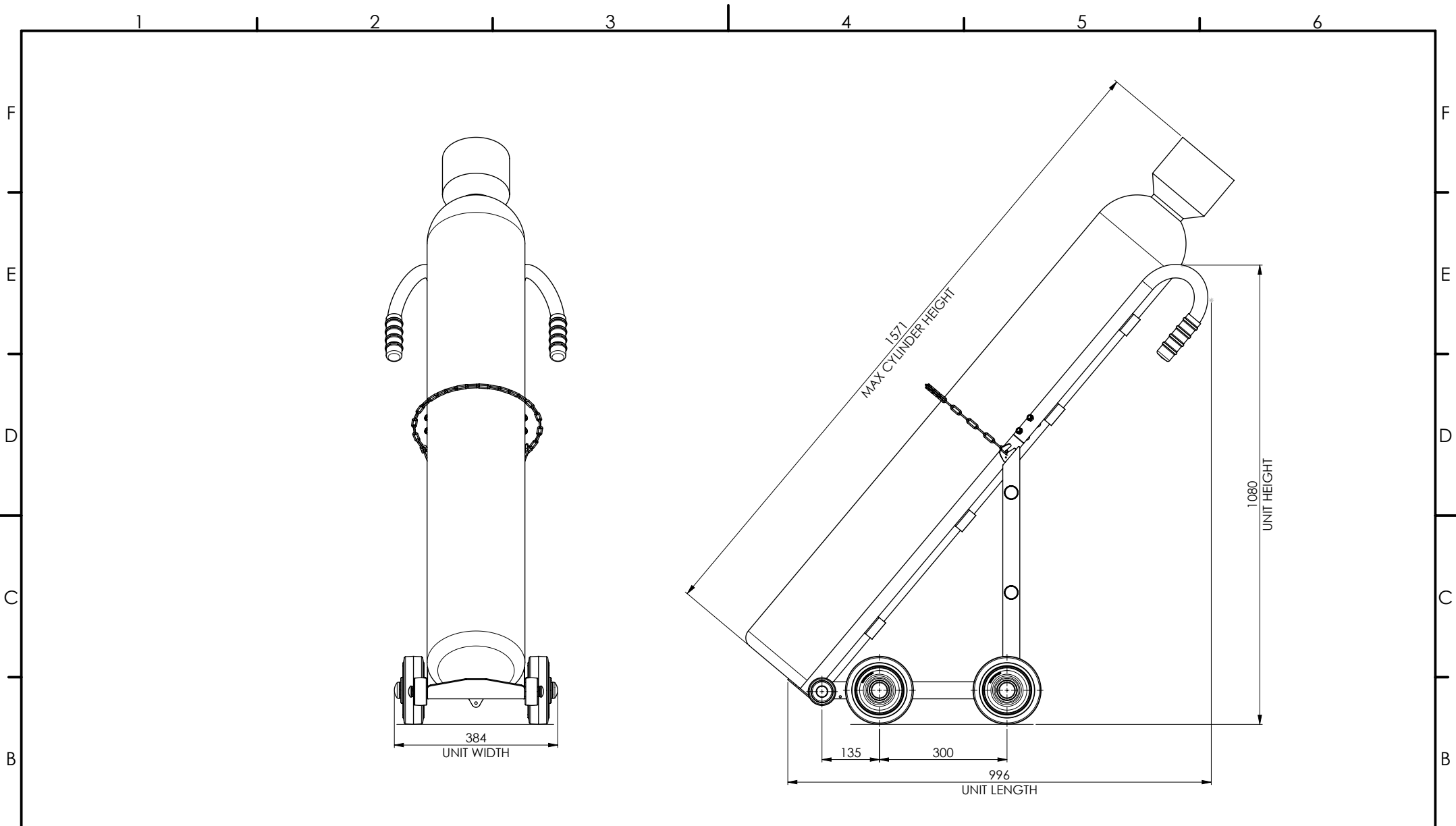

BESPOKE HANDLING EQUIPMENT LTD
LEEDSTOWN, CORNWALL, TR27 6DS
TEL: +44 1736 85 10 50 FAX: +44 1736 85 10 23
E-MAIL: SALES@STS-TROLLEYS.CO.UK
WWW: HTTPS://WWW.STS-TROLLEYS.CO.UK



 THIRD ANGLE PROJECTION	ALL DIMENSIONS IN mm U.O.S	UNLESS OTHERWISE SPECIFIED THE FOLLOWING APPLY: FABRICATED COMPONENTS DIMENSIONAL PRECISION DECIMAL METRIC IMPERIAL ANGLE 0.0 ±1.20mm ±0.05" ±0.50° 0.0 ±0.80mm ±0.03" ±0.25° 0.0 ±2.5mm ±0.10" ±0.50° 0.0 ±1.5mm ±0.06" ±0.25° STANDARD SURFACE FINISH RA 63MM [RA 250MIN] BREAK ALL SHARP CORNERS AND EDGES, R 0.3mm MAX	CATEGORY: ASSEMBLY	SHEET NO: 2 OF 2	DRAWN BY: JC
	DO NOT SCALE		MATERIAL SPEC:	EST MASS: 15.81kg	CHECKED BY: JC
 BESPOKE HANDLING EQUIPMENT LTD LEEDSTOWN, CORNWALL TR27 6DS TEL: +44 1736 85 10 50 FAX: +44 1736 85 10 23 E-MAIL: SALES@STS-TROLLEYS.CO.UK WWW: HTTPS://WWW.STS-TROLLEYS.CO.UK	FINISH: N/A	SHEET SIZE: A4	DATE CHK: 20/07/2023		
	DESCRIPTION: CYLINDER TROLLEY, CTS01, ASSEMBLY, STAINLESS STEEL	PART NUMBER: 020553	REVISION: A		