

DME02-230V-25RPM-Ex

SWL - 300kg

4X LIFTING POINTS FOR POSITIONING THE MIXER

SHOT BLASTED, ZINC PRIMER & POWDERCOATED FINISH

CONDUCTIVE DRUM ROLLER WHEELS DESIGNED TO MIX 560MM TO 600MM DIAMETER DRUMS, UP TO 1040MM TALL

CLEAN, MILD STEEL CONSTRUCTION

230V SINGLE PHASE ATEX RATED CONTROL PANEL WITH Ex d ENCLOSURE

STEEL AND ANTI-STATIC POLYCARBONATE LIFT UP LID

ATEX RATED Ex d MOTOR

HYDRAULICALLY POWERED HORIZONTAL TO VERTICAL POSITIONING

10MM THICK ANTI-STATIC NYLON DRUM LOADING PLATE

MECHANICAL ASSEMBLY ATEX CODE SHOWN - ELECTRICAL COMPONENTS/ASSEMBLIES CERTIFIED SEPERATELY TO THIS LEVEL OR HIGHER

Ex II 2 G D
Ex h IIB T4 Gb
Ex h IIIB T135°C Db

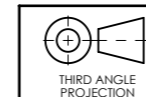

ALL DIMENSIONS IN mm U.O.S
DO NOT SCALE



BESPOKE HANDLING EQUIPMENT LTD
LEEDSTOWN, CORNWALL, TR27 6DS
TEL: +44 1736 85 10 50 FAX: +44 1736 85 10 23
E-MAIL: SALES@STIS-TROLLEYS.CO.UK
WWW: HTTPS://WWW.STIS-TROLLEYS.CO.UK

DESCRIPTION:
DME02-230V-25RPM-EX, ELECTRIC DRUM MIXER, SWL 300KG

CUSTOMER APPROVAL:
NAME:
SIGNATURE:
DATE:

THIS DOCUMENT AND ALL THE INFORMATION CONTAINED HEREIN ARE CONFIDENTIAL AND EXCLUSIVE PROPERTY OF STS BESPOKE HANDLING EQUIPMENT AND MAY NOT BE REPRODUCED, USED, DISCLOSED OR MADE PUBLIC IN ANY MANNER PRIOR TO EXPRESS WRITTEN AUTHORIZATION BY STS BESPOKE HANDLING EQUIPMENT.
THIS DOCUMENT IS ACCEPTED PURSUANT TO AGREEMENT TO THE FOREGOING, AND MUST BE RETURNED OR DESTROYED UPON DEMAND.
ARTICLES MADE IN ACCORDANCE WITH THIS DOCUMENT SHALL BE CONSIDERED STS BESPOKE HANDLING EQUIPMENT'S DESIGN AND THAT IDENTICAL ARTICLES OR PARTS THEREOF SHALL NOT BE MANUFACTURED FOR THE USE OR SALE BY THE MANUFACTURER OR ANY OTHER PERSON OR ENTITY WITHOUT PRIOR EXPRESS WRITTEN AUTHORIZATION BY STS BESPOKE HANDLING EQUIPMENT.

SHEET NO: 1 OF 4
DRAWN BY: JS
SHEET SIZE: A3
PART NUMBER: 026172

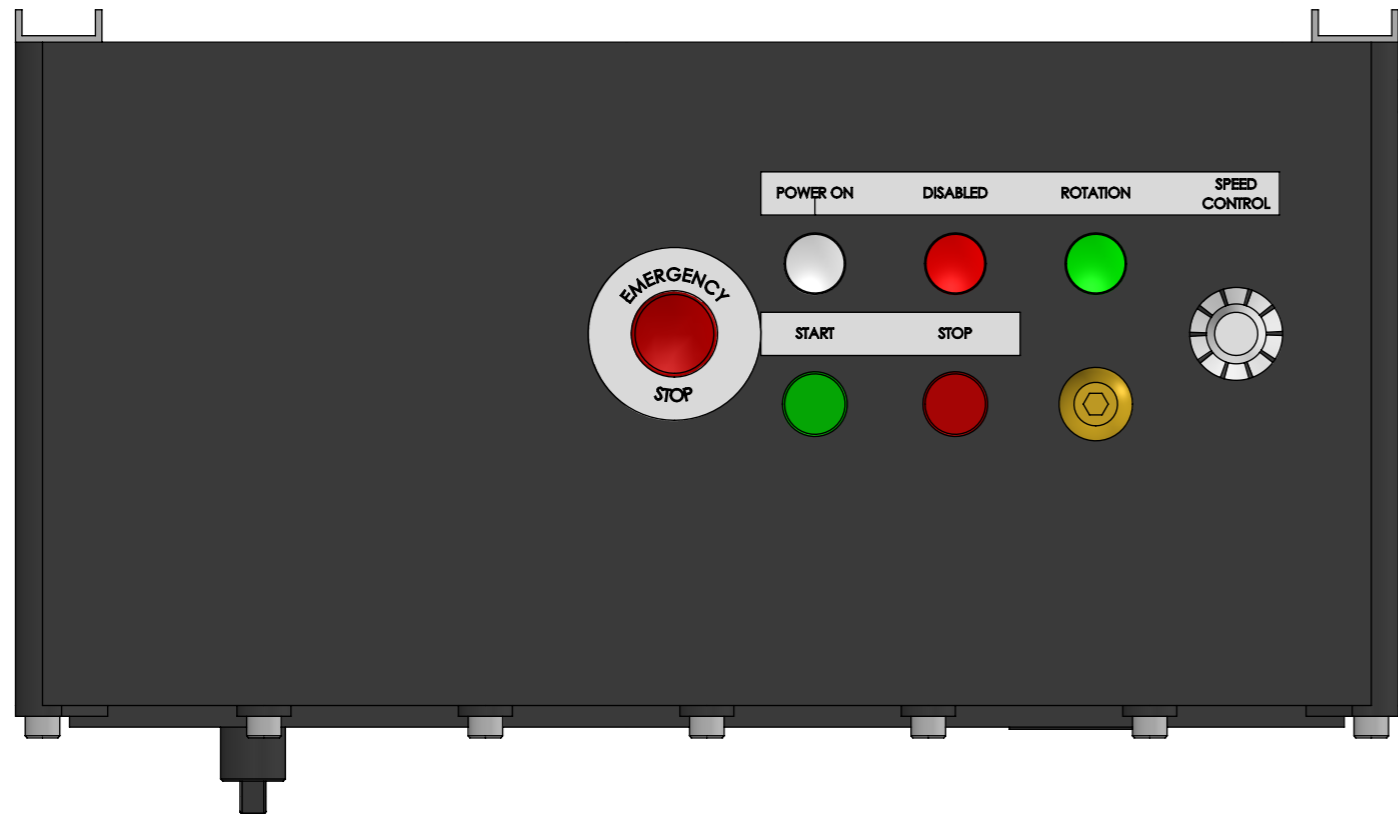

ELECTRIC CONTROL PANEL

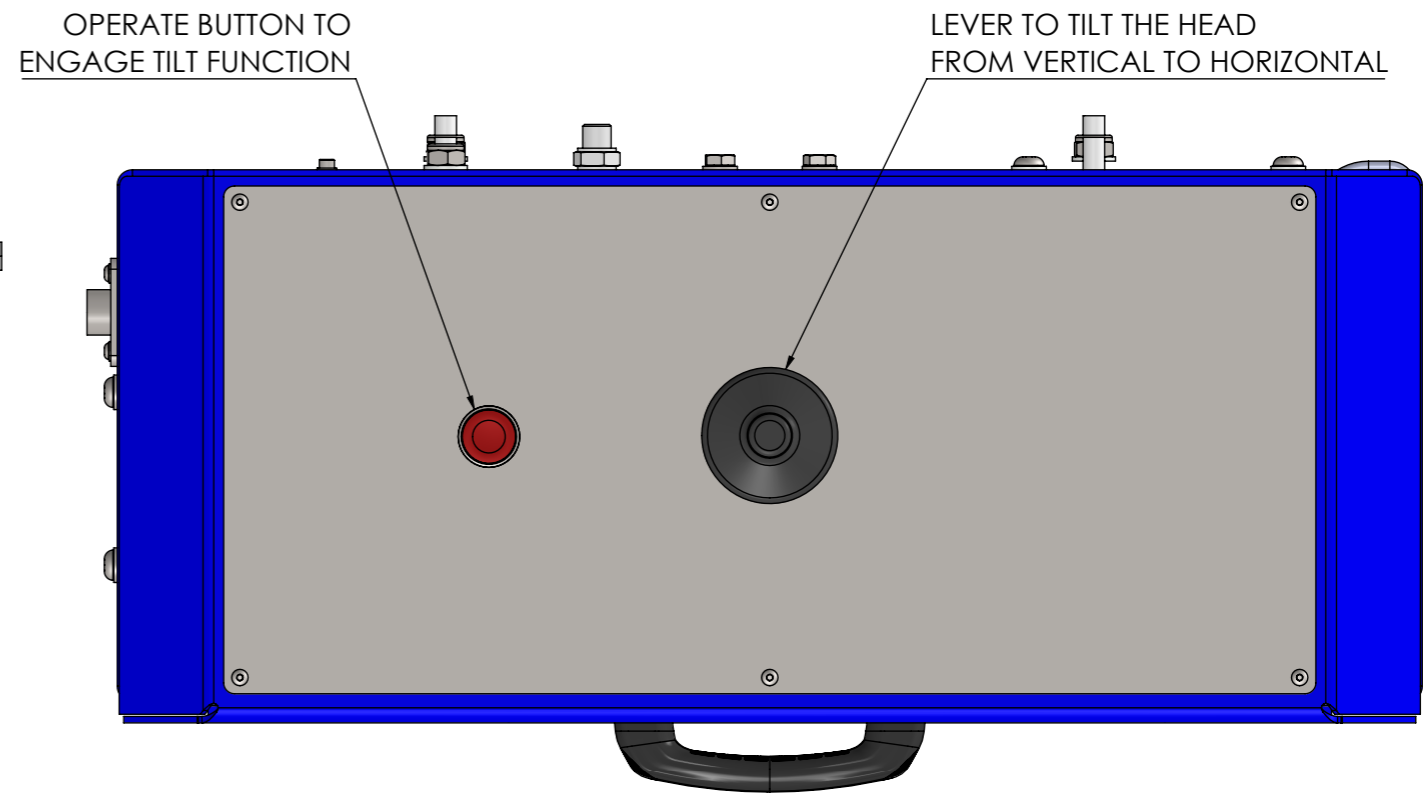



PNEUMATIC-HYDRAULIC CONTROL PANEL

PANEL LAYOUTS

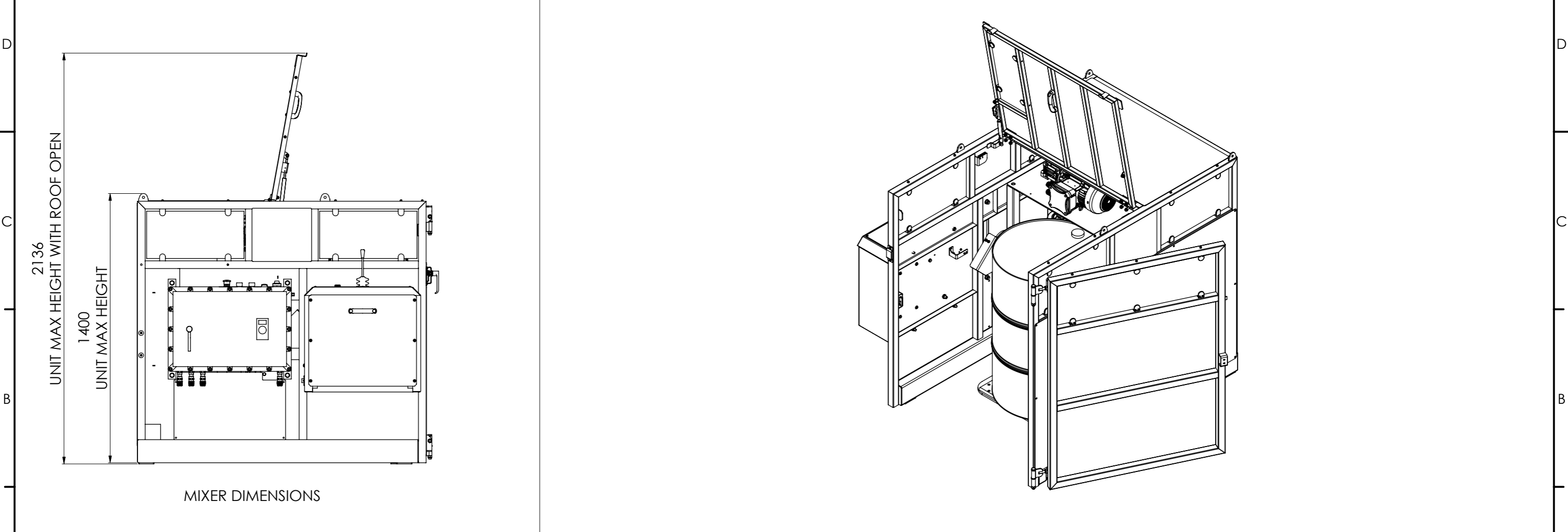
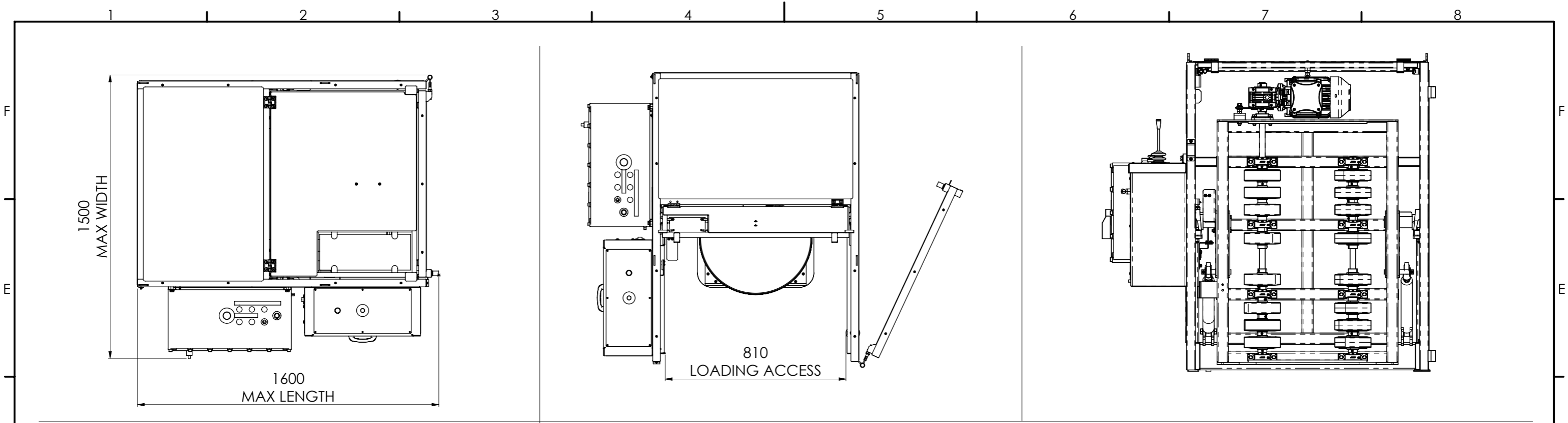
 THIRD ANGLE PROJECTION	ALL DIMENSIONS IN mm U.O.S	DESCRIPTION: DME02-230V-25RPM-EX, ELECTRIC DRUM MIXER, SWL 300KG	SHEET NO: 2 OF 4
	DO NOT SCALE		DRAWN BY: JS
 BESPOKE HANDLING EQUIPMENT LTD LEEDSTOWN, CORNWALL, TR27 6DS TEL: +44 1736 85 10 50 FAX: +44 1736 85 10 23 E-MAIL: SALES@STN-TROLLEYS.CO.UK WWW: HTTPS://WWW.STN-TROLLEYS.CO.UK		CUSTOMER APPROVAL: NAME: SIGNATURE: DATE:	SHEET SIZE: A3 PART NUMBER: 026172
		<small>THIS DOCUMENT AND ALL THE INFORMATION CONTAINED HEREIN ARE CONFIDENTIAL AND EXCLUSIVE PROPERTY OF STN BESPOKE HANDLING EQUIPMENT AND MAY NOT BE REPRODUCED, USED, DISCLOSED OR MADE PUBLIC IN ANY MANNER PRIOR TO EXPRESS WRITTEN AUTHORIZATION BY STN BESPOKE HANDLING EQUIPMENT. THIS DOCUMENT IS ACCEPTED PURSUANT TO AGREEMENT TO THE FOREGOING, AND MUST BE RETURNED OR DESTROYED UPON DEMAND. MANUFACTURER AGREES THAT ARTICLES MADE IN ACCORDANCE WITH THIS DOCUMENT SHALL BE CONSIDERED STN BESPOKE HANDLING EQUIPMENT'S DESIGN AND THAT IDENTICAL ARTICLES OR PARTS THEREOF SHALL NOT BE MANUFACTURED FOR THE USE OR SALE BY THE MANUFACTURER OR ANY OTHER PERSON OR ENTITY WITHOUT PRIOR EXPRESS WRITTEN AUTHORIZATION BY STN BESPOKE HANDLING EQUIPMENT.</small>	REVISION: 01 AUTHOR: JC AUTHORISER: NV 8 PRINTED ON: 21/07/2025

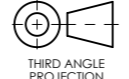

MIXER DIMENSIONS

 THIRD ANGLE PROJECTION	ALL DIMENSIONS IN mm U.O.S. DO NOT SCALE	DESCRIPTION: DME02-230V-25RPM-EX, ELECTRIC DRUM MIXER, SWL 300KG	SHEET NO: 3 OF 4
	 BESPOKE HANDLING EQUIPMENT LTD LEEDSTOWN, CORNWALL, TR27 6DS TEL: +44 1736 85 10 50 FAX: +44 1736 85 10 23 E-MAIL: SALES@STS-TROLLEYS.CO.UK WWW: HTTPS://WWW.STS-TROLLEYS.CO.UK		CUSTOMER APPROVAL: NAME: SIGNATURE: DATE:
		<small>THIS DOCUMENT AND ALL THE INFORMATION CONTAINED HEREIN ARE CONFIDENTIAL AND EXCLUSIVE PROPERTY OF STS BESPOKE HANDLING EQUIPMENT AND MAY NOT BE REPRODUCED, USED, DISCLOSED OR MADE PUBLIC IN ANY MANNER PRIOR TO EXPRESS WRITTEN AUTHORIZATION BY STS BESPOKE HANDLING EQUIPMENT. THIS DOCUMENT IS ACCEPTED PURSUANT TO AGREEMENT TO THE FOREGOING, AND MUST BE RETURNED OR DESTROYED UPON DEMAND. MANUFACTURER AGREES THAT ARTICLES MADE IN ACCORDANCE WITH THIS DOCUMENT SHALL BE CONSIDERED STS BESPOKE HANDLING EQUIPMENT'S DESIGN AND THAT IDENTICAL ARTICLES OR PARTS THEREOF SHALL NOT BE MANUFACTURED FOR THE USE OR SALE BY THE MANUFACTURER OR ANY OTHER PERSON OR ENTITY WITHOUT PRIOR EXPRESS WRITTEN AUTHORIZATION BY STS BESPOKE HANDLING EQUIPMENT.</small>	PART NUMBER: 026172

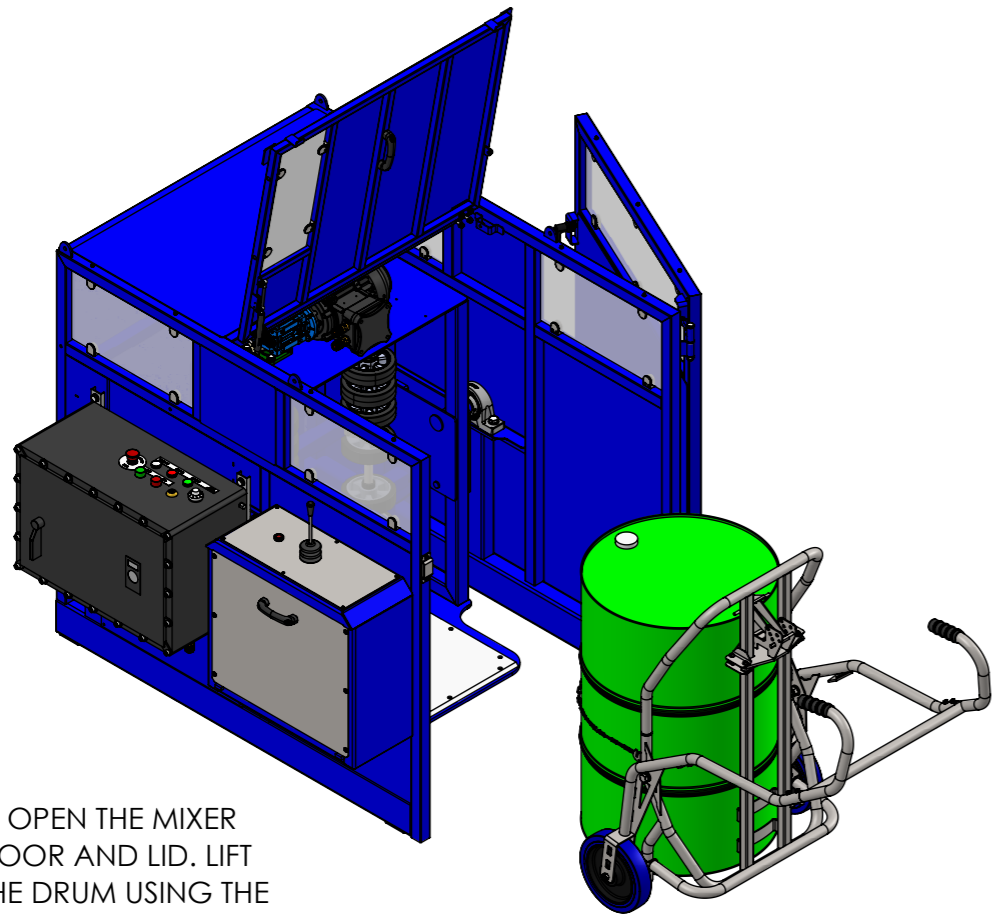

1. OPEN THE MIXER DOOR AND LID. LIFT THE DRUM USING THE DTC01 UNIVERSAL DRUM TROLLEY.

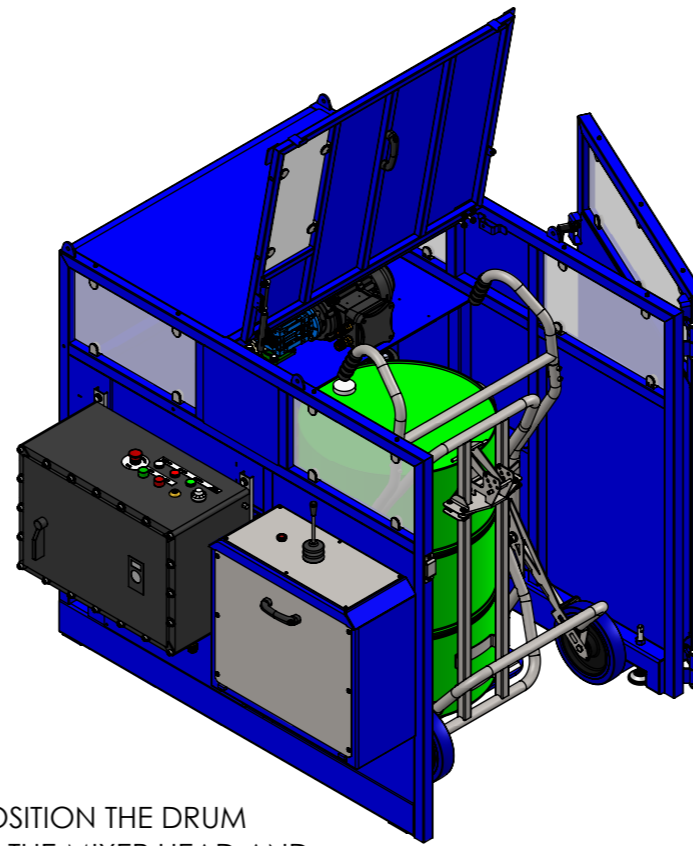

2. POSITION THE DRUM INTO THE MIXER HEAD AND DISCONNECT THE TROLLEY FROM THE DRUM.

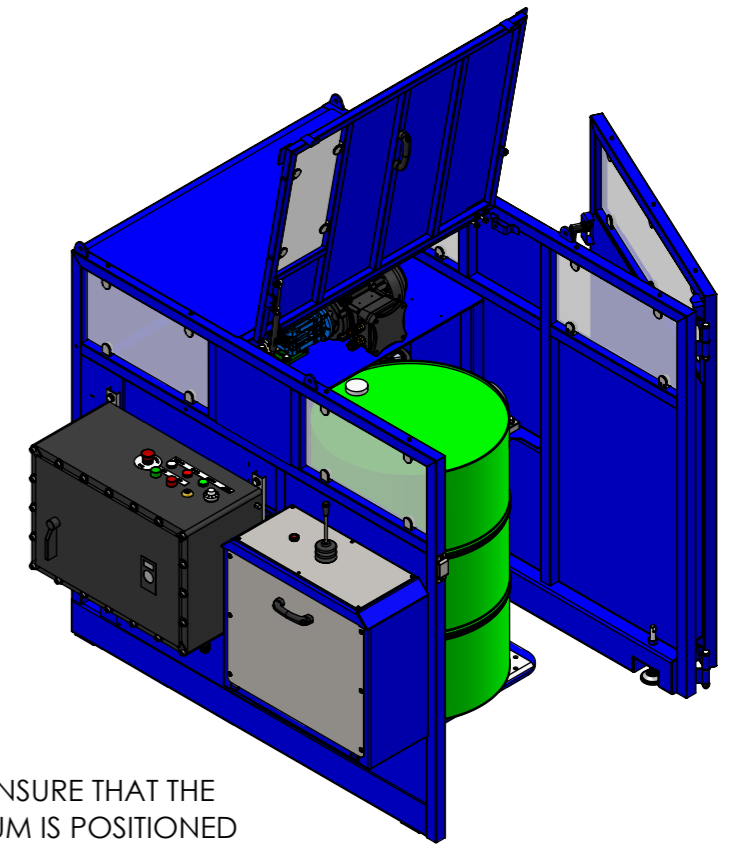

3. ENSURE THAT THE DRUM IS POSITIONED CORRECTLY AND IS TOUCHING THE ROLLER WHEELS.

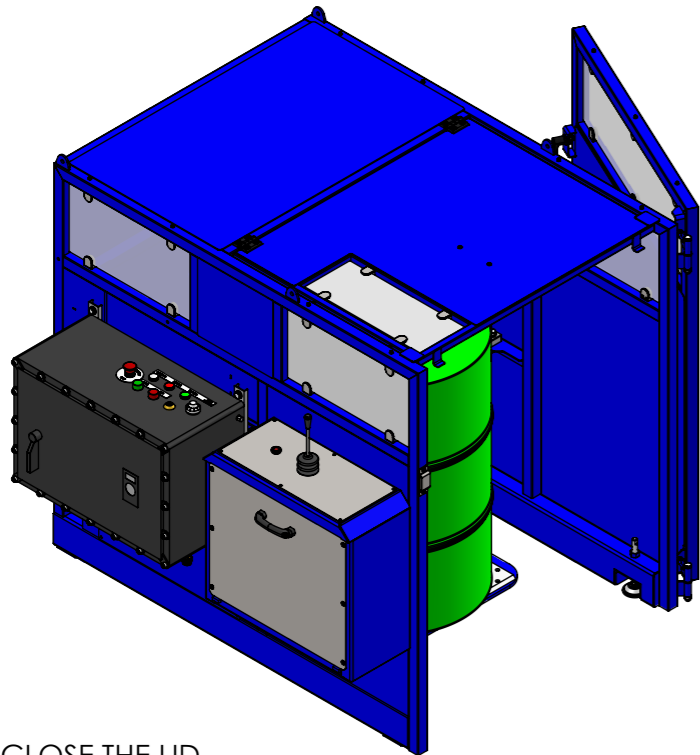

4. CLOSE THE LID.

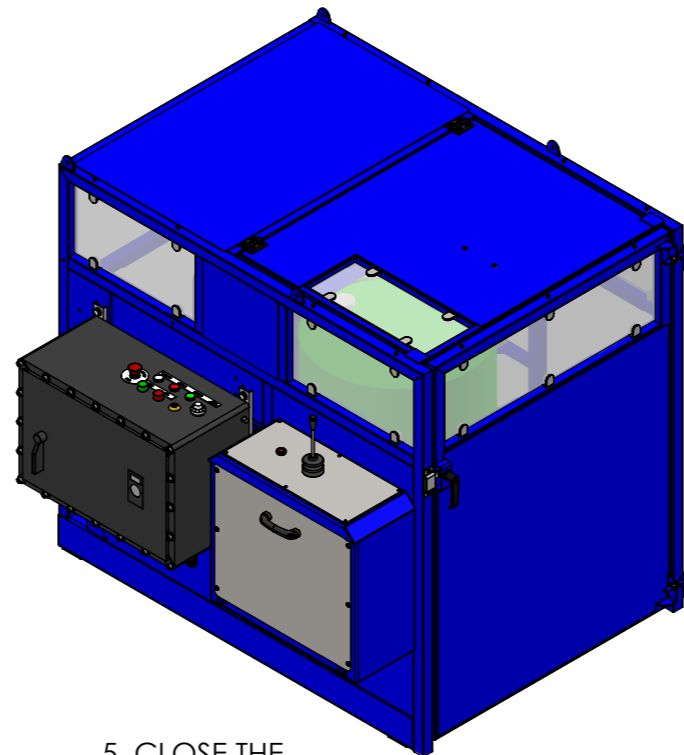

5. CLOSE THE MIXER DOOR.

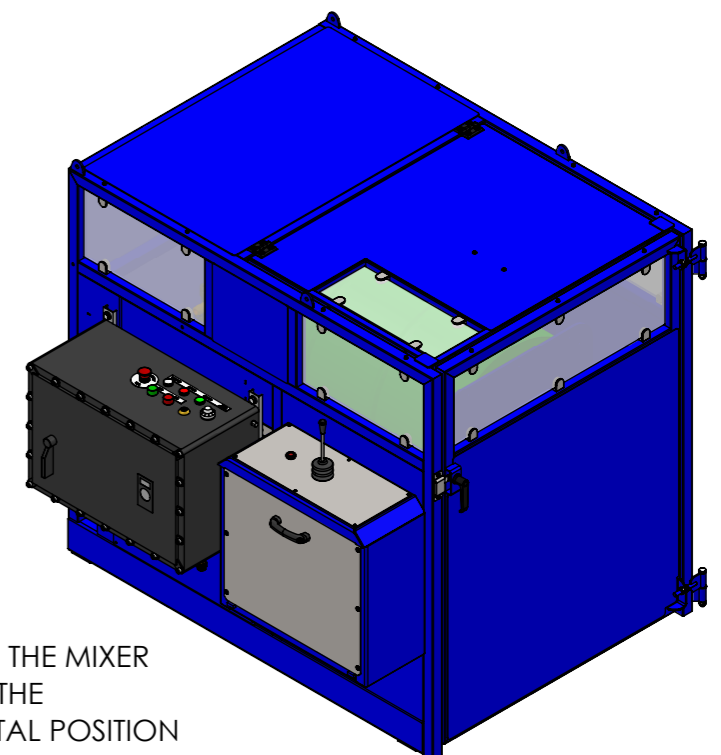

6. ROTATE THE MIXER HEAD TO THE HORIZONTAL POSITION AND START THE MIXER.

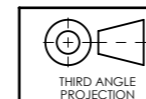

ALL DIMENSIONS
IN mm U.O.S
DO NOT SCALE



DESCRIPTION:
DME02-230V-25RPM-EX, ELECTRIC DRUM MIXER, SWL 300KG

CUSTOMER APPROVAL:
NAME:
SIGNATURE:
DATE:

THIS DOCUMENT AND ALL THE INFORMATION CONTAINED HEREIN ARE CONFIDENTIAL AND EXCLUSIVE PROPERTY OF STS BESPOKE HANDLING EQUIPMENT AND MAY NOT BE REPRODUCED, USED, DISCLOSED OR MADE PUBLIC IN ANY MANNER PRIOR TO EXPRESS WRITTEN AUTHORIZATION BY STS BESPOKE HANDLING EQUIPMENT. THIS DOCUMENT IS ACCEPTED PURSUANT TO AGREEMENT TO THE FOREGOING, AND MUST BE RETURNED OR DESTROYED UPON DEMAND. MANUFACTURER AGREES THAT ARTICLES MADE IN ACCORDANCE WITH THIS DOCUMENT SHALL BE CONSIDERED STS BESPOKE HANDLING EQUIPMENT'S DESIGN AND THAT IDENTICAL ARTICLES OR PARTS THEREOF SHALL NOT BE MANUFACTURED FOR THE USE OR SALE BY THE MANUFACTURER OR ANY OTHER PERSON OR ENTITY WITHOUT PRIOR EXPRESS WRITTEN AUTHORIZATION BY STS BESPOKE HANDLING EQUIPMENT.

SHEET NO: 4 OF 4
DRAWN BY: JS
SHEET SIZE: A3
PART NUMBER:
026172