

DTP08-250kg-R500-SS

SWL - 250kg

CLEAN STAINLESS-STEEL CONSTRUCTION WITH AN VIBRA-POLISHED FINISH

MANUAL HYDRAULIC LIFT HAND PUMP AND TANK WITH THROTTLING LOWERING VALVE

CLEAR POLYCARBONATE GUARDING

ADJUSTABLE CATCH FOR 50-220L STEEL AND PLASTIC DRUMS

RACK OFFERS VERTICAL HEIGHT ADJUSTMENT FOR DIFFERENT DRUM SIZES



500MM STROKE HYDRAULIC RAM FITTED WITH BURST VALVE

TILLER HANDLE WITH SPRING RETURN

BRAKED SINGLE WHEEL REAR STEERING

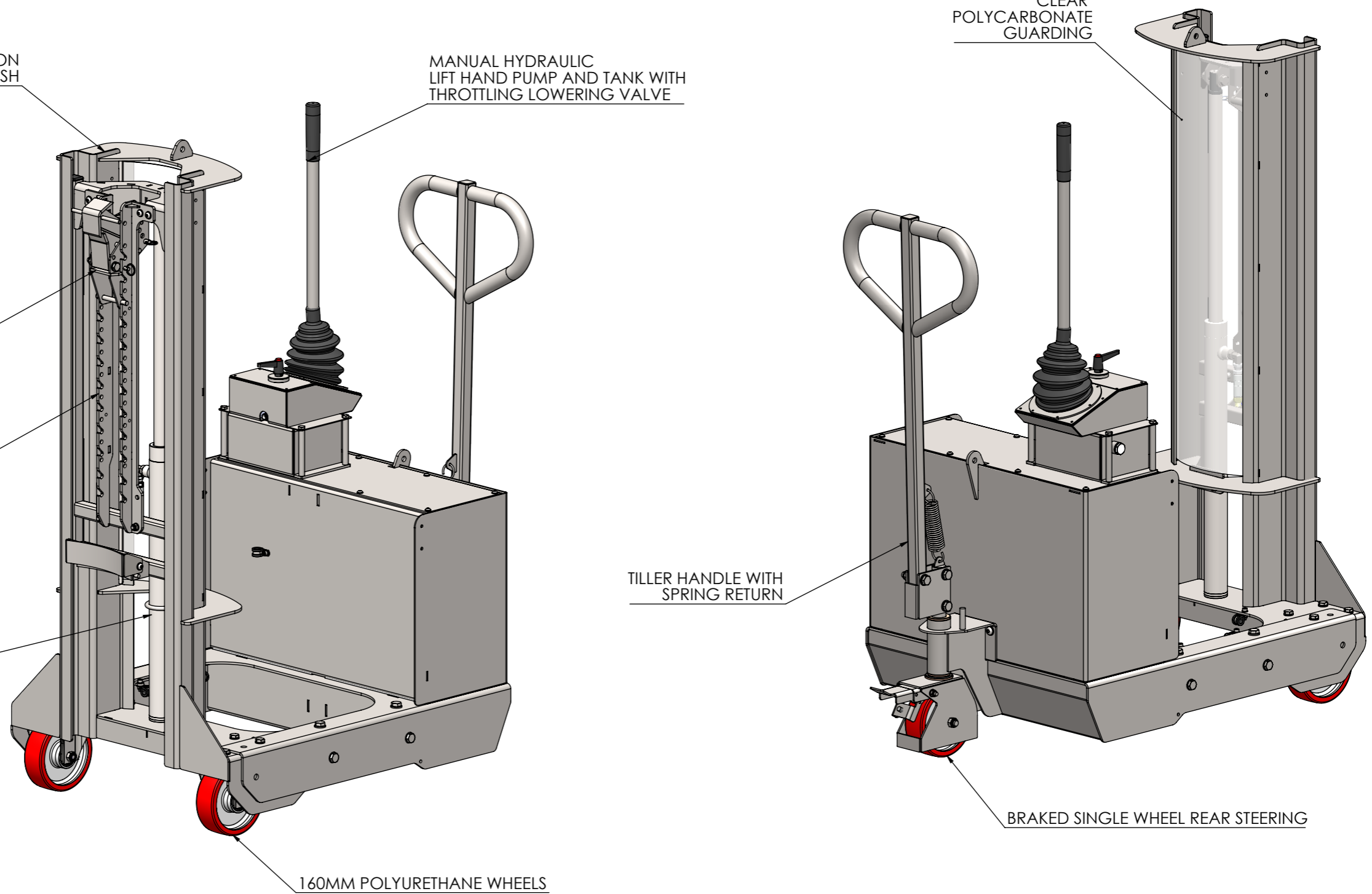
160MM POLYURETHANE WHEELS

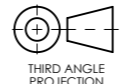

 THIRD ANGLE PROJECTION	ALL DIMENSIONS IN mm U.O.S	DESCRIPTION: DTP08-250KG-R500-SS, DEPALLETISER, 500MM STROKE, 250KG SWL	SHEET NO: 1 OF 4
	DO NOT SCALE		DRAWN BY: JC
 BESPOKE HANDLING EQUIPMENT LTD LEEDSTOWN, CORNWALL, TR27 6DS TEL: +44 1736 85 10 50 FAX: +44 1736 85 10 23 E-MAIL: SALES@STS-TROLLEYS.CO.UK WWW: HTTPS://WWW.STS-TROLLEYS.CO.UK	CUSTOMER APPROVAL: NAME: SIGNATURE: DATE:		SHEET SIZE: A3
	<small>THIS DOCUMENT AND ALL THE INFORMATION CONTAINED HEREIN ARE CONFIDENTIAL AND EXCLUSIVE PROPERTY OF STS BESPOKE HANDLING EQUIPMENT AND MAY NOT BE REPRODUCED, USED, DISCLOSED OR MADE PUBLIC IN ANY MANNER PRIOR TO EXPRESS WRITTEN AUTHORIZATION BY STS BESPOKE HANDLING EQUIPMENT. THIS DOCUMENT IS ACCEPTED PURSUANT TO AGREEMENT TO THE FOREGOING, AND MUST BE RETURNED OR DESTROYED UPON DEMAND. MANUFACTURER AGREES THAT ARTICLES MADE IN ACCORDANCE WITH THIS DOCUMENT SHALL BE CONSIDERED STS BESPOKE HANDLING EQUIPMENT'S DESIGN AND THAT IDENTICAL ARTICLES OR PARTS THEREOF SHALL NOT BE MANUFACTURED FOR THE USE OR SALE BY THE MANUFACTURER OR ANY OTHER PERSON OR ENTITY WITHOUT PRIOR EXPRESS WRITTEN AUTHORIZATION BY STS BESPOKE HANDLING EQUIPMENT.</small>		PART NUMBER: 022509
			REVISION: 01 AUTHOR: JC AUTHORISER: NV

1 2 3 4 5 6 7 8

F F

E E



D D

C C

B B

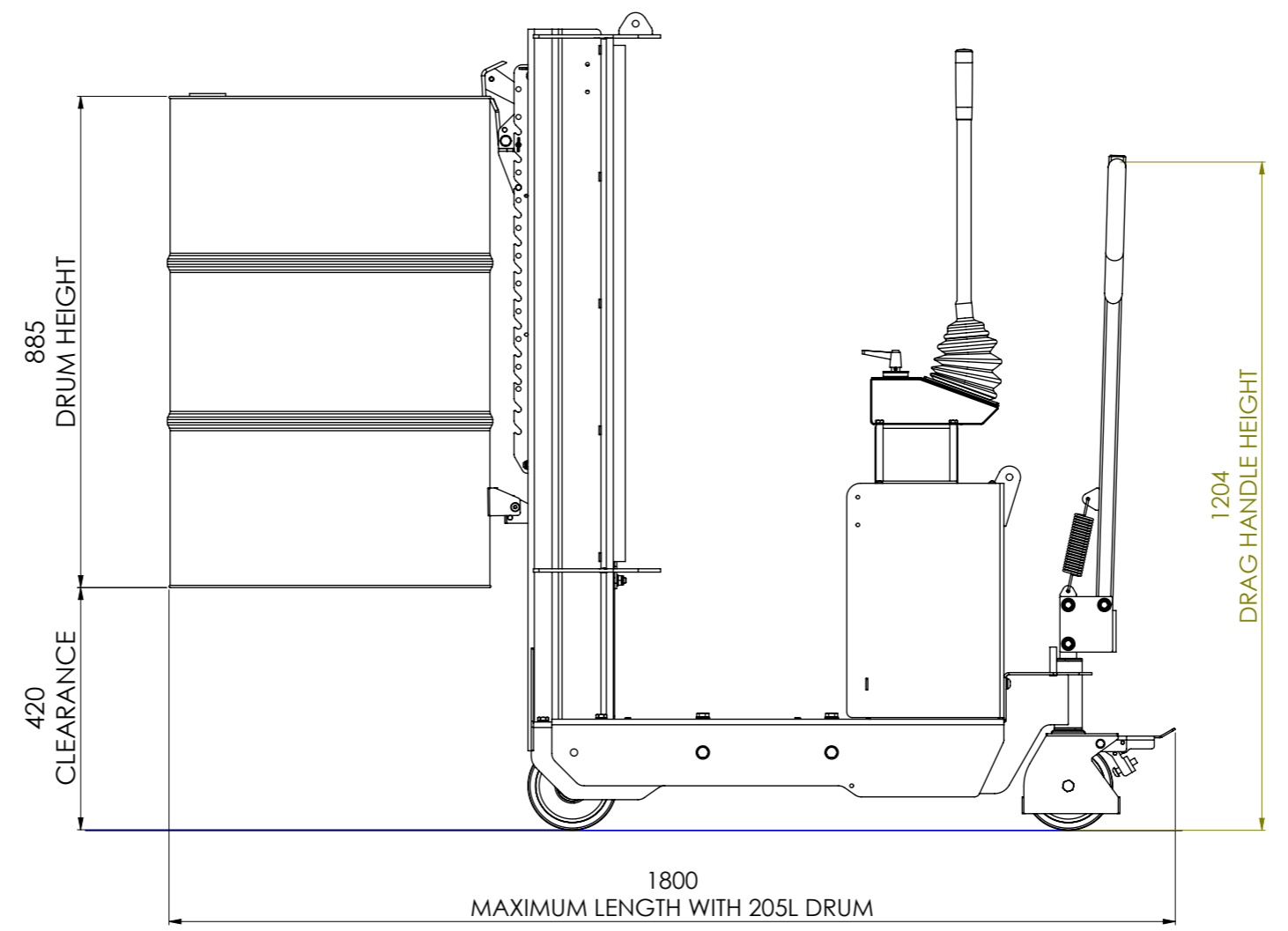
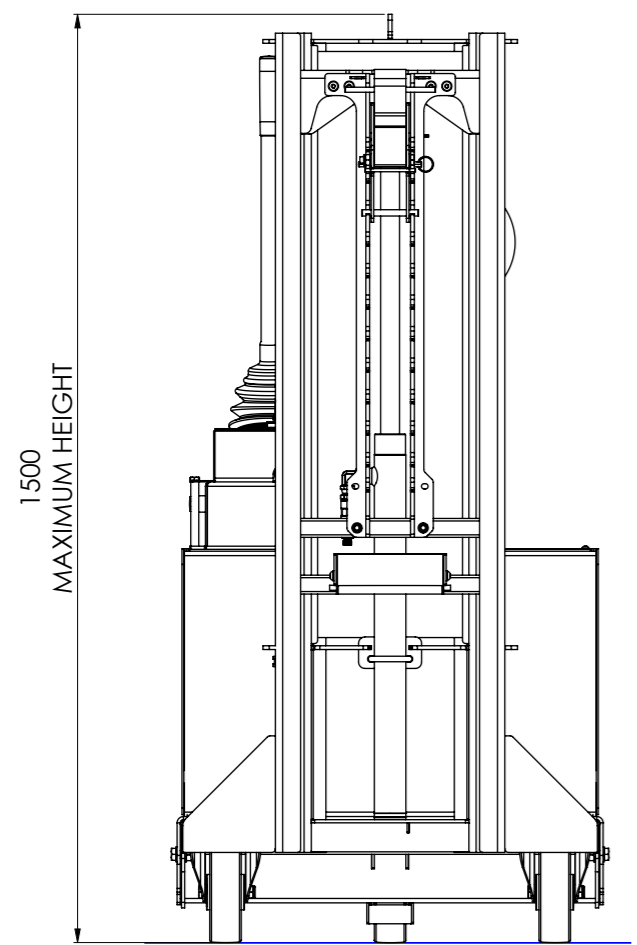
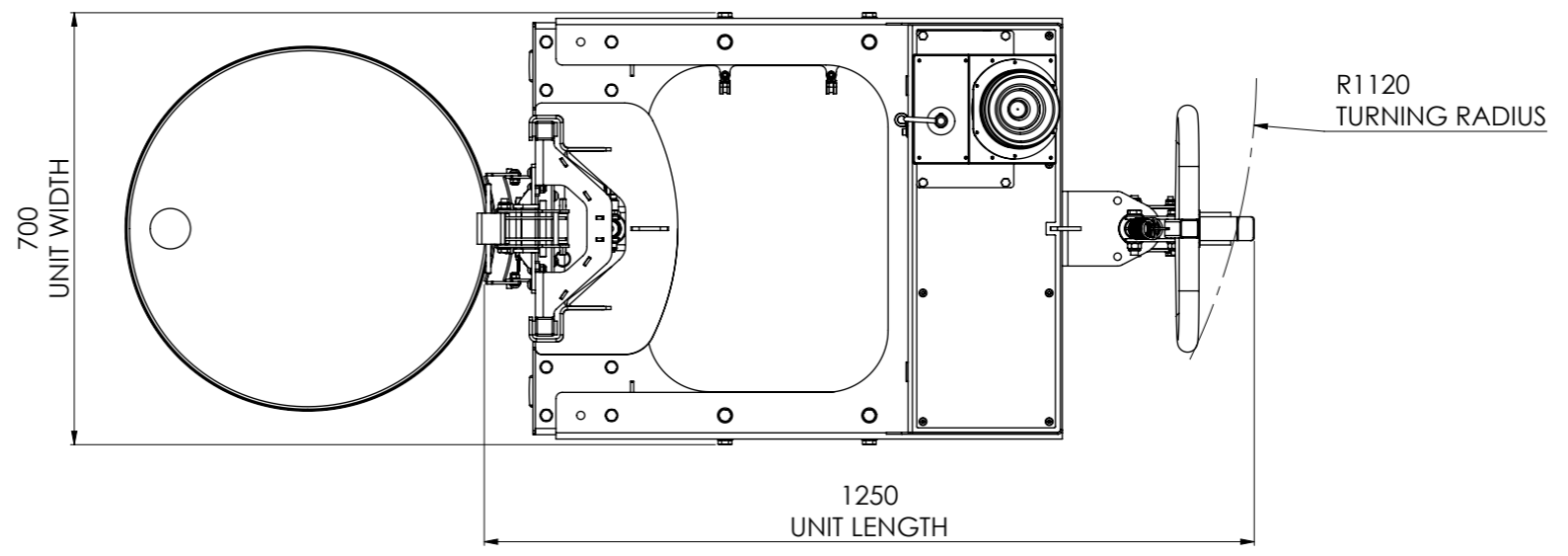
A A

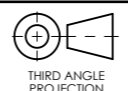



 THIRD ANGLE PROJECTION	ALL DIMENSIONS IN mm U.O.S	DESCRIPTION: DTP08-250KG-R500-SS, DEPALLETISER, 500MM STROKE, 250KG SWL	SHEET NO: 2 OF 4
	DO NOT SCALE		DRAWN BY: JC
 BESPOKE HANDLING EQUIPMENT LTD LEEDSTOWN, CORNWALL, TR27 4DS TEL: +44 1736 85 10 50 FAX: +44 1736 85 10 23 E-MAIL: SALES@STS-TROLLEYS.CO.UK WWW: HTTPS://WWW.STS-TROLLEYS.CO.UK		CUSTOMER APPROVAL: NAME: SIGNATURE: DATE:	SHEET SIZE: A3
			PART NUMBER: 022509

THIS DOCUMENT AND ALL THE INFORMATION CONTAINED HEREIN ARE CONFIDENTIAL AND EXCLUSIVE PROPERTY OF STS BESPOKE HANDLING EQUIPMENT AND MAY NOT BE REPRODUCED, USED, DISCLOSED OR MADE PUBLIC IN ANY MANNER PRIOR TO EXPRESS WRITTEN AUTHORIZATION BY STS BESPOKE HANDLING EQUIPMENT.
THIS DOCUMENT IS ACCEPTED PURSUANT TO AGREEMENT TO THE FOREGOING, AND MUST BE RETURNED OR DESTROYED UPON DEMAND.
MANUFACTURER AGREES THAT ARTICLES MADE IN ACCORDANCE WITH THIS DOCUMENT SHALL BE CONSIDERED STS BESPOKE HANDLING EQUIPMENT'S DESIGN AND THAT IDENTICAL ARTICLES OR PARTS THEREOF SHALL NOT BE MANUFACTURED FOR THE USE OR SALE BY THE MANUFACTURER OR ANY OTHER PERSON OR ENTITY WITHOUT PRIOR EXPRESS WRITTEN AUTHORIZATION BY STS BESPOKE HANDLING EQUIPMENT.

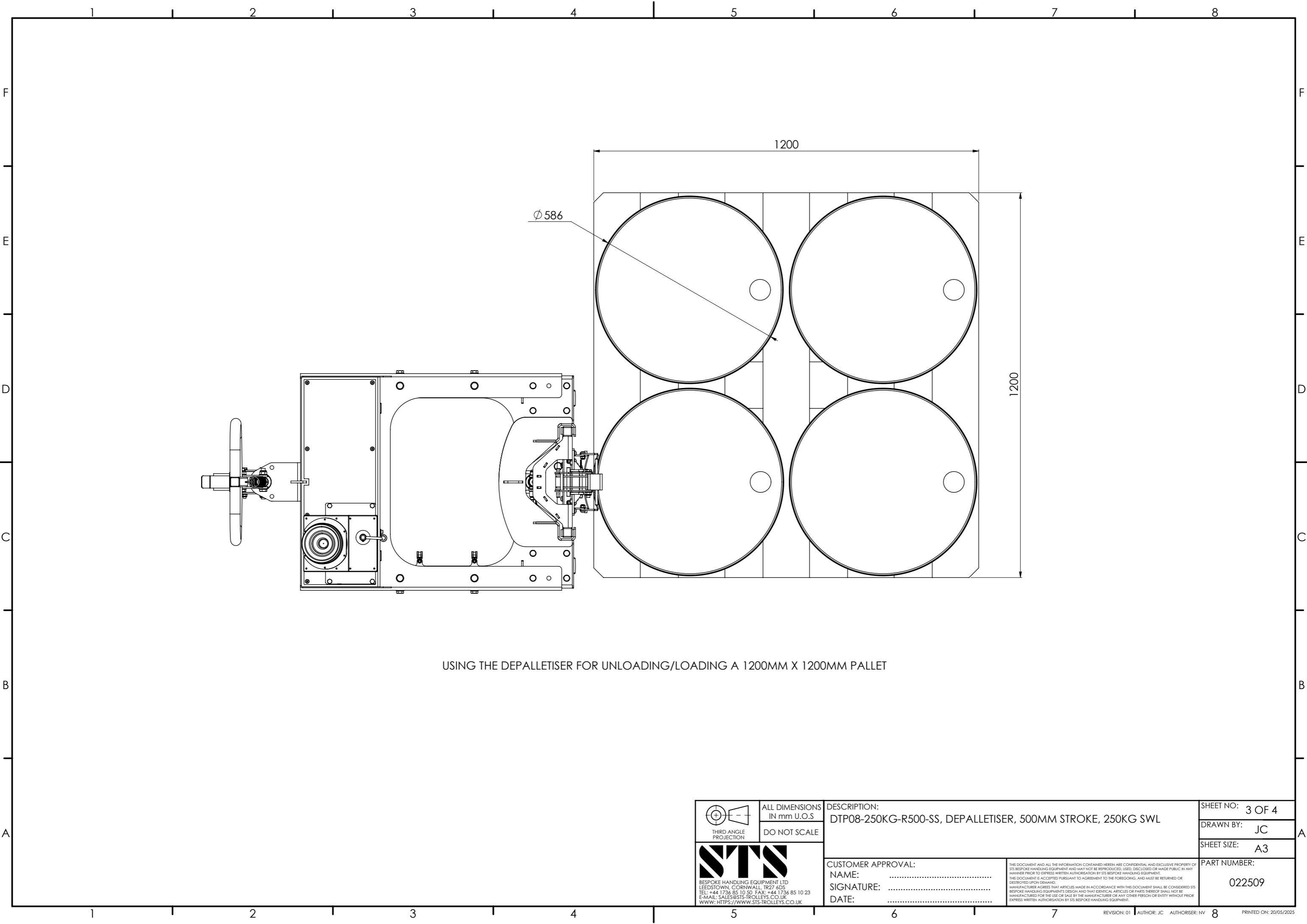
1 2 3 4 5 6 7 8

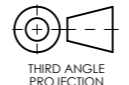

USING THE DEPALLETISER FOR UNLOADING/LOADING A 1200MM X 1200MM PALLET

 THIRD ANGLE PROJECTION	ALL DIMENSIONS IN mm U.O.S. DO NOT SCALE	DESCRIPTION: DTP08-250KG-R500-SS, DEPALLETISER, 500MM STROKE, 250KG SWL	SHEET NO: 3 OF 4 DRAWN BY: JC SHEET SIZE: A3
	 BESPOKE HANDLING EQUIPMENT LTD LEEDSTOWN, CORNWALL, TR27 6DS TEL: +44 1736 85 10 50 FAX: +44 1736 85 10 23 E-MAIL: SALES@STN-TROLLEYS.CO.UK WWW: HTTPS://WWW.STN-TROLLEYS.CO.UK	CUSTOMER APPROVAL: NAME: SIGNATURE: DATE:	<small>THIS DOCUMENT AND ALL THE INFORMATION CONTAINED HEREIN ARE CONFIDENTIAL AND EXCLUSIVE PROPERTY OF STN BESPOKE HANDLING EQUIPMENT AND MAY NOT BE REPRODUCED, USED, DISCLOSED OR MADE PUBLIC IN ANY MANNER PRIOR TO EXPRESS WRITTEN AUTHORIZATION BY STN BESPOKE HANDLING EQUIPMENT. THIS DOCUMENT IS ACCEPTED PURSUANT TO AGREEMENT TO THE FOREGOING, AND MUST BE RETURNED OR DESTROYED UPON DEMAND. MANUFACTURER AGREES THAT ARTICLES MADE IN ACCORDANCE WITH THIS DOCUMENT SHALL BE CONSIDERED STN BESPOKE HANDLING EQUIPMENT'S DESIGN AND THAT IDENTICAL ARTICLES OR PARTS THEREOF SHALL NOT BE MANUFACTURED FOR THE USE OR SALE BY THE MANUFACTURER OR ANY OTHER PERSON OR ENTITY WITHOUT PRIOR EXPRESS WRITTEN AUTHORIZATION BY STN BESPOKE HANDLING EQUIPMENT.</small>