

DRU04-SS-EX

SWL - 350kg

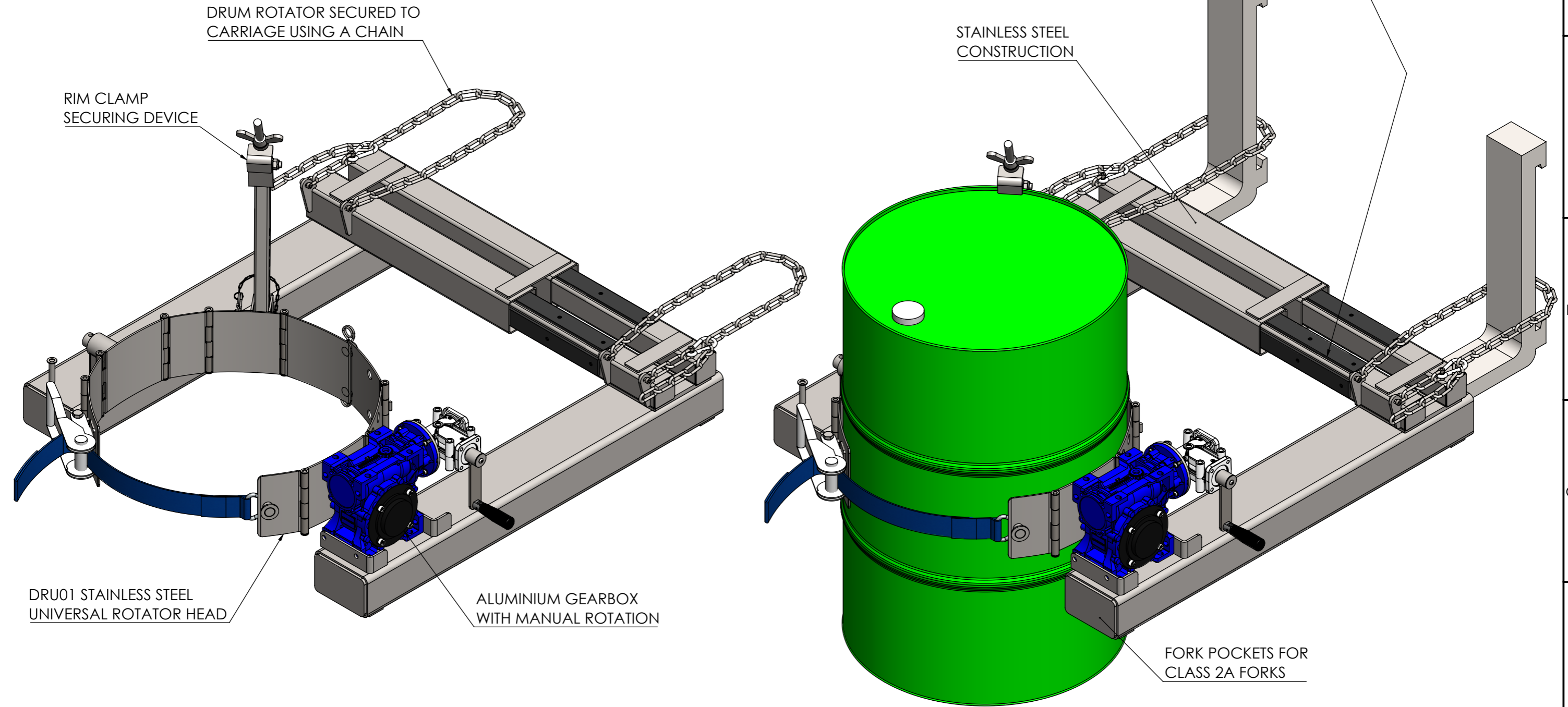

NOTE: THE END USER MUST ENSURE THAT THE FORKLIFT/STACKER TRUCK IS EARTHED

Ex II 2 G D

Ex h IIB T4 Gb

Ex h IIIB T135°C Db

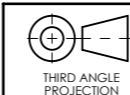

ALL DIMENSIONS
IN mm U.O.S
DO NOT SCALE



BESPOKE HANDLING EQUIPMENT LTD
LEEDSTOWN, CORNWALL, TR27 6DS
TEL: +44 1736 85 10 50 FAX: +44 1736 85 10 23
E-MAIL: SALES@STS-TROLLEYS.CO.UK
WWW: HTTPS://WWW.STS-TROLLEYS.CO.UK

DESCRIPTION:
DRUM ROTATOR, DRU04-SS-EX, AISI 304, 350KG SWL

CUSTOMER APPROVAL:
NAME:
SIGNATURE:
DATE:

THIS DOCUMENT AND ALL THE INFORMATION CONTAINED HEREIN ARE CONFIDENTIAL AND EXCLUSIVE PROPERTY OF STS BESPOKE HANDLING EQUIPMENT AND MAY NOT BE REPRODUCED, USED, DISCLOSED OR MADE PUBLIC IN ANY MANNER PRIOR TO EXPRESS WRITTEN AUTHORIZATION BY STS BESPOKE HANDLING EQUIPMENT.
THIS DOCUMENT IS ACCEPTED PURSUANT TO AGREEMENT TO THE FOREGOING, AND MUST BE RETURNED OR DESTROYED UPON DEMAND.
MANUFACTURER AGREES THAT ARTICLES MADE IN ACCORDANCE WITH THIS DOCUMENT SHALL BE CONSIDERED STS BESPOKE HANDLING EQUIPMENT'S DESIGN AND THAT IDENTICAL ARTICLES OR PARTS THEREOF SHALL NOT BE MANUFACTURED FOR THE USE OR SALE BY THE MANUFACTURER OR ANY OTHER PERSON OR ENTITY WITHOUT PRIOR EXPRESS WRITTEN AUTHORIZATION BY STS BESPOKE HANDLING EQUIPMENT.

SHEET NO: 1 OF 6
DRAWN BY: JC
SHEET SIZE: A3
PART NUMBER: 023227

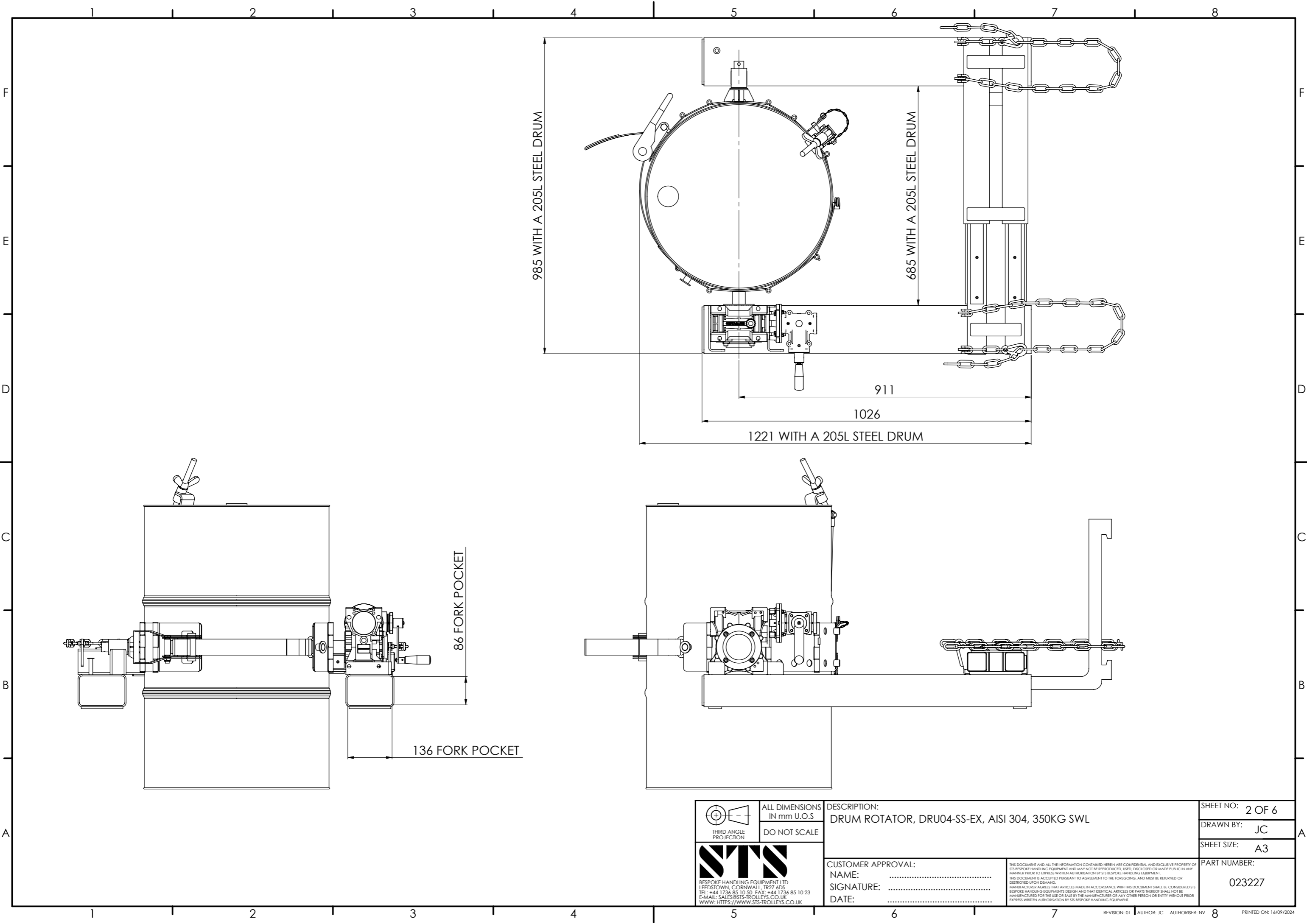

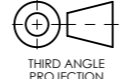
 ALL DIMENSIONS
 IN mm U.O.S
 DO NOT SCALE



 BESPOKE HANDLING EQUIPMENT LTD
 LEEDSTOWN, CORNWALL, TR27 6DS
 TEL: +44 1736 85 10 50 FAX: +44 1736 85 10 23
 E-MAIL: SALES@STIS-TROLLEYS.CO.UK
 WWW: HTTPS://WWW.STIS-TROLLEYS.CO.UK

DESCRIPTION:
 DRUM ROTATOR, DRU04-SS-EX, AISI 304, 350KG SWL

CUSTOMER APPROVAL:
 NAME:
 SIGNATURE:
 DATE:

THIS DOCUMENT AND ALL THE INFORMATION CONTAINED HEREIN ARE CONFIDENTIAL AND EXCLUSIVE PROPERTY OF STS BESPOKE HANDLING EQUIPMENT AND MAY NOT BE REPRODUCED, USED, DISCLOSED OR MADE PUBLIC IN ANY MANNER PRIOR TO EXPRESS WRITTEN AUTHORIZATION BY STS BESPOKE HANDLING EQUIPMENT.
 THIS DOCUMENT IS ACCEPTED PURSUANT TO AGREEMENT TO THE FOREGOING, AND MUST BE RETURNED OR DESTROYED UPON DEMAND.
 MANUFACTURER AGREES THAT ARTICLES MADE IN ACCORDANCE WITH THIS DOCUMENT SHALL BE CONSIDERED STS BESPOKE HANDLING EQUIPMENT'S DESIGN AND THAT IDENTICAL ARTICLES OR PARTS THEREOF SHALL NOT BE MANUFACTURED FOR THE USE OR SALE BY THE MANUFACTURER OR ANY OTHER PERSON OR ENTITY WITHOUT PRIOR EXPRESS WRITTEN AUTHORIZATION BY STS BESPOKE HANDLING EQUIPMENT.

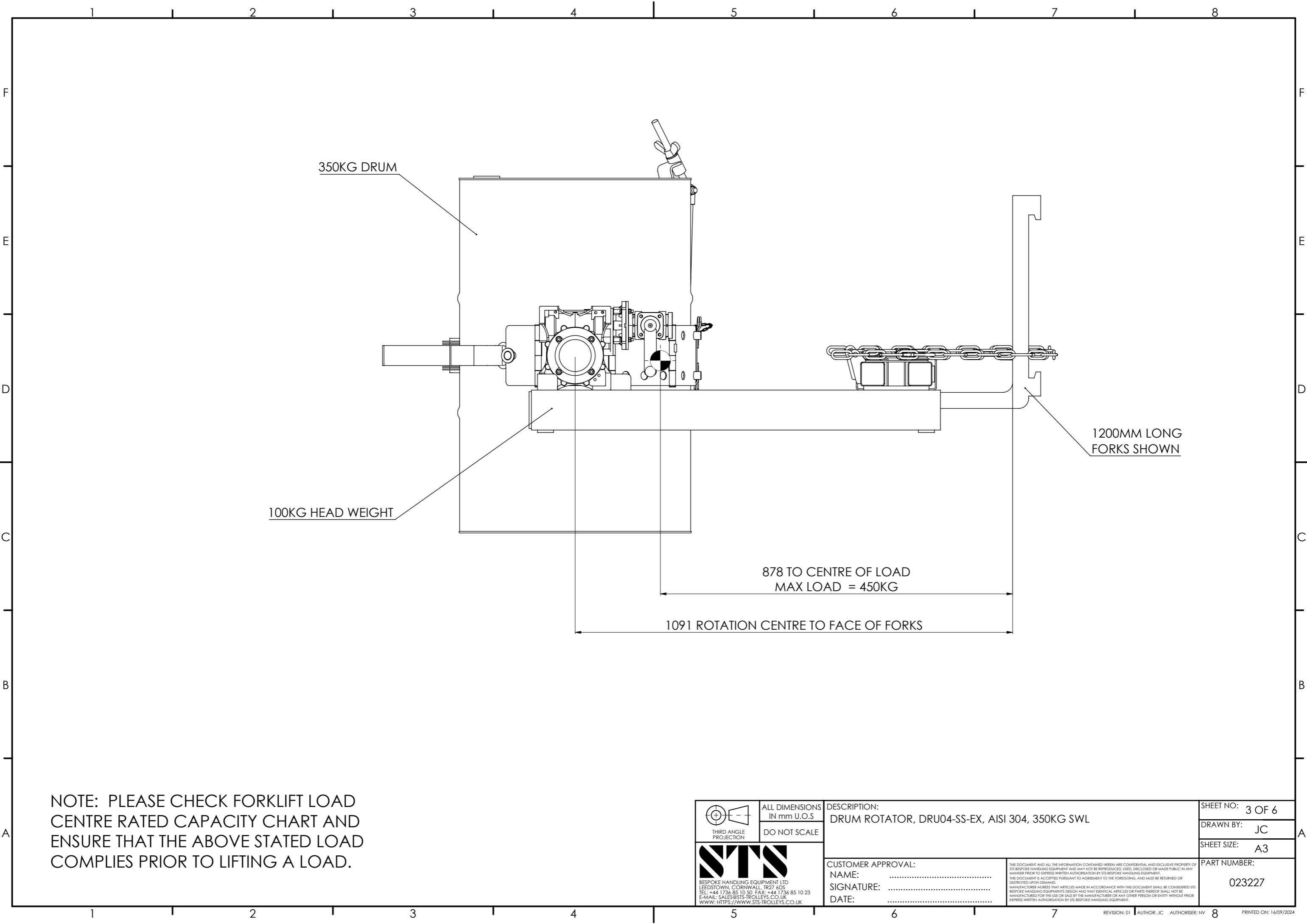
SHEET NO: 2 OF 6
 DRAWN BY: JC
 SHEET SIZE: A3
 PART NUMBER:
 023227



350KG DRUM

100KG HEAD WEIGHT

1200MM LONG
FORKS SHOWN

878 TO CENTRE OF LOAD
MAX LOAD = 450KG

1091 ROTATION CENTRE TO FACE OF FORKS

NOTE: PLEASE CHECK FORKLIFT LOAD CENTRE RATED CAPACITY CHART AND ENSURE THAT THE ABOVE STATED LOAD COMPLIES PRIOR TO LIFTING A LOAD.

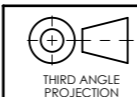

ALL DIMENSIONS
IN mm U.O.S
DO NOT SCALE

DESCRIPTION:
DRUM ROTATOR, DRU04-SS-EX, AISI 304, 350KG SWL

SHEET NO: 3 OF 6

DRAWN BY: JC

SHEET SIZE: A3



BESPOKE HANDLING EQUIPMENT LTD
LEEDSTOWN, CORNWALL, TR27 6DS
TEL: +44 1736 85 10 50 FAX: +44 1736 85 10 23
E-MAIL: SALES@STN-TROLLEYS.CO.UK
WWW: HTTPS://WWW.STN-TROLLEYS.CO.UK



CUSTOMER APPROVAL:
NAME:
SIGNATURE:
DATE:

THIS DOCUMENT AND ALL THE INFORMATION CONTAINED HEREIN ARE CONFIDENTIAL AND EXCLUSIVE PROPERTY OF STN BESPOKE HANDLING EQUIPMENT AND MAY NOT BE REPRODUCED, USED, DISCLOSED OR MADE PUBLIC IN ANY MANNER PRIOR TO EXPRESS WRITTEN AUTHORIZATION BY STN BESPOKE HANDLING EQUIPMENT.
THIS DOCUMENT IS ACCEPTED PURSUANT TO AGREEMENT TO THE FOREGOING, AND MUST BE RETURNED OR DESTROYED UPON DEMAND.
MANUFACTURER AGREES THAT ARTICLES MADE IN ACCORDANCE WITH THIS DOCUMENT SHALL BE CONSIDERED STN BESPOKE HANDLING EQUIPMENT'S DESIGN AND THAT IDENTICAL ARTICLES OR PARTS THEREOF SHALL NOT BE MANUFACTURED FOR THE USE OR SALE BY THE MANUFACTURER OR ANY OTHER PERSON OR ENTITY WITHOUT PRIOR EXPRESS WRITTEN AUTHORIZATION BY STN BESPOKE HANDLING EQUIPMENT.

PART NUMBER:
023227

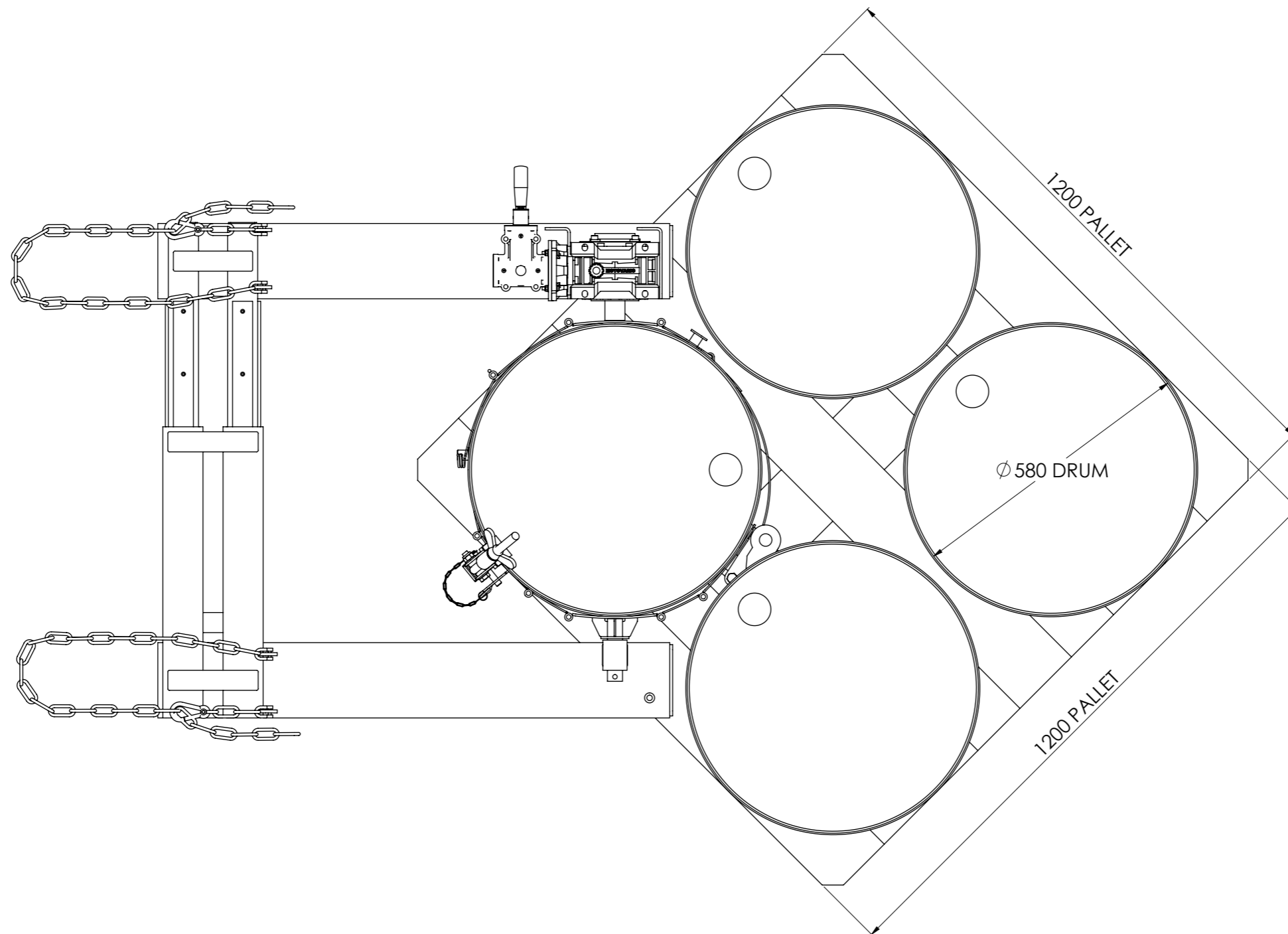
DEPALLETISING 4 X 205L DRUMS FROM A 1200MM X 1200MM PALLET USING THE STS DRUM ROTATOR

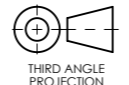

 THIRD ANGLE PROJECTION	ALL DIMENSIONS IN mm U.O.S. DO NOT SCALE	DESCRIPTION: DRUM ROTATOR, DRU04-SS-EX, AISI 304, 350KG SWL	SHEET NO: 4 OF 6
	 BESPOKE HANDLING EQUIPMENT LTD LEEDSTOWN, CORNWALL, TR27 6DS TEL: +44 1736 85 10 50 FAX: +44 1736 85 10 23 E-MAIL: SALES@STS-TROLLEYS.CO.UK WWW: HTTPS://WWW.STS-TROLLEYS.CO.UK		CUSTOMER APPROVAL: NAME: SIGNATURE: DATE:
		<small>THIS DOCUMENT AND ALL THE INFORMATION CONTAINED HEREIN ARE CONFIDENTIAL AND EXCLUSIVE PROPERTY OF STS BESPOKE HANDLING EQUIPMENT AND MAY NOT BE REPRODUCED, USED, DISCLOSED OR MADE PUBLIC IN ANY MANNER PRIOR TO EXPRESS WRITTEN AUTHORIZATION BY STS BESPOKE HANDLING EQUIPMENT. THIS DOCUMENT IS ACCEPTED PURSUANT TO AGREEMENT TO THE FOREGOING, AND MUST BE RETURNED OR DESTROYED UPON DEMAND. MANUFACTURER AGREES THAT ARTICLES MADE IN ACCORDANCE WITH THIS DOCUMENT SHALL BE CONSIDERED STS BESPOKE HANDLING EQUIPMENT'S DESIGN AND THAT IDENTICAL ARTICLES OR PARTS THEREOF SHALL NOT BE MANUFACTURED FOR THE USE OR SALE BY THE MANUFACTURER OR ANY OTHER PERSON OR ENTITY WITHOUT PRIOR EXPRESS WRITTEN AUTHORIZATION BY STS BESPOKE HANDLING EQUIPMENT.</small>	PART NUMBER: 023227

DEPALLETISING 2 X 205L DRUMS FROM A 1200MM X 800MM EURO PALLET USING THE STS DRUM ROTATOR

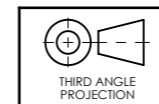
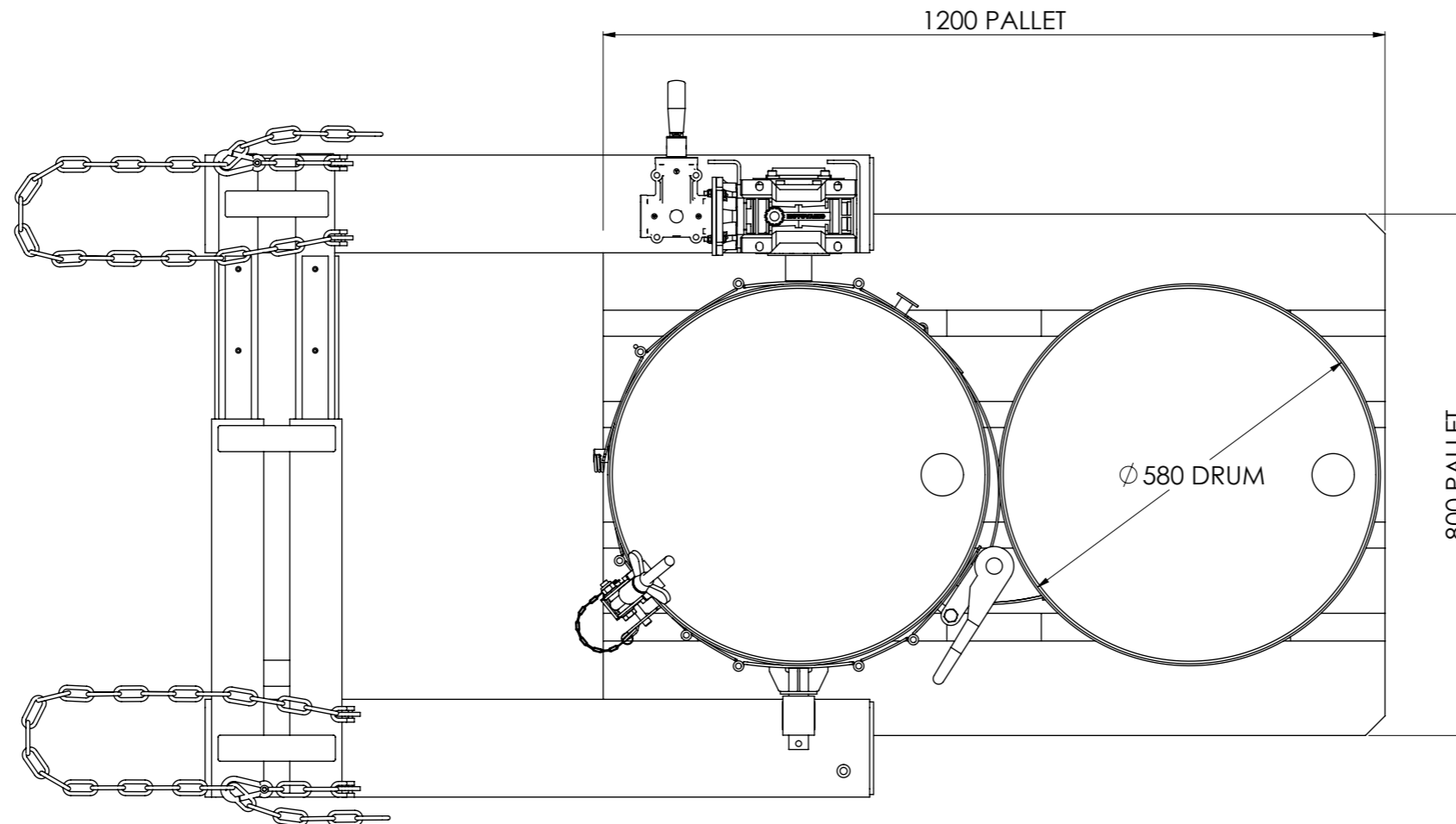

ALL DIMENSIONS
IN mm U.O.S
DO NOT SCALE

DESCRIPTION:
DRUM ROTATOR, DRU04-SS-EX, AISI 304, 350KG SWL

SHEET NO: 5 OF 6

DRAWN BY: JC

SHEET SIZE: A3



CUSTOMER APPROVAL:
NAME:
SIGNATURE:
DATE:

THIS DOCUMENT AND ALL THE INFORMATION CONTAINED HEREIN ARE CONFIDENTIAL AND EXCLUSIVE PROPERTY OF STS BESPOKE HANDLING EQUIPMENT AND MAY NOT BE REPRODUCED, USED, DISCLOSED OR MADE PUBLIC IN ANY MANNER PRIOR TO EXPRESS WRITTEN AUTHORIZATION BY STS BESPOKE HANDLING EQUIPMENT.
THIS DOCUMENT IS ACCEPTED PURSUANT TO AGREEMENT TO THE FOREGOING, AND MUST BE RETURNED OR DESTROYED UPON DEMAND.
MANUFACTURER AGREES THAT ARTICLES MADE IN ACCORDANCE WITH THIS DOCUMENT SHALL BE CONSIDERED STS BESPOKE HANDLING EQUIPMENT'S DESIGN AND THAT IDENTICAL ARTICLES OR PARTS THEREOF SHALL NOT BE MANUFACTURED FOR THE USE OR SALE BY THE MANUFACTURER OR ANY OTHER PERSON OR ENTITY WITHOUT PRIOR EXPRESS WRITTEN AUTHORIZATION BY STS BESPOKE HANDLING EQUIPMENT.

PART NUMBER:
023227