

**DTP04-R500-1250-SS**

**SWL - 350kg**

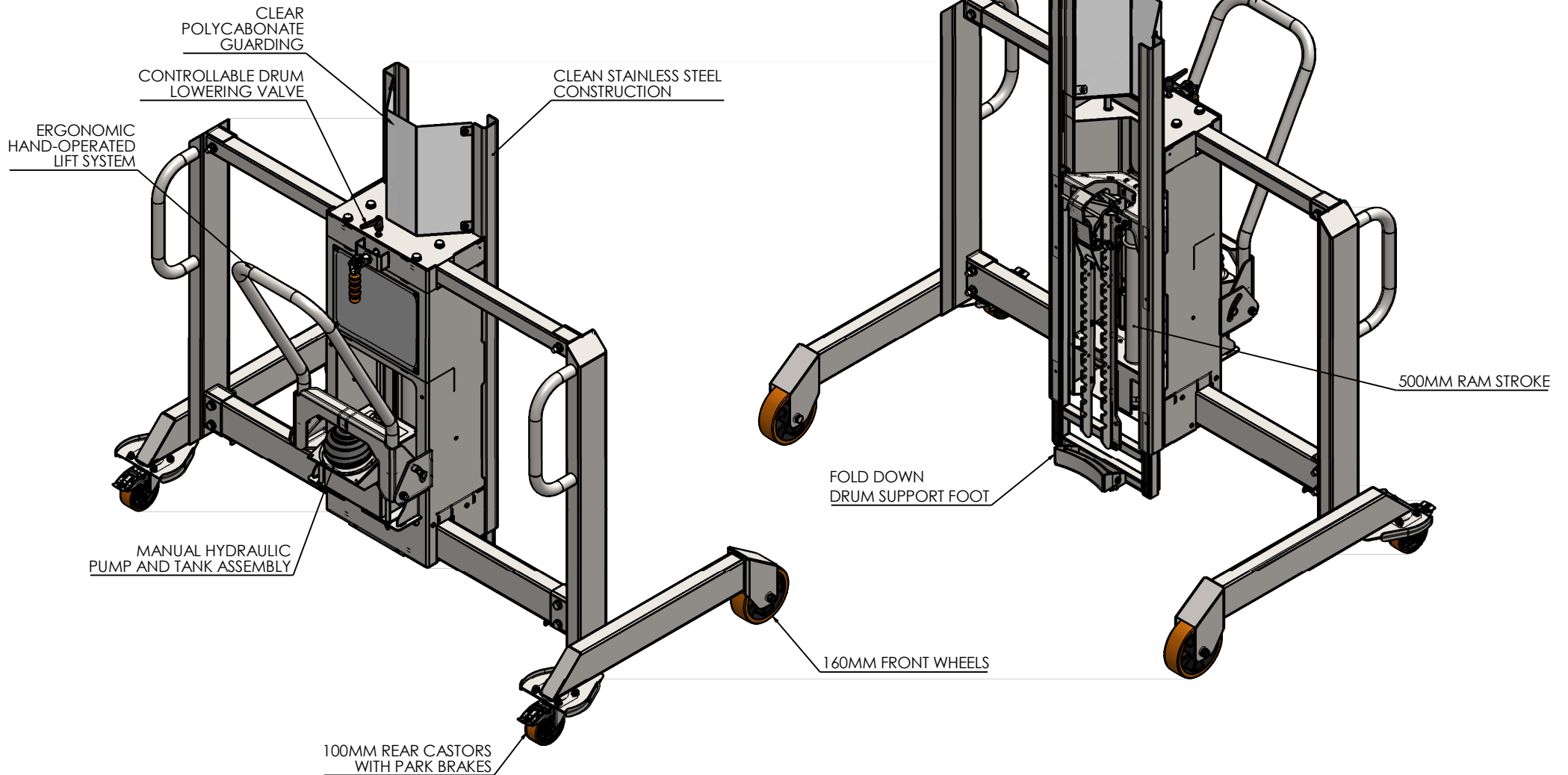

Drum Range: 50L - 220L  
 Minimum Lift Clearance: 420mm

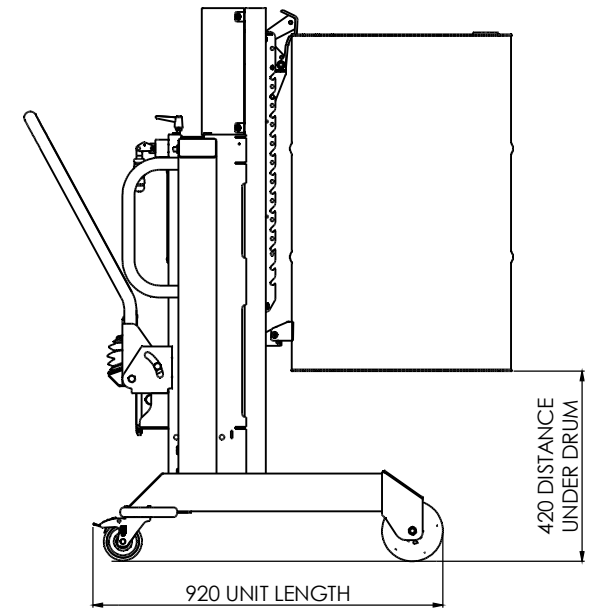
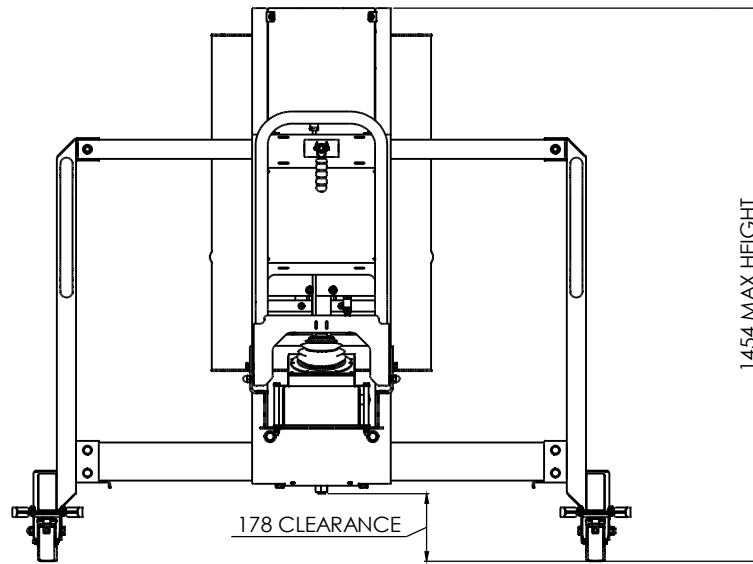
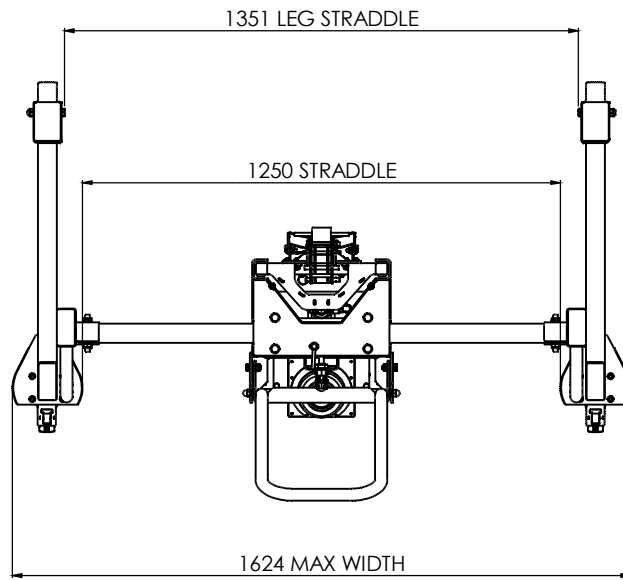

<p>THIRD ANGLE PROJECTION</p>	<p>ALL DIMENSIONS IN mm U.O.S.</p> <p>DO NOT SCALE</p>	<p>DESCRIPTION:                  DEPALLETISER ASSEMBLY, DTP04-R500-1250-SS, STAINLESS STEEL, 350KG SWL</p>	<p>SHEET NO: 1 OF 4</p>
	<p>RESPONSE HANDLING EQUIPMENT LTD                  LEEDSTOWN, CORNWALL TR27 6DS                  TEL: +44 1736 85 10 55 FAX: +44 1736 85 10 23                  E-MAIL: SALES@STS-TROLLEYS.CO.UK                  WWW: HTTPS://WWW.STS-TROLLEYS.CO.UK</p>	<p>CUSTOMER APPROVAL:                  NAME: .....                  SIGNATURE: .....                  DATE: .....</p>	<p>DRAWN BY: FD</p> <p>SHEET SIZE: A3</p> <p>PART NUMBER:                  023108</p>

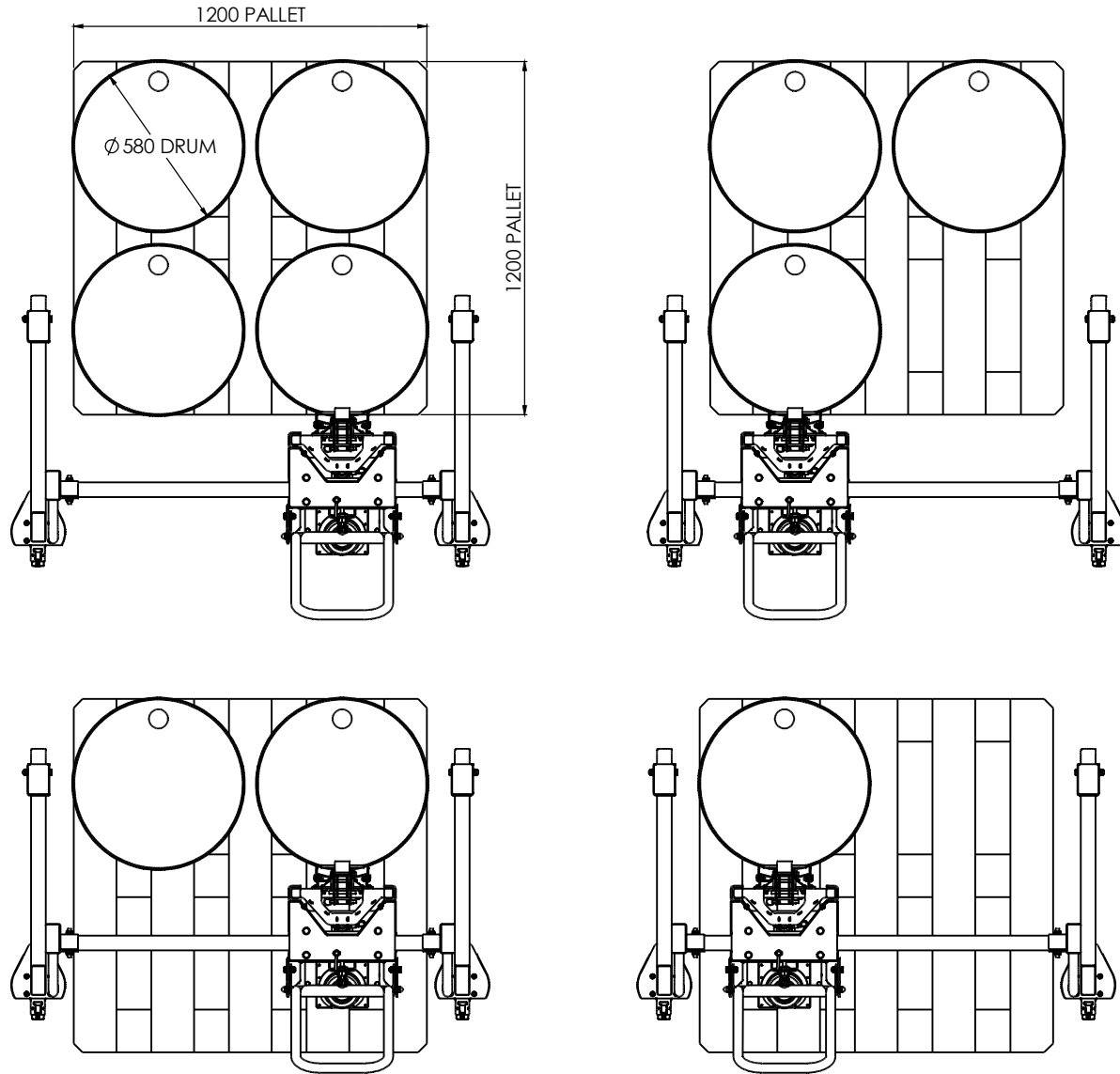

 THIRD ANGLE PROJECTION	ALL DIMENSIONS IN mm U.O.S	DESCRIPTION: DEPALLETERISER ASSEMBLY, DTP04-R500-1250-SS, STAINLESS STEEL, 350KG SWL	SHEET NO: 2 OF 4
	DO NOT SCALE		DRAWN BY: FD
 RESPONCE HANDLING EQUIPMENT LTD LEEDSTOWN, CORNWALL TR27 6DS TEL: +44 1736 85 10 55 FAX: +44 1736 85 10 23 E-MAIL: SALES@STS-TROLLEYS.CO.UK WWW: HTTPS://WWW.STS-TROLLEYS.CO.UK	CUSTOMER APPROVAL:		SHEET SIZE: A3
	NAME: .....		PART NUMBER: 023108
	SIGNATURE: .....		
DATE: .....		<small>THIS DOCUMENT AND ALL THE INFORMATION CONTAINED HEREIN ARE CONFIDENTIAL AND EXCLUSIVE PROPERTY OF STS RESPONCE HANDLING EQUIPMENT AND MAY NOT BE REPRODUCED, USED, DISCLOSED OR MADE PUBLIC IN ANY MANNER PRIOR TO WRITTEN AUTHORIZATION BY STS RESPONCE HANDLING EQUIPMENT.          THIS DOCUMENT IS ACCEPTED PURSUANT TO AGREEMENT TO THE FOREGOING, AND MUST BE RETURNED OR DESTROYED UPON DEMAND.          MANUFACTURER AGREES THAT ARTICLES MADE IN ACCORDANCE WITH THIS DOCUMENT SHALL BE CONSIDERED STS RESPONCE HANDLING EQUIPMENT'S DESIGN AND THAT PERIODICAL ARTICLES OR PARTS THEREOF SHALL NOT BE MANUFACTURED FOR THE USE OR SALE BY THE MANUFACTURER OR ANY OTHER PERSON OR ENTITY WITHOUT PRIOR WRITTEN AUTHORIZATION BY STS RESPONCE HANDLING EQUIPMENT.</small>	

DE-PALLETISING 4 X 205L DRUMS FROM  
A 1200MM X 1200MM PALLET USING THE  
STS DTP04 SIDE SHIFT DE-PALLETISER



 THIRD ANGLE PROJECTION	ALL DIMENSIONS IN mm U.O.S DO NOT SCALE	CUSTOMER APPROVAL: NAME: ..... SIGNATURE: ..... DATE:	CATEGORY: ASSEMBLY MATERIAL SPEC: FINISH: N/A DESCRIPTION: DEPALLETISER ASSEMBLY, DTP04-R500-1250-SS, STAINLESS STEEL, 350KG SWL	SHEET NO: 3 OF 4 EST MASS: 127.71kg SHEET SIZE: A3 PART NUMBER: 023108	DRAWN BY: FD CHECKED BY: JS DATE CHK: 16/02/2024 REVISION: A	
		<small>           THE DOCUMENT AND ALL THE INFORMATION CONTAINED HEREIN ARE CONFIDENTIAL AND BELONG TO THE PROPERTY OF STS SPECIAL HANDLING EQUIPMENT LTD. UNLESS OTHERWISE STATED. NO PART OF THIS DOCUMENT OR ANY INFORMATION CONTAINED HEREIN IS TO BE REPRODUCED OR TRANSMITTED IN ANY FORM OR BY ANY MEANS, ELECTRONIC OR MECHANICAL, INCLUDING PHOTOCOPYING, RECORDING, OR BY ANY INFORMATION STORAGE AND RETRIEVAL SYSTEM, WITHOUT THE WRITTEN PERMISSION OF STS SPECIAL HANDLING EQUIPMENT LTD.         </small>	<small>           THIS DOCUMENT IS ACCEPTED PURSUANT TO AGREEMENT TO THE FOREGOING, AND MUST BE RETURNED OR DESTROYED UPON REQUEST.         </small>	<small>           THESE ARTICLES MADE IN ACCORDANCE WITH THIS DOCUMENT SHALL BE CONSIDERED AS SPECIAL HANDLING EQUIPMENT DESIGN AND THAT IDENTICAL ARTICLES OR PARTS THEREOF SHALL NOT BE MANUFACTURED FOR THE USE OR SALE BY THE MANUFACTURER OR ANY OTHER PERSON OR ENTITY WITHOUT PRIOR EXPRESS WRITTEN AUTHORISATION BY STS SPECIAL HANDLING EQUIPMENT LTD.         </small>	<small>           REVISION: 01 AUTHOR: JC. AUTHORISED BY: NV         </small>	<small>           PRINTED ON: 16/02/2024         </small>