

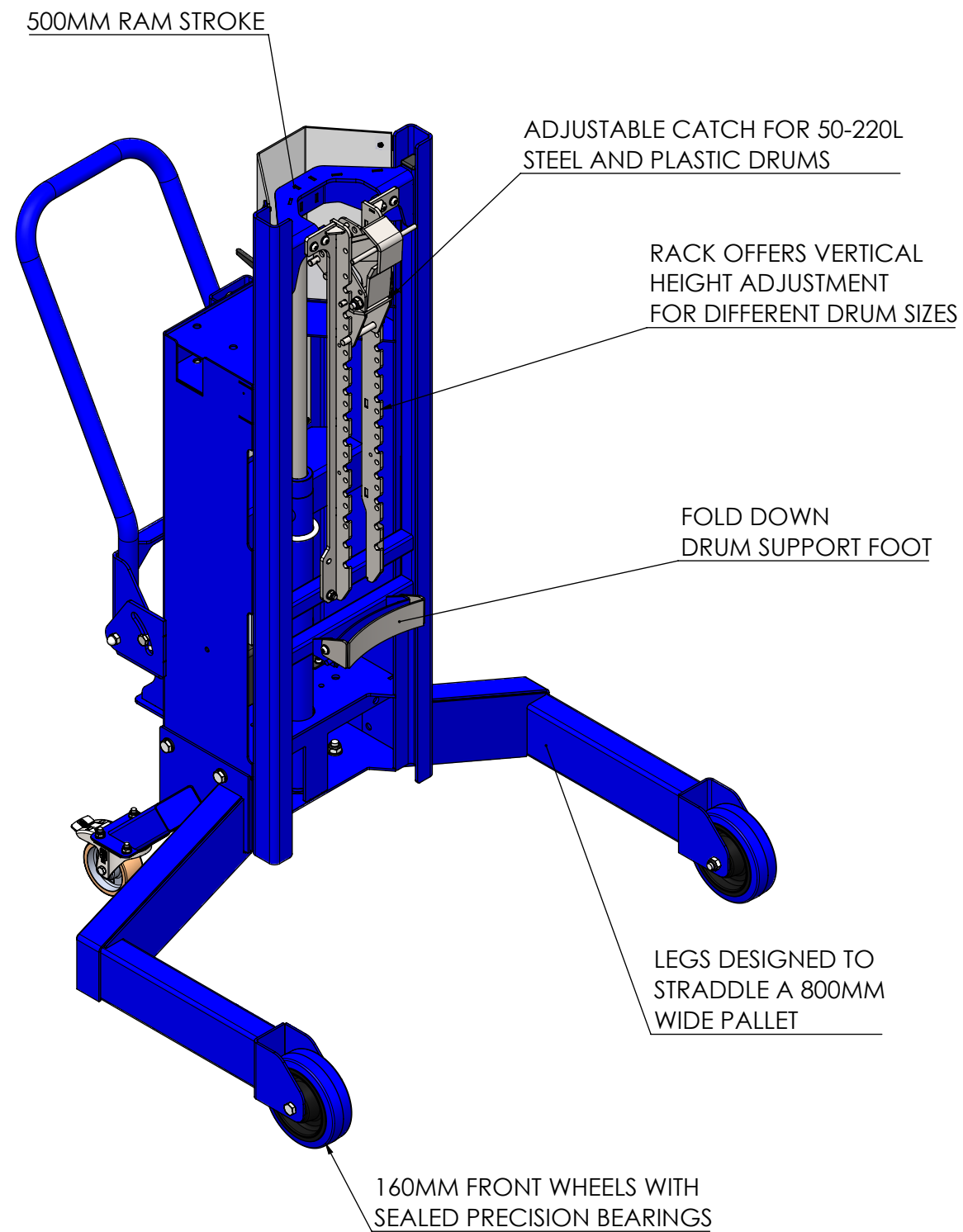

# DTP03-R500

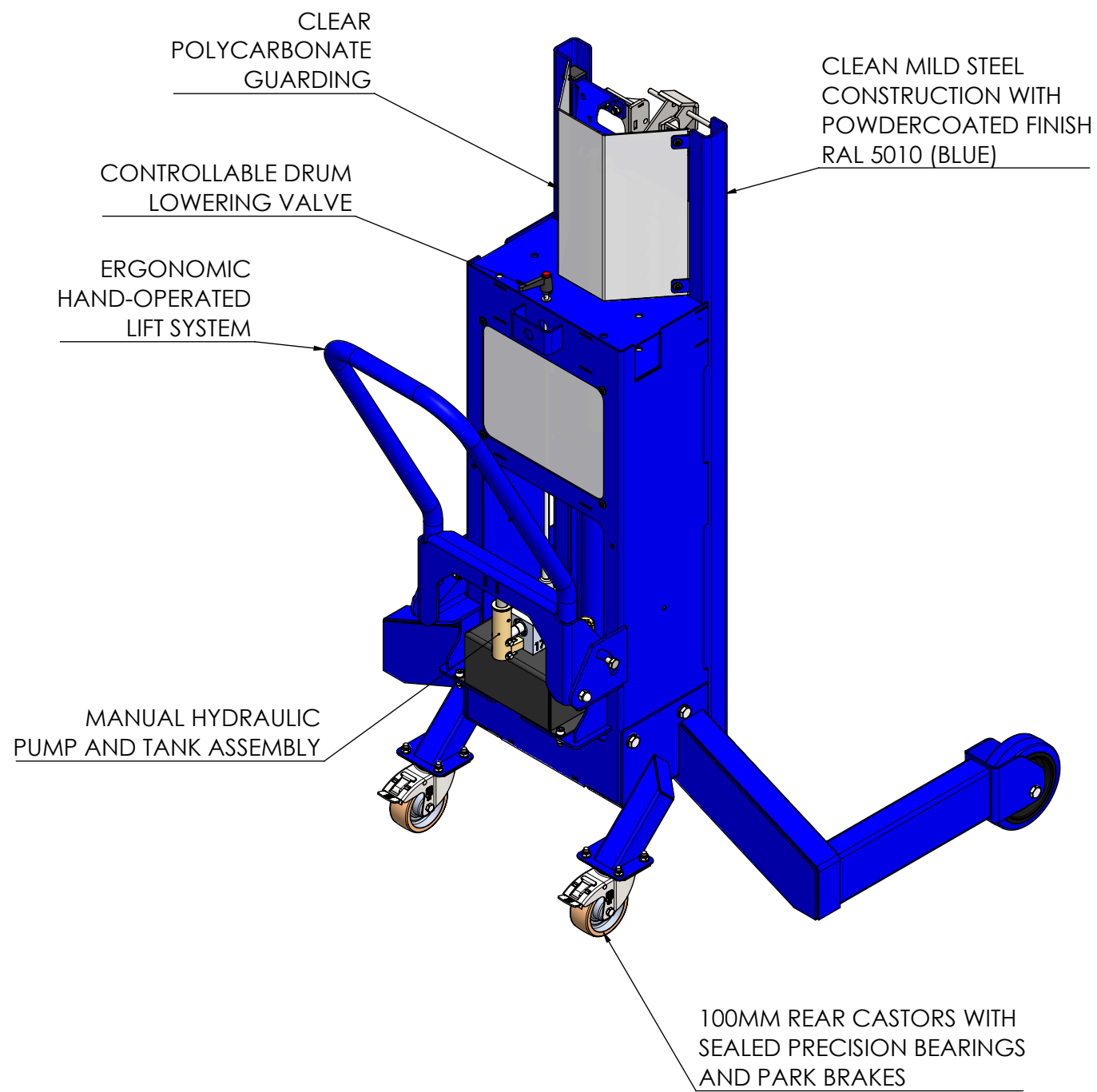

**SWL - 350kg**

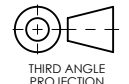

Drum Range: 50L - 220L  
Minimum Lift Clearance: 420mm

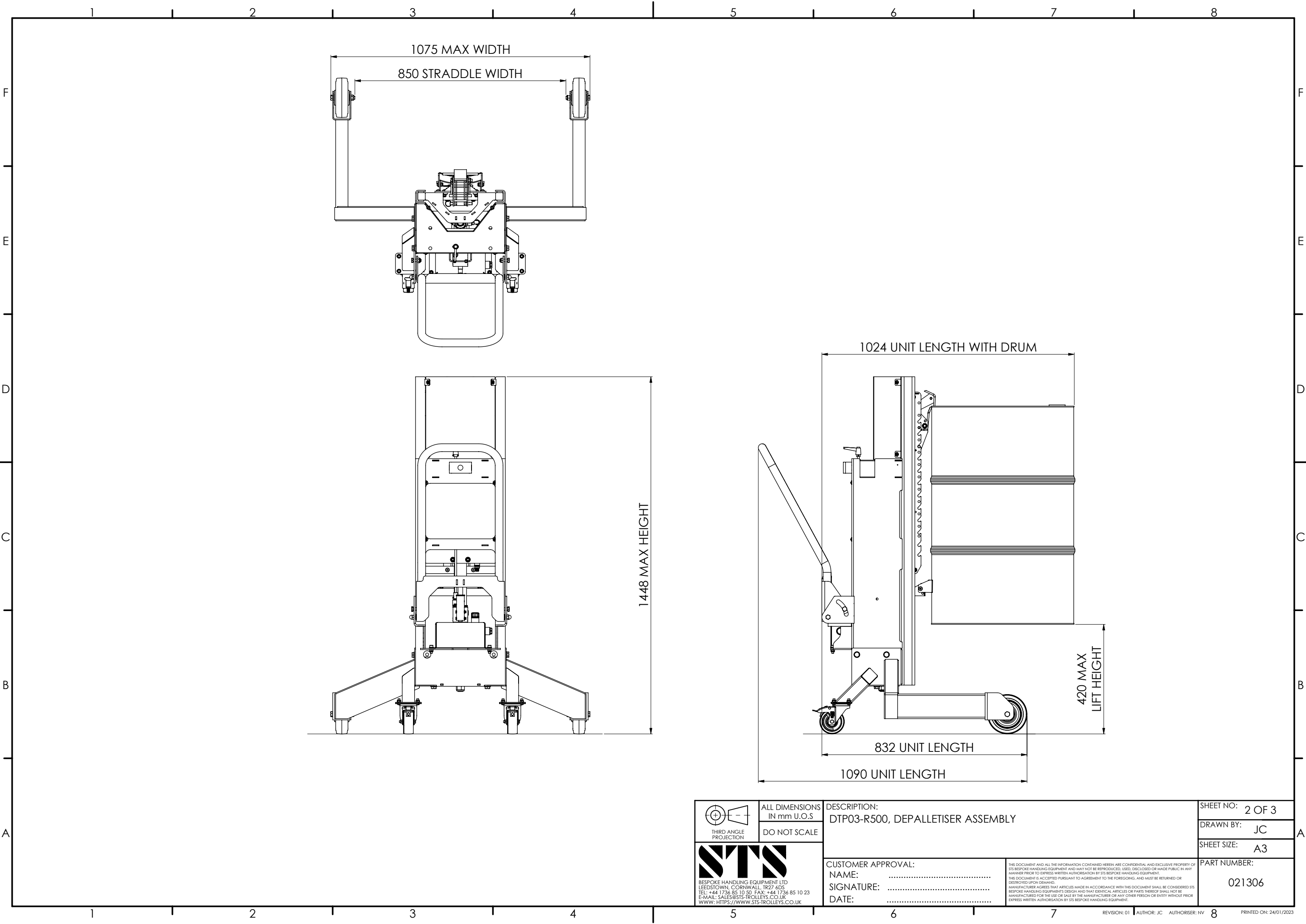
 THIRD ANGLE PROJECTION	ALL DIMENSIONS IN mm U.O.S	DESCRIPTION: DTP03-R500, DEPALLETER ASSEMBLY	SHEET NO: 1 OF 3
	DO NOT SCALE		DRAWN BY: JC
 BESPOKE HANDLING EQUIPMENT LTD LEEDSTOWN, CORNWALL, TR27 6DS TEL: +44 1736 85 10 50 FAX: +44 1736 85 10 23 E-MAIL: SALES@STS-TROLLEYS.CO.UK WWW: HTTPS://WWW.STS-TROLLEYS.CO.UK	CUSTOMER APPROVAL: NAME: ..... SIGNATURE: ..... DATE: .....		SHEET SIZE: A3
	<small>THIS DOCUMENT AND ALL THE INFORMATION CONTAINED HEREIN ARE CONFIDENTIAL AND EXCLUSIVE PROPERTY OF STS BESPOKE HANDLING EQUIPMENT AND MAY NOT BE REPRODUCED, USED, DISCLOSED OR MADE PUBLIC IN ANY MANNER PRIOR TO EXPRESS WRITTEN AUTHORIZATION BY STS BESPOKE HANDLING EQUIPMENT. THIS DOCUMENT IS ACCEPTED PURSUANT TO AGREEMENT TO THE FOREGOING, AND MUST BE RETURNED OR DESTROYED UPON DEMAND. MANUFACTURER AGREES THAT ARTICLES MADE IN ACCORDANCE WITH THIS DOCUMENT SHALL BE CONSIDERED STS BESPOKE HANDLING EQUIPMENT'S DESIGN AND THAT IDENTICAL ARTICLES OR PARTS THEREOF SHALL NOT BE MANUFACTURED FOR THE USE OR SALE BY THE MANUFACTURER OR ANY OTHER PERSON OR ENTITY WITHOUT PRIOR EXPRESS WRITTEN AUTHORIZATION BY STS BESPOKE HANDLING EQUIPMENT.</small>		PART NUMBER: 021306
	REVISION: 01 AUTHOR: JC AUTHORISER: NV		PRINTED ON: 24/01/2023

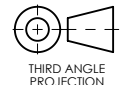

 THIRD ANGLE PROJECTION	ALL DIMENSIONS IN mm U.O.S	DESCRIPTION: DTP03-R500, DEPALLETER ASSEMBLY	SHEET NO: 2 OF 3
	DO NOT SCALE		DRAWN BY: JC
 BESPOKE HANDLING EQUIPMENT LTD LEEDSTOWN, CORNWALL, TR27 6DS TEL: +44 1736 85 10 50 FAX: +44 1736 85 10 23 E-MAIL: SALES@STS-TROLLEYS.CO.UK WWW: HTTPS://WWW.STS-TROLLEYS.CO.UK	CUSTOMER APPROVAL: NAME: ..... SIGNATURE: ..... DATE: .....		SHEET SIZE: A3
	<small>THIS DOCUMENT AND ALL THE INFORMATION CONTAINED HEREIN ARE CONFIDENTIAL AND EXCLUSIVE PROPERTY OF STS BESPOKE HANDLING EQUIPMENT AND MAY NOT BE REPRODUCED, USED, DISCLOSED OR MADE PUBLIC IN ANY MANNER PRIOR TO EXPRESS WRITTEN AUTHORIZATION BY STS BESPOKE HANDLING EQUIPMENT.          THIS DOCUMENT IS ACCEPTED PURSUANT TO AGREEMENT TO THE FOREGOING, AND MUST BE RETURNED OR DESTROYED UPON DEMAND.          MANUFACTURER AGREES THAT ARTICLES MADE IN ACCORDANCE WITH THIS DOCUMENT SHALL BE CONSIDERED STS BESPOKE HANDLING EQUIPMENT'S DESIGN AND THAT IDENTICAL ARTICLES OR PARTS THEREOF SHALL NOT BE MANUFACTURED FOR THE USE OR SALE BY THE MANUFACTURER OR ANY OTHER PERSON OR ENTITY WITHOUT PRIOR EXPRESS WRITTEN AUTHORIZATION BY STS BESPOKE HANDLING EQUIPMENT.</small>		PART NUMBER: 021306
	REVISION: 01 AUTHOR: JC AUTHORISER: NV		PRINTED ON: 24/01/2023