

# ITM01

**SWL - 1000kg**



	A		FIRST RELEASE	04/10/2018	JC
ZONE	REV.	ECN	DESCRIPTION	DATE	APPROVED
REVISIONS					

**ALL DIMENSIONS IN mm U.O.S**  
**DO NOT SCALE**

UNLESS OTHERWISE SPECIFIED THE FOLLOWING APPLY:  
 FABRICATED COMPONENTS DIMENSIONAL PRECISION  
 DECIMAL    METRIC    IMPERIAL    ANGLE  
 0.0        ±1.20mm    ±0.05"    ±0.50°    SIZE ≤ 1000MM  
 0.0        ±0.80mm    ±0.03"    ±0.25°    SIZE ≤ 1000MM  
 0.0        ±2.5mm     ±0.10"    ±0.50°    SIZE > 1000MM  
 0.0        ±1.5mm     ±0.06"    ±0.25°    SIZE > 1000MM  
 STANDARD SURFACE FINISH RA 63MM [RA 250MIN]  
 BREAK ALL SHARP CORNERS AND EDGES. R 0.3mm MAX

CATEGORY: ASSEMBLY

SHEET NO: 1 OF 4    DRAWN BY: JC

MATERIAL SPEC:

EST MASS: 79.58kg    CHECKED BY: JC

FINISH: N/A

SHEET SIZE: A4    DATE CHK: 18/06/2020

DESCRIPTION: ITM01, IBC TIPPER, MILD STEEL

PART NUMBER:    REVISION:

016988    A

  
**BESPOKE HANDLING EQUIPMENT LTD**  
 LEEDSTOWN, CORNWALL, TR27 6DS  
 TEL: +44 1736 85 10 50 FAX: +44 1736 85 10 23  
 E-MAIL: SALES@STS-TROLLEYS.CO.UK  
 WWW: HTTPS://WWW.STS-TROLLEYS.CO.UK

THIS DOCUMENT AND ALL THE INFORMATION CONTAINED HEREIN ARE CONFIDENTIAL AND EXCLUSIVE PROPERTY OF STS BESPOKE HANDLING EQUIPMENT AND MAY NOT BE REPRODUCED, USED, DISCLOSED OR MADE PUBLIC IN ANY MANNER PRIOR TO EXPRESS WRITTEN AUTHORISATION BY STS BESPOKE HANDLING EQUIPMENT.  
 THIS DOCUMENT IS ACCEPTED PURSUANT TO AGREEMENT TO THE FOREGOING, AND MUST BE RETURNED OR DESTROYED UPON DEMAND.  
 MANUFACTURER AGREES THAT ARTICLES MADE IN ACCORDANCE WITH THIS DOCUMENT SHALL BE CONSIDERED STS BESPOKE HANDLING EQUIPMENT'S DESIGN AND THAT IDENTICAL ARTICLES OR PARTS THEREOF SHALL NOT BE MANUFACTURED FOR THE USE OR SALE BY THE MANUFACTURER OR ANY OTHER PERSON OR ENTITY WITHOUT PRIOR EXPRESS WRITTEN AUTHORISATION BY STS BESPOKE HANDLING EQUIPMENT.

# ITM01

SWL - 1000kg

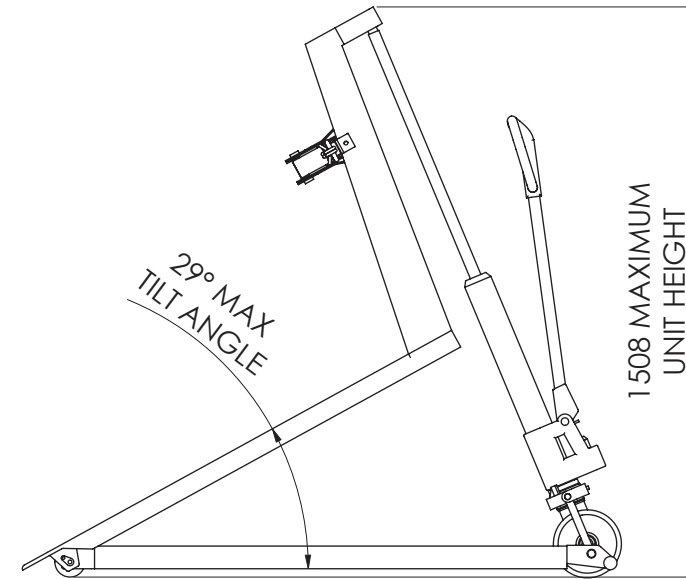
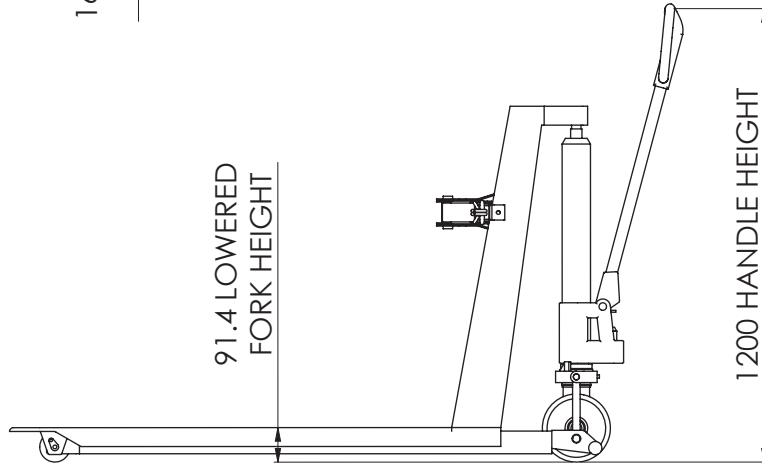
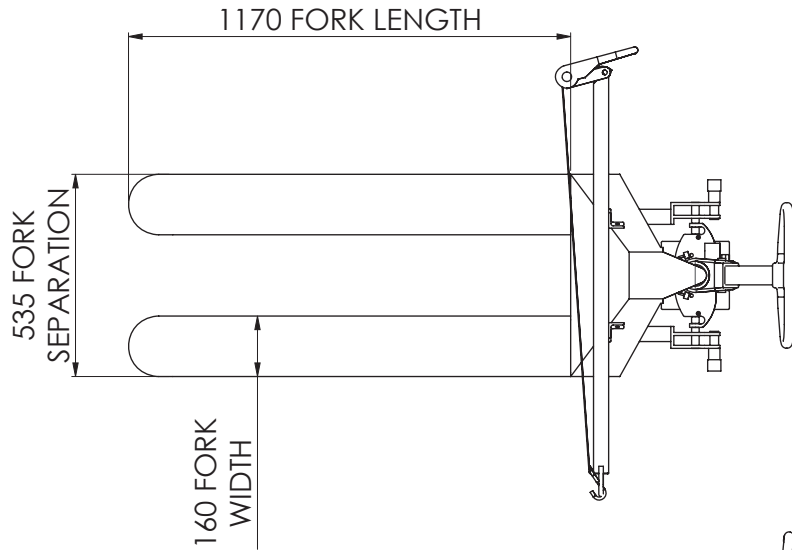

	**		FIRST RELEASE	04/10/2018	
ZONE	REV.	ECN	DESCRIPTION	DATE	APPROVED
REVISIONS					

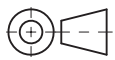

THIRD ANGLE PROJECTION

ALL DIMENSIONS IN mm U.O.S

DO NOT SCALE

UNLESS OTHERWISE SPECIFIED THE FOLLOWING APPLY:  
 FABRICATED COMPONENTS DIMENSIONAL PRECISION  
 DECIMAL METRIC IMPERIAL ANGLE  
 0, ±1.20mm ±0.05" ±0.50" SIZE ≤ 1000MM  
 0,0 ±0.80mm ±0.03" ±0.25" SIZE ≤ 1000MM  
 0, ±2.5mm ±0.10" ±0.50" SIZE > 1000MM  
 0,0 ±1.5mm ±0.06" ±0.25" SIZE > 1000MM  
 STANDARD SURFACE FINISH RA 63MM [RA 250MIN]  
 BREAK ALL SHARP CORNERS AND EDGES. R 0.3mm MAX

CATEGORY: ASSEMBLY

MATERIAL SPEC:

FINISH: N/A

DESCRIPTION: ITM01, IBC TIPPER, MILD STEEL

SHEET NO: 2 OF 4

EST MASS: 79.58kg

SHEET SIZE: A4

PART NUMBER:  
016988

DRAWN BY: JC

CHECKED BY: JC

DATE CHK: 18/06/2020

REVISION:  
A



BESPOKE HANDLING EQUIPMENT LTD  
 LEEDSTOWN, CORNWALL, TR27 6DS  
 TEL: +44 1736 85 10 50 FAX: +44 1736 85 10 23  
 E-MAIL: SALES@STS-TROLLEYS.CO.UK  
 WWW: HTTPS://WWW.STS-TROLLEYS.CO.UK

THIS DOCUMENT AND ALL THE INFORMATION CONTAINED HEREIN ARE CONFIDENTIAL AND EXCLUSIVE PROPERTY OF STS BESPOKE HANDLING EQUIPMENT AND MAY NOT BE REPRODUCED, USED, DISCLOSED OR MADE PUBLIC IN ANY MANNER PRIOR TO EXPRESS WRITTEN AUTHORISATION BY STS BESPOKE HANDLING EQUIPMENT.  
 THIS DOCUMENT IS ACCEPTED PURSUANT TO AGREEMENT TO THE FOREGOING, AND MUST BE RETURNED OR DESTROYED UPON DEMAND.  
 MANUFACTURER AGREES THAT ARTICLES MADE IN ACCORDANCE WITH THIS DOCUMENT SHALL BE CONSIDERED STS BESPOKE HANDLING EQUIPMENT'S DESIGN AND THAT IDENTICAL ARTICLES OR PARTS THEREOF SHALL NOT BE MANUFACTURED FOR THE USE OR SALE BY THE MANUFACTURER OR ANY OTHER PERSON OR ENTITY WITHOUT PRIOR EXPRESS WRITTEN AUTHORISATION BY STS BESPOKE HANDLING EQUIPMENT.

# ITM01

SWL - 1000kg

ONLY SUITABLE FOR USE WITH OPEN BOTTOM IBC'S

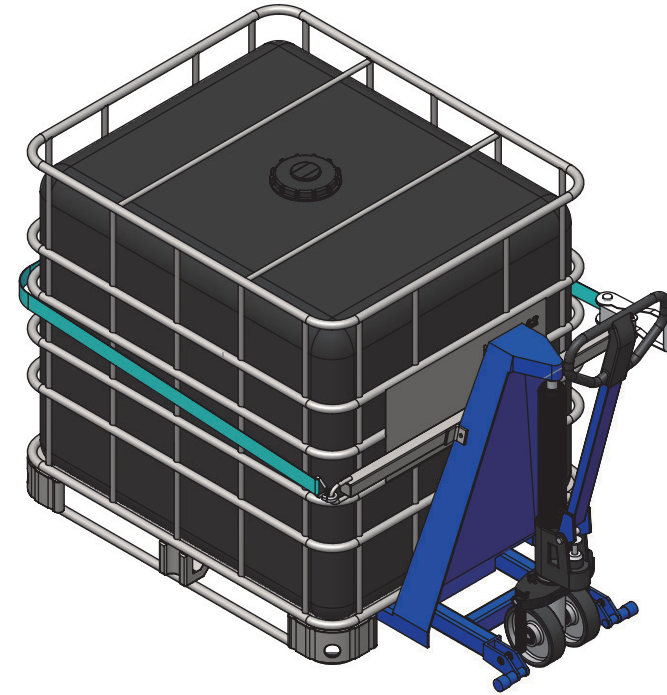
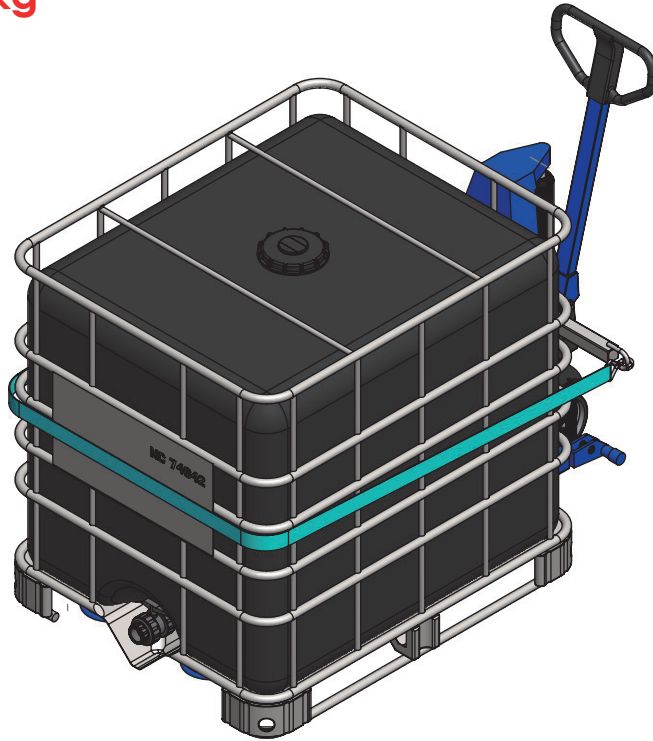

	**		FIRST RELEASE	04/10/2018	
ZONE	REV.	ECN	DESCRIPTION	DATE	APPROVED
REVISIONS					

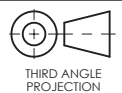

THIRD ANGLE PROJECTION

ALL DIMENSIONS IN mm U.O.S

DO NOT SCALE

UNLESS OTHERWISE SPECIFIED THE FOLLOWING APPLY:  
 FABRICATED COMPONENTS DIMENSIONAL PRECISION  
 DECIMAL METRIC IMPERIAL ANGLE  
 0, ±1.20mm ±0.05" ±0.50° SIZE ≤ 1000MM  
 0,0 ±0.80mm ±0.03" ±0.25° SIZE ≤ 1000MM  
 0, ±2.5mm ±0.10" ±0.50° SIZE > 1000MM  
 0,0 ±1.5mm ±0.06" ±0.25° SIZE > 1000MM  
 STANDARD SURFACE FINISH RA 63MM [RA 250MIN]  
 BREAK ALL SHARP CORNERS AND EDGES, R 0.3mm MAX

CATEGORY: ASSEMBLY

MATERIAL SPEC:

FINISH: N/A

DESCRIPTION: ITM01, IBC TIPPER, MILD STEEL

SHEET NO: 3 OF 4

DRAWN BY: JC

EST MASS: 79.58kg

CHECKED BY: JC

SHEET SIZE: A4

DATE CHK: 18/06/2020

PART NUMBER:  
016988

REVISION:  
A



BESPOKE HANDLING EQUIPMENT LTD  
 LEEDSTOWN, CORNWALL, TR27 6DS  
 TEL: +44 1736 85 10 50 FAX: +44 1736 85 10 23  
 E-MAIL: SALES@STS-TROLLEYS.CO.UK  
 WWW: HTTPS://WWW.STS-TROLLEYS.CO.UK

THIS DOCUMENT AND ALL THE INFORMATION CONTAINED HEREIN ARE CONFIDENTIAL AND EXCLUSIVE PROPERTY OF STS BESPOKE HANDLING EQUIPMENT AND MAY NOT BE REPRODUCED, USED, DISCLOSED OR MADE PUBLIC IN ANY MANNER PRIOR TO EXPRESS WRITTEN AUTHORIZATION BY STS BESPOKE HANDLING EQUIPMENT.  
 THIS DOCUMENT IS ACCEPTED PURSUANT TO AGREEMENT TO THE FOREGOING, AND MUST BE RETURNED OR DESTROYED UPON DEMAND.  
 MANUFACTURER AGREES THAT ARTICLES MADE IN ACCORDANCE WITH THIS DOCUMENT SHALL BE CONSIDERED STS BESPOKE HANDLING EQUIPMENT'S DESIGN AND THAT IDENTICAL ARTICLES OR PARTS THEREOF SHALL NOT BE MANUFACTURED FOR THE USE OR SALE BY THE MANUFACTURER OR ANY OTHER PERSON OR ENTITY WITHOUT PRIOR EXPRESS WRITTEN AUTHORIZATION BY STS BESPOKE HANDLING EQUIPMENT.