

GHD\$, !: 57 \$% %\$\$\$?; !9L

GK @! %\$\$\$_ [

7 @95B 'A @8 'GH9@7 C BGF I 7 HC B

5BH#GH5H7 '7 @95F
DC @M 5F6C B5H9; I 5F8-B;

<MBF5I @7 '@=HF5A
: #H98 'K #k '6I FGJ 5@9

GDF-B; 'F9H FB 'F95F
A C I B H98 'H@9F

58> GH56@'K -8H
GH5-B @GG'GH9@7 @58': C F?G



GH5-B @GG'GH9@DFC H97 H98
7 C B H57 HDC -B HG

%\$A A '
F95F '6F5?98 '7 5GH C FG'
K #k '5BH#GH5H7 'K <99@G

; F #H6@GH98 '5B8
DC K 89F '7 C 5H98': B-G<

: #H98 'K #k '95FH-B; '7 <5-BG

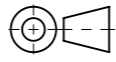
%\$A A
<95J M8I HM
5BH#GH5H7 'K <99@G

 H-48 5B: @9 DFC -97 HCB	5 @8-A 9BGC BG -B'a a 1"C"G	71 G C A 9F '5DDFC J 5@	75H9; CFM	5 GG9A 6@M	G<99HBC. %C: '(8F5K B 6M >7	
	8C BCHG7 5@9	B5A 9..... G# B5H F9..... 85H9.....	A 5H9F-5@GD97.	B #5	9GHA 5GG *,-") ([7 <97?98 6M >7	
 69XDC 79<5B8@B: '9E I 4A 95H@B @99B@C K B27 C F B K 5 @M F @= '9G H@= Z ((% " ")) %S 'S: 5L Z ((% " ")) %S @' 9A 5 @G 5@G4 G@HFC @M@C7 C T ? K K K: <HDG #K K 'G@H C @M@7 C T ?		H-GBC71 A 9H5B8 5@M@9-B: CFA 5HCB 7CBH6@B -9F@B 5F7CB: @9H@5B8 9L7@G 9DFC DFH@C: @G@XDC 79<5B8@B: '9E I 4A 95H@B A 5@M@C H@9 F@9C @I 7 9@I @B@B @7 H@C @B C F A 5@9D @M@ B 5@M A 5@B@F @F @F H@C 9@C@ F@H@B S I H@C F@C @H@C @G@C@G@C 79<5B8@B: '9E I 4A 9@H H-GBC71 A 9H@577@M@B @I F@G 5@H@C 5: F@9@H@C 1@9: C F@: C B: 25@B A I @H@F@H F@B@C F @M@C M@I DC B @9@ 5@B@ A 5@I: 57@H@9@: F@G@H@5@H@M@A 5@B@ 577 C F@B@7@9@ @H-GBC71 A 9H@C 5@M@7 C B@G@9@B@G @XDC 79<5B8@B: '9E I 4A 9@H@B@G: B 5@B H@5@H@9@H@S H@Z @M@C T @S F@H@9@C: G: 5@M@C H@9 A 5@I: 57@H@9@: C F@H@9@C F@G@H@M@A 5@B@: 57@H@F@C F@S@M@H@9@ D@G@C B C F@H@M@K H@C I H@F@C F @L@F@G@C F@H@B S I H@C F@C @H@C @G@C@G@C 79<5B8@B: '9E I 4A 9@H	89G7 F @HC B.	GHD\$, !: 57 \$% %\$\$\$?; !9L Z 5H9L 'F5H98 'H@9G7 C D-7 DB9I A 5H7 'GH5?9F 'K #k 'GH5-B @GG'GH9@7 @58' 58> GH56@: C F?G %\$\$\$?; 'GK @	G<99H@M@. 5'	85H9' %\$#%#&\$&\$ 7<?.	F9J -GC B. 5
					\$%* &%		

GHD\$, !: 57 \$%\$\$\$?; !9L

GK @! '\$\$\$\$_ [

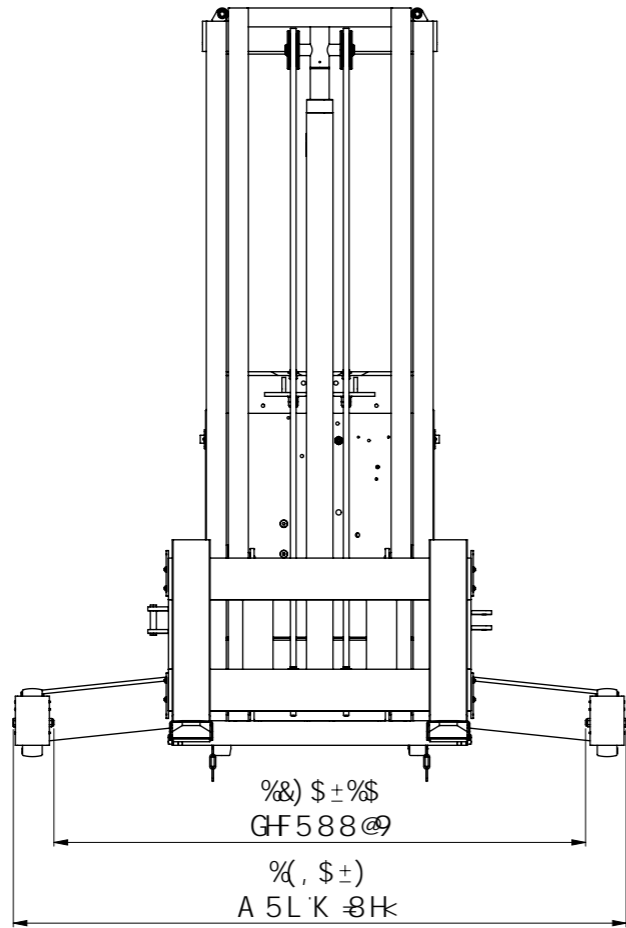
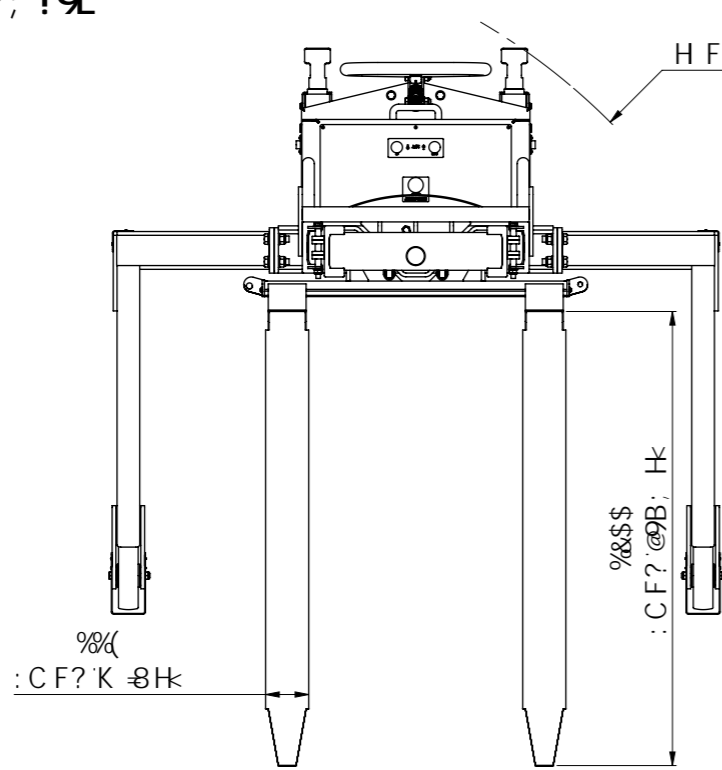

&+,) ±%\$
<9± <HHC HC DC: : CF?G

-) ±)
: CF? 7 @5F5B79

% \$
@; <9± <H7 @5F5B79

) \$
: CF? 89DHK

% \$ \$±%\$
A 5L @9B; HK

' '\$±%\$
A 5L <9± <H

% , \$ ±%\$
A 5GH <9± <H

' \$±)
: FC I B 8 7 @5F5B79

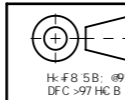

5 @8 A 9BGC BG
B'a a 1 "C"G
8C BCHG7 5 @



71 GC A 9F 5DDFC J 5 @

B5A 9.

G± B5H F9.

85H±.

75H± CFM

5 GG9A 6 @M

A 5H±F-5 @GD97.

: B G±.

B #5

89G7 F DHC B.

GHD\$, !: 57 \$%\$\$\$?; !9L Ž5H L F5H8 H @9G7 C D 7
DB 9I A 5H7 'G5 7. ?9F 'K ±: 'G5 B @9G GH9 @7 5 8
5 8 > I G5 6 @: C F? G± \$\$\$?; 'GK @

G< 99HBC.

&C : (

8F5K B 6M >7

9GHA 5GG

* , -) (_ [

7 < 97 ? 98 6M >7

G< 99HGAP.

5'

85H± %\$#%#&\$&\$

D5FHBI A 69F.

\$%* &%

F9J GCB.

5

GHD\$, !: 57 \$%\$\$\$?; !9L

GK @! %\$\$\$_ [

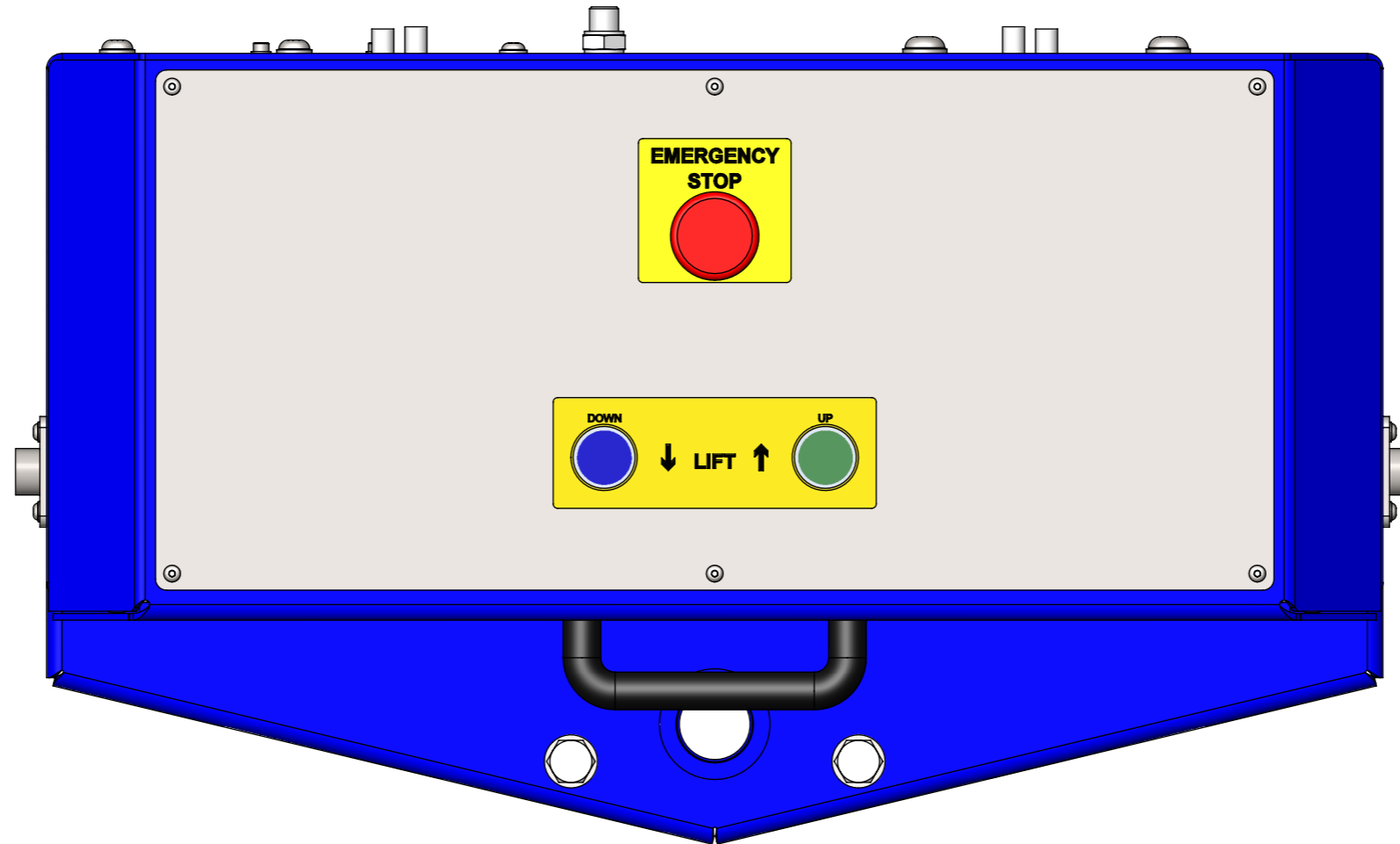

	5@@8 A 9BGC BG B'a a 1 "C "G	71 G C A 9F '5DDFC J 5@	75H; CFM	5 GG9A 6@M	G< 99HBC.	8F5K B 6M
	8C BCHG7 5@	B5A 9.	A 5H9F-5@GD97.		9GHA 5GG	7 <97 ?98 6M
		G B5H F9.	: B G<.	B #5	G< 99HGAN.	85H? %\$#%#&\$&\$
		85H9.	89G7 F DHC B.	GHD\$, !: 57 \$%\$\$\$?; !9Lž5H9L F5H98 'H@9G7 C D=7	D5FHBI A 69F.	F9J G C B.
				DB9I A 5H7 'G5 7 ?9F 'K #K 'G5 B @9GGH99@7 @58'	\$%* &%	5
				58>I G5 6@: C F ?G?%\$\$\$?; 'GK @		