

(\varnothing 608 INT. DIA)

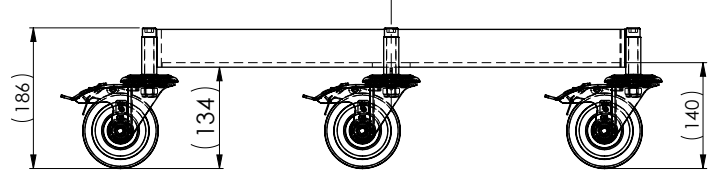

BRUSHED STAINLESS STEEL CONSTRUCTION

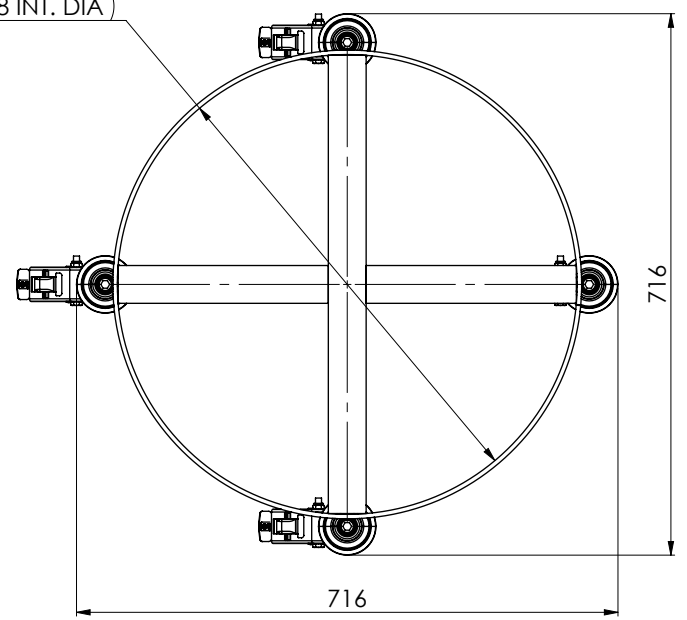
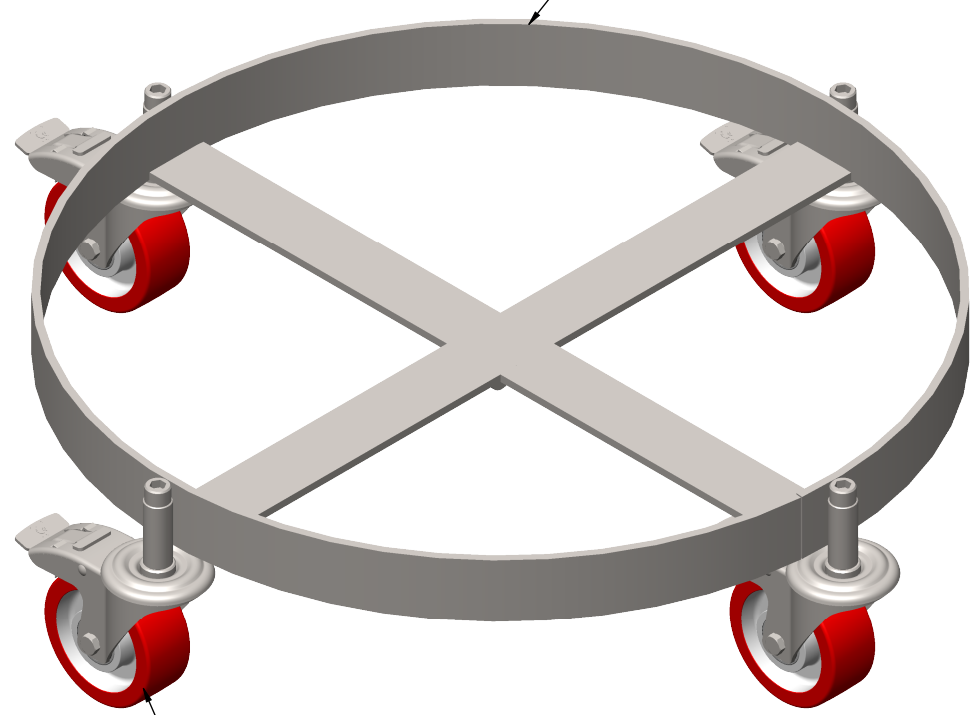

STAINLESS STEEL BRAKED SWIVEL CASTOR BRACKETS WITH 100MM DIAMETER WHEELS

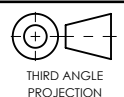

ALL DIMENSIONS IN mm U.O.S
DO NOT SCALE

UNLESS OTHERWISE SPECIFIED THE FOLLOWING APPLY:
FABRICATED COMPONENTS DIMENSIONAL PRECISION
DECIMAL METRIC IMPERIAL ANGLE
0.0 ±1.20mm ±0.05° ±0.50° SIZE ≤ 1000MM
0.0 ±0.80mm ±0.03° ±0.25° SIZE ≤ 1000MM
0.0 ±2.5mm ±0.10° ±0.50° SIZE > 1000MM
0.0 ±1.5mm ±0.06° ±0.25° SIZE > 1000MM
STANDARD SURFACE FINISH RA 63MM [RA 250MIN]
BREAK ALL SHARP CORNERS AND EDGES, R 0.3mm MAX

CATEGORY: ASSEMBLY

SHEET NO: 1 OF 1

DRAWN BY: JS

MATERIAL SPEC: N/A

EST MASS: 11.51kg

CHECKED BY: JS

FINISH: N/A

SHEET SIZE: A4

DATE CHK: 03/11/2025

DESCRIPTION: DDL01-SS, DRUM DOLLY, ASSEMBLY, STAINLESS STEEL

PART NUMBER:

REVISION:

015823

C

STS
BESPOKE HANDLING EQUIPMENT LTD
LEEDSTOWN, CORNWALL, TR27 6DS
TEL: +44 1736 85 10 50 FAX: +44 1736 85 10 23
E-MAIL: SALES@STS-TROLLEYS.CO.UK
WWW: HTTPS://WWW.STS-TROLLEYS.CO.UK

THIS DOCUMENT AND ALL THE INFORMATION CONTAINED HEREIN ARE CONFIDENTIAL AND EXCLUSIVE PROPERTY OF STS BESPOKE HANDLING EQUIPMENT AND MAY NOT BE REPRODUCED, USED, DISCLOSED OR MADE PUBLIC IN ANY MANNER PRIOR TO EXPRESS WRITTEN AUTHORISATION BY STS BESPOKE HANDLING EQUIPMENT.
THIS DOCUMENT IS ACCEPTED PURSUANT TO AGREEMENT TO THE FOREGOING, AND MUST BE RETURNED OR DESTROYED UPON DEMAND.
MANUFACTURER AGREES THAT ARTICLES MADE IN ACCORDANCE WITH THIS DOCUMENT SHALL BE CONSIDERED STS BESPOKE HANDLING EQUIPMENT'S DESIGN AND THAT IDENTICAL ARTICLES OR PARTS THEREOF SHALL NOT BE MANUFACTURED FOR THE USE OR SALE BY THE MANUFACTURER OR ANY OTHER PERSON OR ENTITY WITHOUT PRIOR EXPRESS WRITTEN AUTHORISATION BY STS BESPOKE HANDLING EQUIPMENT.