

STP01-RRH01-Ex

SWL - 300KG

CLEAN MILD STEEL CONSTRUCTION,
SHOT BLASTED, ZINC PRIMER
AND POWDERCOATED FINISH

PNEUMATIC POWERED
HYDRAULIC LIFT
AND LOWER

CLEAR ANTI-STATIC
POLYCARBONATE
GUARDING

HYDRAULIC POWERED
CLAMP AND 360
DEGREE ROTATION

3 FUNCTION
CONTROL BOX

FEMALE 3/8" BSP INPUT
(ONE ON EACH SIDE)

850mm STRADDLE LEGS

160mm ANTI-STATIC CASTORS
WITH PARKING BRAKES

160mm ANTI-STATIC
FRONT WHEELS

EARTHING CHAINS

Ex II 2 G D

Ex h IIB T4 Gb

Ex h IIIB T135°C Db

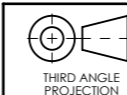

ALL DIMENSIONS
IN mm U.O.S
DO NOT SCALE



BESPOKE HANDLING EQUIPMENT LTD
LEEDSTOWN, CORNWALL, TR27 6DS
TEL: +44 1736 85 10 50 FAX: +44 1736 85 10 23
E-MAIL: SALES@STIS-TROLLEYS.CO.UK
WWW: HTTPS://WWW.STIS-TROLLEYS.CO.UK

DESCRIPTION:
STP01-RRH01-EX, PNEUMATIC STACKER WITH POWERED CLAMP AND
ROTATE HEAD

CUSTOMER APPROVAL:

NAME:
SIGNATURE:
DATE:

THIS DOCUMENT AND ALL THE INFORMATION CONTAINED HEREIN ARE CONFIDENTIAL AND EXCLUSIVE PROPERTY OF STS BESPOKE HANDLING EQUIPMENT AND MAY NOT BE REPRODUCED, USED, DISCLOSED OR MADE PUBLIC IN ANY MANNER PRIOR TO EXPRESS WRITTEN AUTHORIZATION BY STS BESPOKE HANDLING EQUIPMENT.
THIS DOCUMENT IS ACCEPTED PURSUANT TO AGREEMENT TO THE FOREGOING, AND MUST BE RETURNED OR DESTROYED UPON DEMAND.
MANUFACTURER AGREES THAT ARTICLES MADE IN ACCORDANCE WITH THIS DOCUMENT SHALL BE CONSIDERED STS BESPOKE HANDLING EQUIPMENT'S DESIGN AND THAT IDENTICAL ARTICLES OR PARTS THEREOF SHALL NOT BE MANUFACTURED FOR THE USE OR SALE BY THE MANUFACTURER OR ANY OTHER PERSON OR ENTITY WITHOUT PRIOR EXPRESS WRITTEN AUTHORIZATION BY STS BESPOKE HANDLING EQUIPMENT.

SHEET NO: 1 OF 4



DRAWN BY: JC

SHEET SIZE: A3

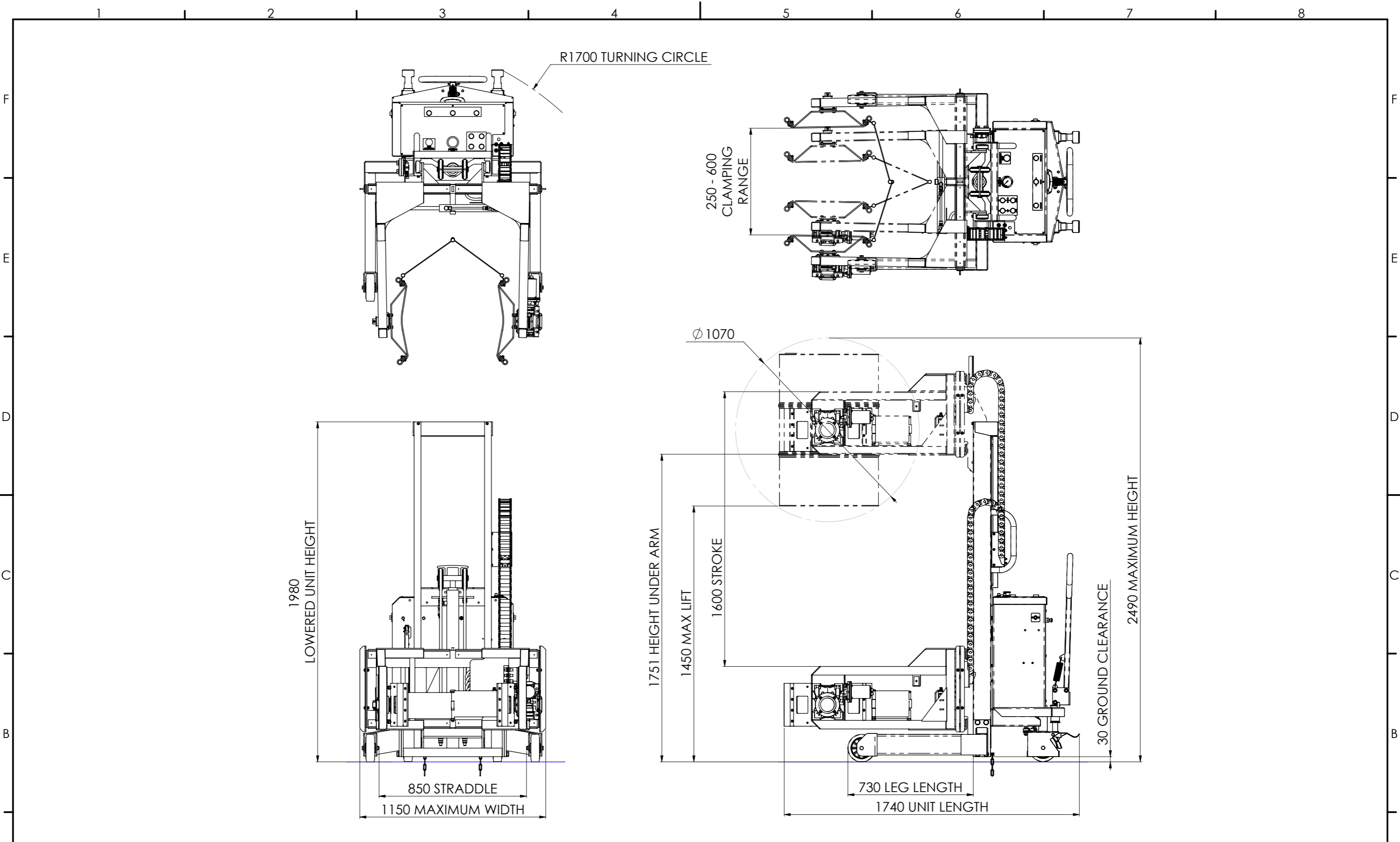

PART NUMBER:

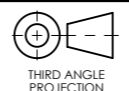
012484



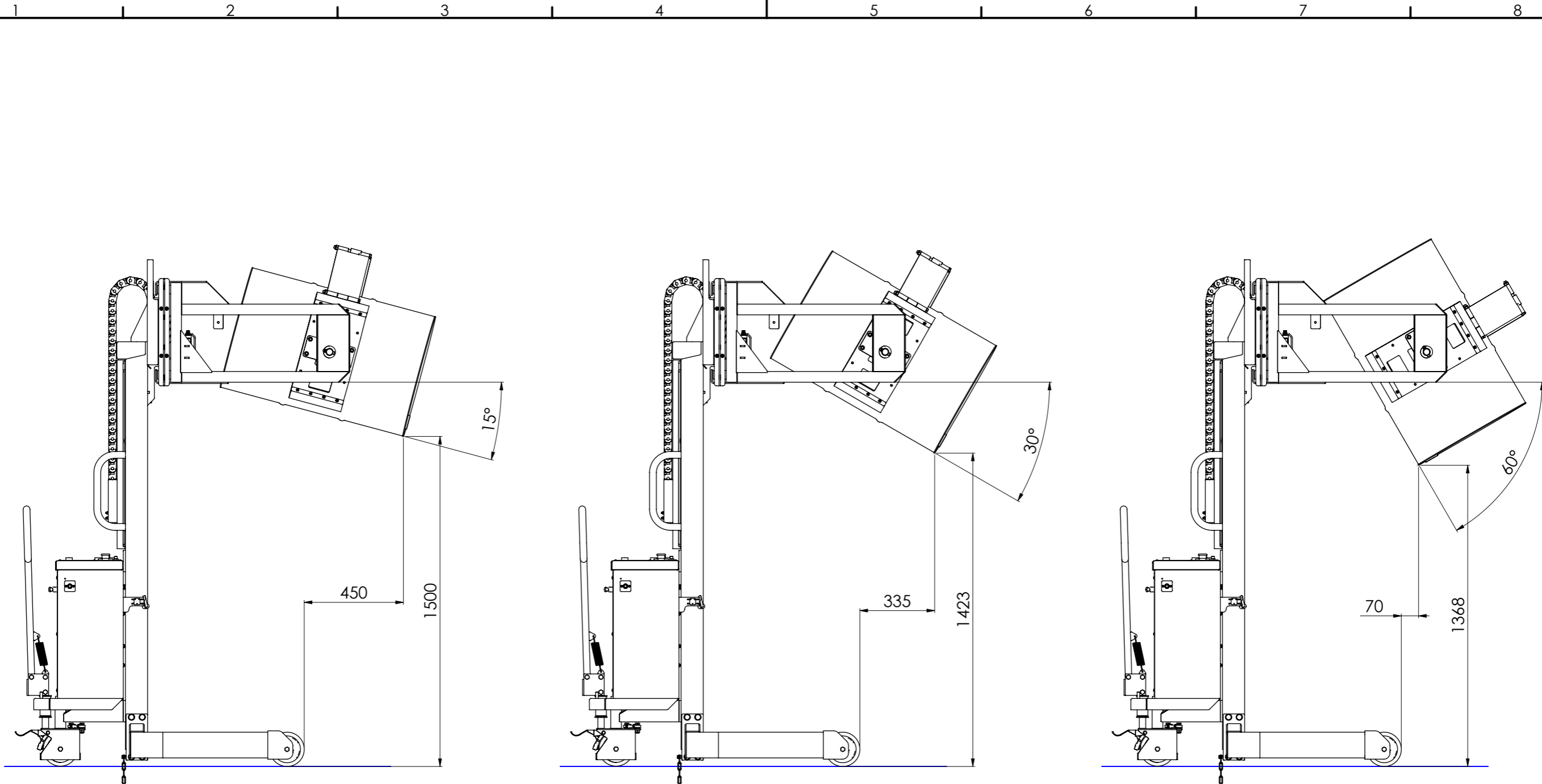

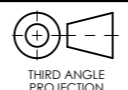
| | | | |
|---|--|--|--|
|  THIRD ANGLE PROJECTION | ALL DIMENSIONS IN mm U.O.S DO NOT SCALE | DESCRIPTION: STP01-RRH01-EX, PNEUMATIC STACKER WITH POWERED CLAMP AND ROTATE HEAD | SHEET NO: 2 OF 4 |
| |  BESPOKE HANDLING EQUIPMENT LTD LEEDSTOWN, CORNWALL, TR27 6DS TEL: +44 1736 85 10 50 FAX: +44 1736 85 10 23 E-MAIL: SALES@STN-TROLLEYS.CO.UK WWW: HTTPS://WWW.STN-TROLLEYS.CO.UK | | CUSTOMER APPROVAL: NAME: SIGNATURE: DATE: |
| | | <small>THIS DOCUMENT AND ALL THE INFORMATION CONTAINED HEREIN ARE CONFIDENTIAL AND EXCLUSIVE PROPERTY OF STS BESPOKE HANDLING EQUIPMENT AND MAY NOT BE REPRODUCED, USED, DISCLOSED OR MADE PUBLIC IN ANY MANNER PRIOR TO EXPRESS WRITTEN AUTHORIZATION BY STS BESPOKE HANDLING EQUIPMENT. THIS DOCUMENT IS ACCEPTED PURSUANT TO AGREEMENT TO THE FOREGOING, AND MUST BE RETURNED OR DESTROYED UPON DEMAND. MANUFACTURER AGREES THAT ARTICLES MADE IN ACCORDANCE WITH THIS DOCUMENT SHALL BE CONSIDERED STS BESPOKE HANDLING EQUIPMENT'S DESIGN AND THAT IDENTICAL ARTICLES OR PARTS THEREOF SHALL NOT BE MANUFACTURED FOR THE USE OR SALE BY THE MANUFACTURER OR ANY OTHER PERSON OR ENTITY WITHOUT PRIOR EXPRESS WRITTEN AUTHORIZATION BY STS BESPOKE HANDLING EQUIPMENT.</small> | PART NUMBER: 012484 |

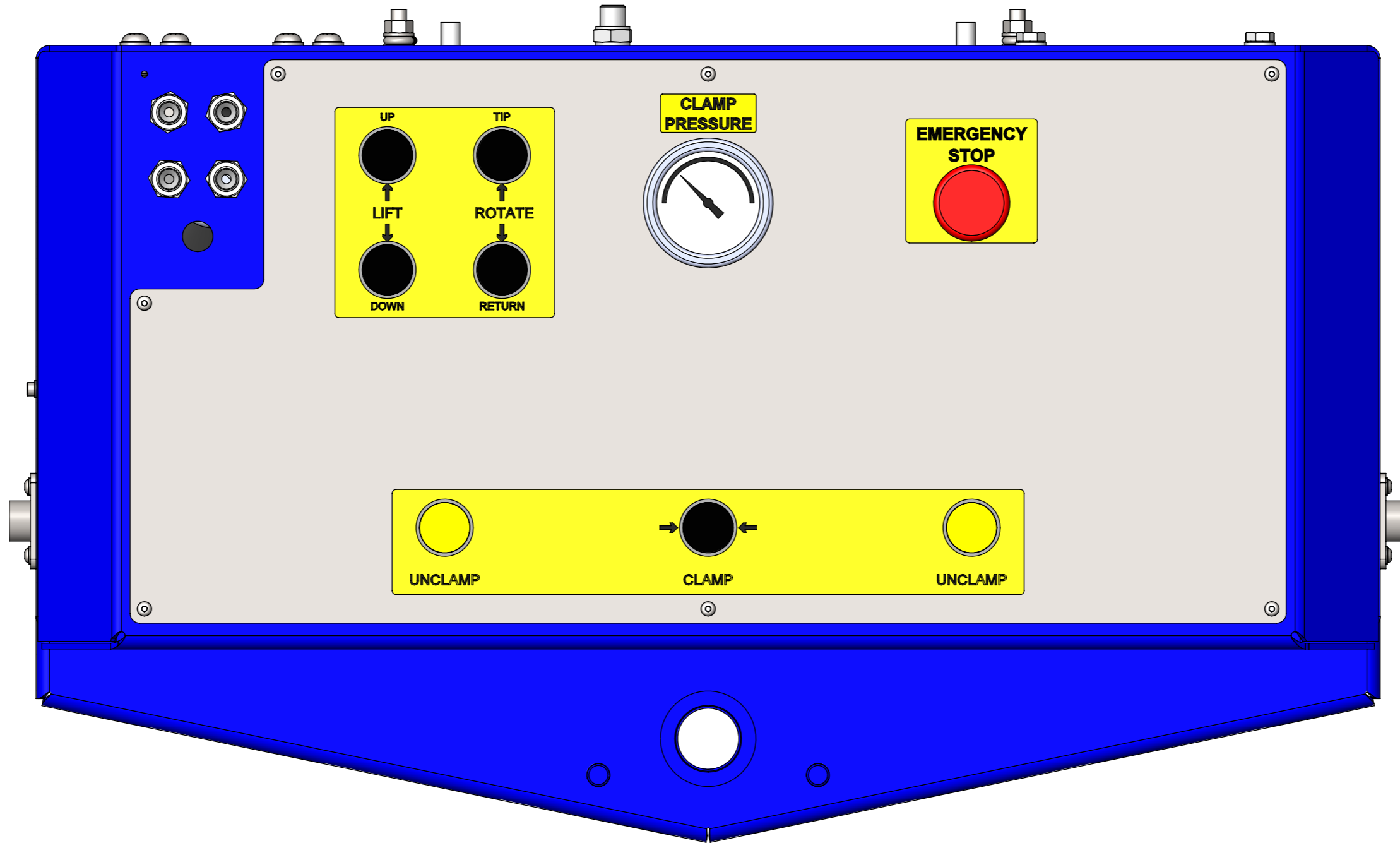

| | | | |
|---|--|--|--|
|  THIRD ANGLE PROJECTION | ALL DIMENSIONS IN mm U.O.S. DO NOT SCALE | DESCRIPTION: STP01-RRH01-EX, PNEUMATIC STACKER WITH POWERED CLAMP AND ROTATE HEAD | SHEET NO: 3 OF 4 |
| |  BESPOKE HANDLING EQUIPMENT LTD LEEDSTOWN, CORNWALL, TR27 6DS TEL: +44 1736 85 10 50 FAX: +44 1736 85 10 23 E-MAIL: SALES@STS-TROLLEYS.CO.UK WWW: HTTPS://WWW.STS-TROLLEYS.CO.UK | | CUSTOMER APPROVAL: NAME: SIGNATURE: DATE: |
| | | <small>THIS DOCUMENT AND ALL THE INFORMATION CONTAINED HEREIN ARE CONFIDENTIAL AND EXCLUSIVE PROPERTY OF STS BESPOKE HANDLING EQUIPMENT AND MAY NOT BE REPRODUCED, USED, DISCLOSED OR MADE PUBLIC IN ANY MANNER PRIOR TO EXPRESS WRITTEN AUTHORIZATION BY STS BESPOKE HANDLING EQUIPMENT. THIS DOCUMENT IS ACCEPTED PURSUANT TO AGREEMENT TO THE FOREGOING, AND MUST BE RETURNED OR DESTROYED UPON DEMAND. MANUFACTURER AGREES THAT ARTICLES MADE IN ACCORDANCE WITH THIS DOCUMENT SHALL BE CONSIDERED STS BESPOKE HANDLING EQUIPMENT'S DESIGN AND THAT IDENTICAL ARTICLES OR PARTS THEREOF SHALL NOT BE MANUFACTURED FOR THE USE OR SALE BY THE MANUFACTURER OR ANY OTHER PERSON OR ENTITY WITHOUT PRIOR EXPRESS WRITTEN AUTHORIZATION BY STS BESPOKE HANDLING EQUIPMENT.</small> | PART NUMBER: 012484 |

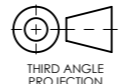

| | | | |
|---|--|--|--|
|  THIRD ANGLE PROJECTION | ALL DIMENSIONS IN mm U.O.S. DO NOT SCALE | DESCRIPTION: STP01-RRH01-EX, PNEUMATIC STACKER WITH POWERED CLAMP AND ROTATE HEAD | SHEET NO: 4 OF 4 |
| |  BESPOKE HANDLING EQUIPMENT LTD LEEDSTOWN, CORNWALL, TR27 6DS TEL: +44 1736 85 10 50 FAX: +44 1736 85 10 23 E-MAIL: SALES@STN-TROLLEYS.CO.UK WWW: HTTPS://WWW.STN-TROLLEYS.CO.UK | | CUSTOMER APPROVAL: NAME: SIGNATURE: DATE: |
| | | <small>THIS DOCUMENT AND ALL THE INFORMATION CONTAINED HEREIN ARE CONFIDENTIAL AND EXCLUSIVE PROPERTY OF STN BESPOKE HANDLING EQUIPMENT AND MAY NOT BE REPRODUCED, USED, DISCLOSED OR MADE PUBLIC IN ANY MANNER PRIOR TO EXPRESS WRITTEN AUTHORIZATION BY STN BESPOKE HANDLING EQUIPMENT. THIS DOCUMENT IS ACCEPTED PURSUANT TO AGREEMENT TO THE FOREGOING, AND MUST BE RETURNED OR DESTROYED UPON DEMAND. MANUFACTURER AGREES THAT ARTICLES MADE IN ACCORDANCE WITH THIS DOCUMENT SHALL BE CONSIDERED STN BESPOKE HANDLING EQUIPMENT'S DESIGN AND THAT IDENTICAL ARTICLES OR PARTS THEREOF SHALL NOT BE MANUFACTURED FOR THE USE OR SALE BY THE MANUFACTURER OR ANY OTHER PERSON OR ENTITY WITHOUT PRIOR EXPRESS WRITTEN AUTHORIZATION BY STN BESPOKE HANDLING EQUIPMENT.</small> | PART NUMBER: 012484 |