

# Operating Instructions

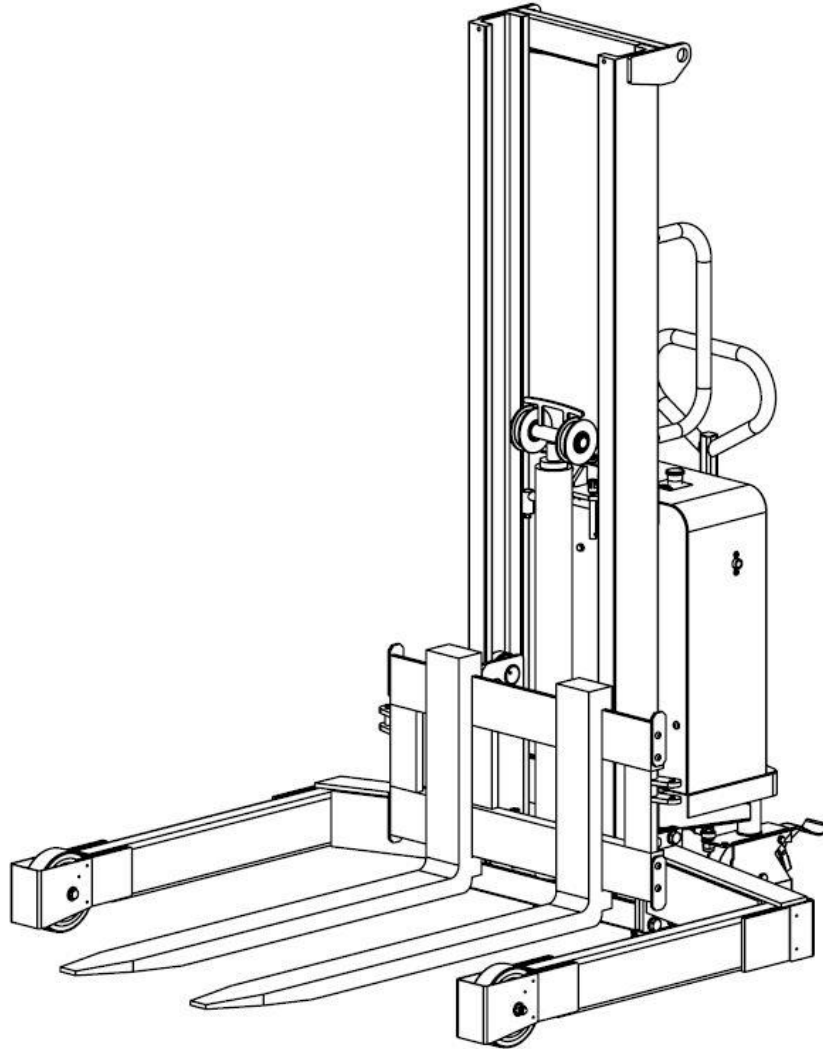

## STP07-FAC01-Ex

ATEX Rated Pneumatic Hydraulic Stacker with  
Stainless Clad Forks

Bespoke Handling Equipment Ltd.  
Leedstown  
Hayle  
Penzance  
TR27 6DS

E-mail: [sales@sts-trolleys.co.uk](mailto:sales@sts-trolleys.co.uk)  
Tel: +44 (0)1736 851050  
Fax: +44 (0)1736 851023

<b>Section I – Correct Use and Application</b> .....	<b>2</b>
<b>Section II – Unit Description</b> .....	<b>5</b>
<b>Section III – Unit Operation</b> .....	<b>6</b>
Set Up .....	6
Moving the Unit.....	6
Operation of the Control Lever Up and Down .....	7
Engaging the Pallet.....	7
<b>Section IV – Unit Maintenance</b> .....	<b>10</b>
Maintenance Checklist.....	10
Consumables.....	11
Trouble Shooting.....	11
<b>Section V - Technical Specification</b> .....	<b>12</b>
Assembly Overview .....	12
Bill of Materials .....	13
Assembly Overview – Control Box.....	14
Bill of Materials – Control Box .....	15
Assembly Overview – Steering.....	16
Bill of Materials – Steering .....	17
General Arrangement .....	18
<b>Section VI - Decommissioning the Unit</b> .....	<b>19</b>
Final De-commissioning and Disposal.....	19
Safety Tests to be performed at Intervals and after Unusual Incidents .....	19

# Section I – Correct Use and Application

## General

The unit described in the present operating instructions is designed for lifting, lowering and transporting load units. It must be used, operated and serviced in accordance with the present instructions. Any other type of use is beyond the scope of application and can result in damage to personnel, the unit or property.

## Correct Application

### NOTE:

The maximum load must not be exceeded.  
The load must be lifted by the attachment provided by the manufacturer.  
Correct applications of this unit are as follows:

- Lifting and lowering of loads
- Transporting lowered loads
- Maximum operational speed 4km/h
- Do not travel with a raised load (>500mm)
- Do not carry or lift passengers
- Do not negotiate on inclines

## Approved Application Conditions

- Operation in industrial and commercial environments
- Permissible temperature range 5°C to 40°C
- Maximum operational relative humidity of 50%
- Operation only on secure, level surfaces with sufficient capacity
- Operation only on routes that are visible and approved by the proprietor

## Proprietor Responsibilities

For the purposes of the present operating instructions the "proprietor" is defined as any natural or legal person who either uses the unit himself, or on whose behalf it is used. In special cases (e.g. leasing or renting) the proprietor is considered the person who, in accordance with existing contractual agreements between the owner and user of the unit, is charged with operational duties. The proprietor must ensure that the unit is used only for the purpose for which it is intended and that there is no danger to life and limb of the user and third parties. Furthermore, accident prevention regulations, safety regulations and operating, servicing and repair guidelines must be followed. The proprietor must ensure that all users have read and understood these operating instructions.

### NOTE:

Failure to comply with the operating instructions shall invalidate the warranty. The same applies if improper work is carried out on the unit by the customer or third parties without the permission of the manufacturer.

## Adding Attachments and/or Accessories

The mounting or installation of additional equipment which affects or enhances the performance of the unit requires written permission of the manufacturer. Local authority approval may also need to be obtained. Local authority approval does not however constitute the manufacturer's approval.

## Safety Regulations for the Operation of the Unit

### Driver authorisation

The unit may only be used by suitably trained personnel, who have demonstrated to the proprietor, or his representative that they can drive and handle the loads and have been authorised to operate the unit by the proprietor or his representative.

### Driver's rights, obligations and responsibilities

The driver must be informed of his duties and responsibilities and be instructed in the operation of the unit and shall be familiar with the operating instructions. The driver shall be afforded all due rights. Safety shoes must be worn for pedestrian units.

### Unauthorised use of unit

The driver is responsible for the unit during the time it is in use. The driver must prevent unauthorised persons from driving or operating the unit. Do not carry passengers or lift other people.

### Damage and faults

The supervisor must be immediately informed of any damage or faults to the unit or attachment. Units which are unsafe for operation (e.g. wheel or brake problems) must not be used until they have been rectified.

### Repairs

The driver must not carry out any repairs or alterations to the unit without the necessary training and authorisation to do so. The driver must never disable or adjust safety mechanisms or switches.

### Hazardous area

#### WARNING! Risk of accidents / injury in the hazardous area of the unit.

The hazardous area is defined as the area in which a person is at risk due to unit movement, lifting operations, the handler (e.g. forks or attachments) or the load itself. This also includes areas which can be reached by falling loads or lowering operating equipment.

- Instruct unauthorised people to leave the hazardous area
- Give a warning signal with plenty of time for people to leave
- If unauthorised personnel are still within the hazardous area stop the unit immediately

### Safety devices and warning labels

Safety devices, warning signs and warning instructions in the present operating instructions must be strictly observed.

### Travel routes and work areas

Only use lanes and routes specifically designated for unit traffic. Unauthorised third parties must stay away from work areas. Loads must only be stored in places specifically designated for this purpose. The unit must only be operated in work areas with sufficient lighting to avoid danger to personnel and materials. Additional equipment is necessary to operate the unit in areas of insufficient lighting.

### DANGER!

Do not exceed the permissible surface and spot load limits on the travel routes. At blind spots get a second person to assist.

### Travel conduct

The driver must adapt the travel speed to local conditions. The unit must be driven at slow speed when negotiating bends or narrow passageways, when passing through swing doors and at blind spots. Abrupt stopping (except in emergencies), rapid U turns and overtaking at dangerous or blind spots are not permitted. Do not lean out or reach beyond the working and operating area.

### Travel visibility

The driver must look in the direction of travel and must always have a clear view of the route ahead. Loads that affect visibility must have a second person walk alongside the unit as a lookout to observe the travel route while maintaining eye contact with the driver. Proceed only at

walking pace and with particular care.

#### **Type of loads to be carried**

The operator must make sure that the load is in a satisfactory condition. Loads must always be positioned safely and carefully. Use suitable precautions to prevent parts of the load from tipping or falling down. Prevent liquid loads from sloshing out.

### **Unit Operation**

#### **WARNING!**

##### **Unsecured and incorrectly positioned loads can cause accidents**

Before lifting a load, the operator must make sure that it has been correctly positioned and does not exceed the unit's capacity.

- Instruct other people to move out of hazardous area of the unit. Stop working with the unit if people do not leave the hazardous area
- Only carry loads that have been correctly secured and positioned. Used suitable precautions to prevent parts of the load from tipping or falling down
- Damaged loads must not be transported
- Never exceed the maximum load capacity of the unit
- Never stand underneath a raised load handler
- Do not stand on the load handler
- Do not lift other people on the load handler

#### **WARNING!**

##### **Risk of accidents and damage to components**

All modifications to the unit, in particular safety mechanisms, are prohibited. The operating speeds of the unit must not be increased under any circumstances.

#### **NOTE:**

Only original spare parts have been certified by the manufacturer. To ensure safe and reliable operation of the unit, use only the manufacturer's spare parts.

### **Maintenance Safety Regulations**

#### **Maintenance Personnel**

The unit should only be serviced and repaired by a competent individual as selected by the company the equipment is intended for use with.

#### **Lifting and jacking up**

#### **WARNING!**

##### **Lifting and jacking up the unit safely**

In order to raise the unit, the lifting gear must only be secured to the points specially provided for this purpose. You may only work under a raised load handler if they have been secured with a sufficiently strong chain. In order to raise and jack up the unit safely, proceed as follows:

- Jack up the unit only on a level surface and prevent it from moving accidentally
- Always use a jack with sufficient capacity. When jacking up the unit, take appropriate measures to prevent it from slipping or tipping over (e.g. wedges, wooden blocks, etc.)
- In order to raise the unit, the lifting gear must only be secured to the points specially provided for this purpose (see "Transport and Commissioning")
- When jacking up the unit, take appropriate measures to prevent it from slipping or tipping over (e.g. wedges, wooden blocks)

#### **Consumables and Used parts**

#### **CAUTION!**

##### **Consumables and Used parts are an environmental hazard**

Used parts, oils and fuels must be disposed of in accordance with the relevant environmental protection regulations.

- Note the safety regulations when handling these materials

#### **Hydraulic hoses**

#### **WARNING!**

##### **Brittle hydraulic hose lines cause accidents**

The hoses must be replaced every six years. The manufacturer's customer service department is specially trained to carry out these operations.

- Comply with the safety regulations for hydraulic hose lines in accordance with BGR 237

#### **WARNING!**

##### **Hydraulic line leaks cause accidents**

Hydraulic oil can escape from leaky and faulty hydraulic lines.

- Report any defects immediately to your supervisor
- Tag out and decommission a faulty unit
- Only return the unit to service when you have identified and rectified the fault
- Spilled fluids must be removed of immediately with an appropriate bonding agent. The bonding agent / consumable mixture must be disposed of in accordance with regulations

#### **WARNING!**

##### **Hairline cracks in the hydraulic lines can cause injury and infection**

Pressurised hydraulic oil can penetrate the skin through fine holes or hairline cracks in hydraulic lines, causing severe injury.

- Call for a doctor immediately if you are injured
- Do not touch pressurised hydraulic lines
- Report any defects immediately to your supervisor
- Tag out and decommission a faulty unit
- Only return the unit to service when you have identified and rectified the fault
- Spilled fluids must be removed of immediately with an appropriate bonding agent. The bonding agent / consumable mixture must be disposed of in accordance with regulations

#### **Lift Chains**

#### **WARNING!**

##### **Incorrectly cleaned chains can cause accidents**

Lift chains are safety-critical parts. They must not contain any serious contamination. Lift chains and pivot pins must always be clean.

- Lift chains should only be cleaned with paraffin derivatives e.g. petroleum or diesel fuels
- Never clean chains with steam jet high pressure cleaners, cold or chemical cleaning agents
- Immediately after cleaning, dry the lift chain with compressed air and apply a chain spray

## Servicing and Inspection

Thorough and expert servicing is one of the most important requirements for the safe operation of the unit. Failure to perform regular servicing can lead to unit failure and poses a potential hazard to personnel and equipment.

### WARNING!

The application conditions of a unit have considerable impact on the wear of the service components.

## Lifting the Unit

### WARNING!

#### Improper lifting by crane can result in serious accidents

The use of unsuitable lifting gear can cause the unit to crash when being lifted by crane. Prevent the unit from striking other objects when it is being raised, and avoid any involuntary movements. If necessary secure the unit with guide ropes. The strap point on the mast is for loading the unit with lifting gear.

- The unit should only be handled by people who are trained in using lifting slings and tools
- Do not walk into or stand in a hazardous area
- Always use lifting gear with sufficient capacity
- Always attach the slings to the prescribed strap points and prevent them from slipping

### WARNING!

#### Accidental movement during transport

Improper fastening of the truck and mast during transport can result in serious accidents.

- Loading must be carried out by special trained staff in accordance with recommendations contained in Guidelines BS EN 12640:2001. In each case correct measurements must be made and appropriate safety measures adopted
- The unit must be securely fastened when transported on a lorry or trailer
- The lorry/trailer must have fastening rings
- Use wedges to prevent the unit from moving
- Use only tension belts or tie-down straps or with sufficient strength

The strap point on the mast is for loading the unit with crane lifting gear.

#### Lifting the Unit

##### Requirements

- Park the unit securely

##### Tools and Material Required

- Lifting gear

##### Procedure

- Secure Lifting slings to the strap point

The unit can now be lifted.

#### Securing the truck for transport

##### Tools and Material Required

- Tension belts/tie down straps

##### Procedure

- Move the unit onto the transporting truck
- Park the unit securely
- Strap the belts around the unit and tension them sufficiently, utilising the strap points on the mast

The unit can now be transported.

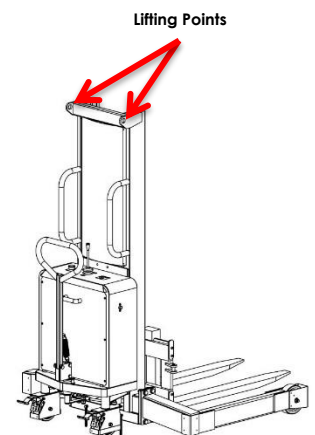

## Section II – Unit Description

The STP07-FAC01-Ex is a four-wheeled pedestrian stacker with stainless steel-clad forks. It is designed for use on level surfaces to lift and transport pallets of up to 1200mm x 1200mm in size with a maximum load of 1300kg. The unit is pneumatic hydraulic and is suitable for use in Zone 1 gas and dust areas.

With the pallet on the floor and forks suitably positioned, the unit can approach the open side of the pallet. The unit is then pushed forward until the forks are fully inserted inside the pallet. The pallet can then be lifted and transported to the desired location.

The unit incorporates enclosed, smooth geometry with rounded edges to ensure safe handling of the unit. The unit is fitted with a fully enclosed pump/ram unit which is operated from the rear of the unit to keep operator's limbs away from dangerous machinery movement.

**The Safe Working Load (SWL) of this unit is 1300kg.**

**This unit is designed for use on flat and level floors only.**

## Section III – Unit Operation

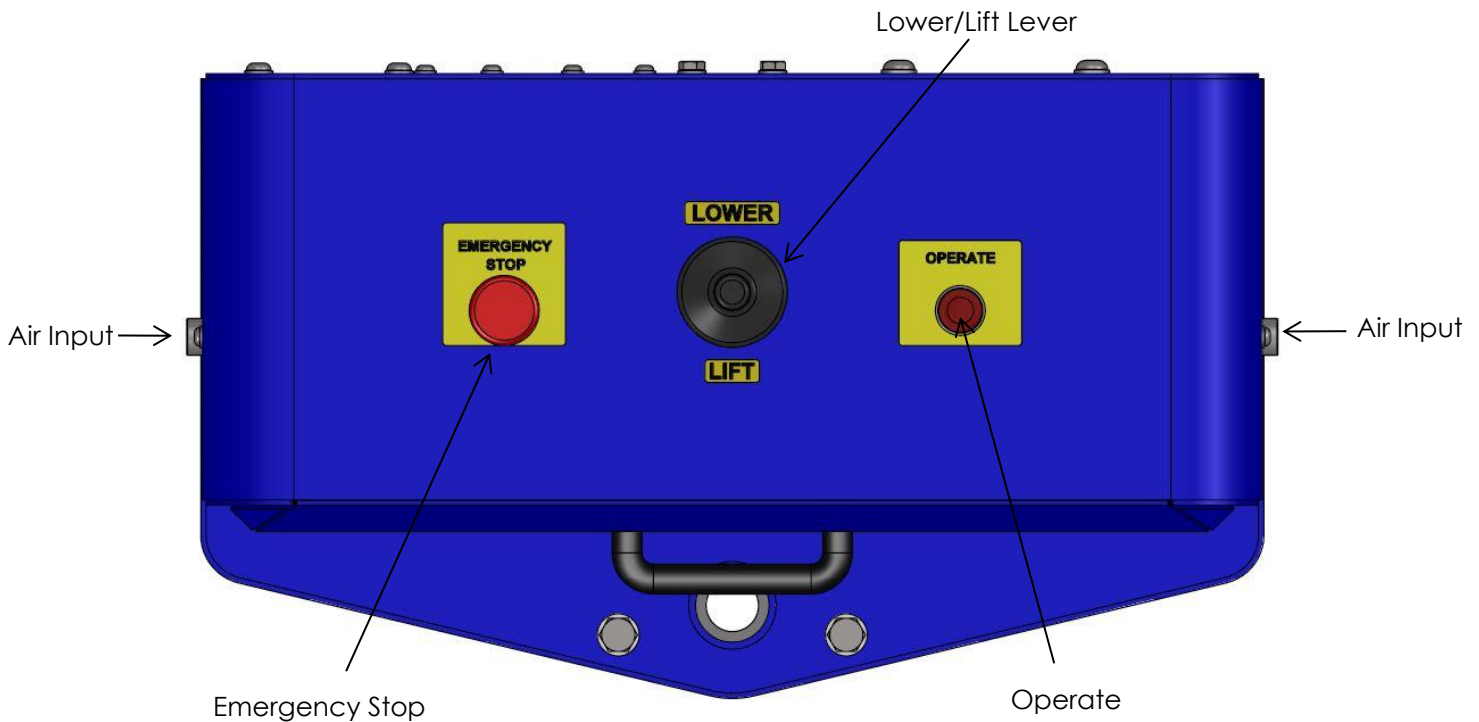

### **IMPORTANT**

Before using the STP07-FAC01-Ex operators must read and understand this instruction manual. Failure to observe the instructions in this manual will invalidate the warranty.

The maximum weight of pallet that the unit should be used to pick up is **1300kg**.

### Set Up

1. The STP07-FAC01-Ex requires a dry clean air supply, which should be connected to the unit via a flexible air hose fitted with a quick release coupling. The unit will operate with a maximum pressure of 9 bar.
2. The STP07-FAC01-Ex is now ready to use.

### Moving the Unit

#### *Requirements*

- If loaded, load correctly lifted.
- Load at correct height for transport.
- Good ground conditions.
- If loaded, 2 personnel available to manoeuvre the unit.

#### *Procedure*

1. Disengage the rear parking brakes.

2. The unit can then be manoeuvred to the desired location.
3. Steering is controlled from the rear of the stacker.
4. Travel at a constant speed.
5. Adapt your travel speed to the conditions of the route and the load you are transporting.
6. When finished manoeuvring the rear parking brakes should be engaged.

**IMPORTANT** – This unit is designed for use on flat and level floors only.

## Operation of the Control Lever Up and Down

### Requirements

- Pallet fully engaged with forks, see 'Engaging the Pallet'.
- Load undamaged and load does not exceed the unit's capacity.
- Air supply of maximum 9 Bar is connected.

### Procedure

1. To lift the carriage, press the operate button whilst pulling the lift/lower lever at the rear of the unit. As the lever is pulled the carriage will go up and when the lever is let go or returned to the middle position the carriage will stop and remain at the current height.
2. To lower the carriage, simply press the operate button and push the lever forward and the carriage will go down.
3. The control lever operates on a dead-man's principle for safety so when the lever is let go or returned to the middle position the carriage will stop and remain at the current height.
4. The unit also is fitted with an operate button so if the operator releases this button at any time then all functions will stop.
5. There is a red emergency stop button on top of the control panel. To stop all movement of the lift or lower functions press the button down. To re-set the button, turn clockwise.
6. The unit is safe even if the airline is disconnected during the operation of the unit. The load will simply stop at the attained height.
7. The unit requires air to be connected to operate any functions but the air supply may be disconnected to manoeuvre the unit.

## Engaging the Pallet

1. The pallet should be in front of the unit in the horizontal orientation.
2. The forks can be slid along the carriage to line up with the fork pockets on the pallet. Keep the forks equal distance from each end of the carriage.
3. With the forks lowered to a position where they can fit underneath the pallet, push the unit forward as far as possible so that the forks are fully inserted. Ensure that the forks are inserted to the full length of the pallet. Never attempt to lift a pallet if the forks aren't fully inserted.



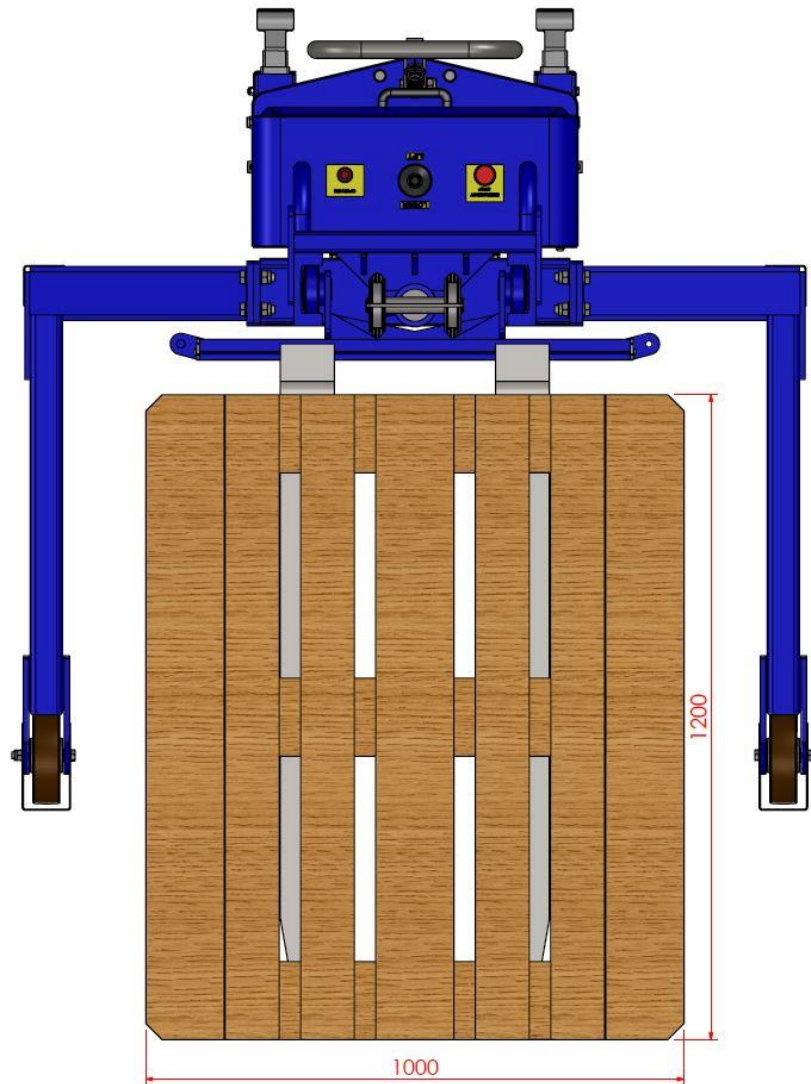

4. Once in position on the forks, as shown above, the pallet can be lifted using the Lift/Lower lever mounted on the control box.
5. Always travel with the pallet as low as practical.
6. Never attempt to lift a damaged pallet.

**IMPORTANT** - Check steps 1-6 have been completed correctly before you lift the pallet off the floor. If you are in any doubt then contact the STS Technical support line. +44 1736 851 050

**ISOLATE THE AIR SUPPLY WHEN NOT IN USE**

## Operations for Using the Ratchet and Strap (If Applicable)

1. To use the Ratchet and Strap first link the Hook around the Dee Shackle supplied with the unit. This should be attached to the carriage.
2. Next wrap the Strap around the item to be held to the Forks.
3. Open the Ratchet and thread the open end of the Strap through the Ratchet and pull through the slack.
4. Operate the Ratchet to tighten the strap until the item is securely held against the Forks of the unit. Ensure that the Strap enters straight and wraps evenly around the Ratchet.
5. To release the item, first ensure that it is supported then open the Ratchet as far as possible and pull the Strap away.

**ISOLATE THE AIR SUPPLY WHEN NOT IN USE**

## Section IV – Unit Maintenance

### Maintenance Checklist

The follow servicing checklist indicates the operations to be performed and the respective intervals to be observed. Maintenance intervals are defined as:

- W = Every 50 service hours, at least weekly
- A = Every 1000 service hours, at least annually
- = Standard maintenance interval

*During the run-in period – after approx. 100 service hours – the owner must check the wheel nuts/bolts and re-tighten if necessary.*

<b>Brakes</b>		<b>W</b>	<b>A</b>
1	Check rear park brakes. Adjust if necessary. They must be adjusted so that it is easy for the operator to release the brake with the toe of their boot.	●	●

<b>Travel</b>		<b>W</b>	<b>A</b>
1	Check wheels for wear and damage	●	●

<b>Hydraulic Operations</b>		<b>W</b>	<b>A</b>
1	Test hydraulic system (fully raise and lower carriage).	●	●
2	Check hydraulic oil and top up if necessary.	●	●
3	Check that hydraulic ports, hose and pipe lines are secure, check for leaks and damage.		●
4	Check cylinders and piston rods for damage and leaks, and make sure they are secure.		●
5	Check hydraulic tank for leaks.	●	●
6	Change oil every 2 years. Use Shell Tellus 22 or Equivalent.		●

<b>Chassis and Superstructure</b>		<b>W</b>	<b>A</b>
1	Check doors and/or covers.	●	●
2	Check labels are legible and complete.	●	●
3	Check mast guard for damage.	●	●
4	Check chassis and screw connections for damage.		●
5	Check the load chain and tension if necessary.		●
6	Visually inspect the mast bearings and check contact surface wear level.		●
7	Check lateral clearance of mast connections and carriage.		●
8	Inspect chain roller for wear.		●
9	Check for damage to painted surfaces, paint with approved touch up paint.		
10	If fitted with a ratchet strap, check for damage.	●	●

<b>Agreed Performance Level</b>		<b>W</b>	<b>A</b>
1	Carry out a test run with rated load, if necessary with customer specified load		●

**OPERATORS SHOULD REPORT ANY DEFECTS ON THE STP07-FAC01-Ex TO THE APPROPRIATE PERSON, IF IN ANY DOUBT OR YOU NEED REPLACEMENT PARTS PLEASE CONTACT THE STS TECHNICAL SUPPORT LINE.**

## Consumables

Bespoke Handling Equipment stackers are factory-equipped with Shell Tellus 32 oil for the hydraulic system. It is recommended to use as stated or an equivalent when replacing hydraulic oil.

## Trouble Shooting

When trying to locate a fault, proceed in the order shown in the table.

### NOTE:

Troubleshooting must only be performed by a suitably competent individual as decided by the company the equipment is intended for use with.

If, after carrying out the following remedial action, the unit cannot be restored to operation, contact the manufacturer's technical helpline. In order for customer services to react quickly and specifically to the fault, the following information is essential:

- Unit serial number
- Unit product name
- Description of error
- Current location / Company

### Load cannot be lifted

Possible Cause	Action
The load exceeds the SWL	Reduce mass of load
Hydraulic oil level too low	Check hydraulic oil level
Air pressure too low	Check air supply
Emergency stop operated	Reset emergency stop button
Operate button is not pressed	Press the operate button

### Load cannot be lowered

Possible Cause	Action
Emergency stop operated	Reset emergency stop button
Air pressure too low	Check air supply
Operate button is not pressed	Press the operate button

### Unit cannot be moved

Possible Cause	Action
Rear parking brakes are engaged	Release the rear parking brakes

## Section V - Technical Specification

### Assembly Overview

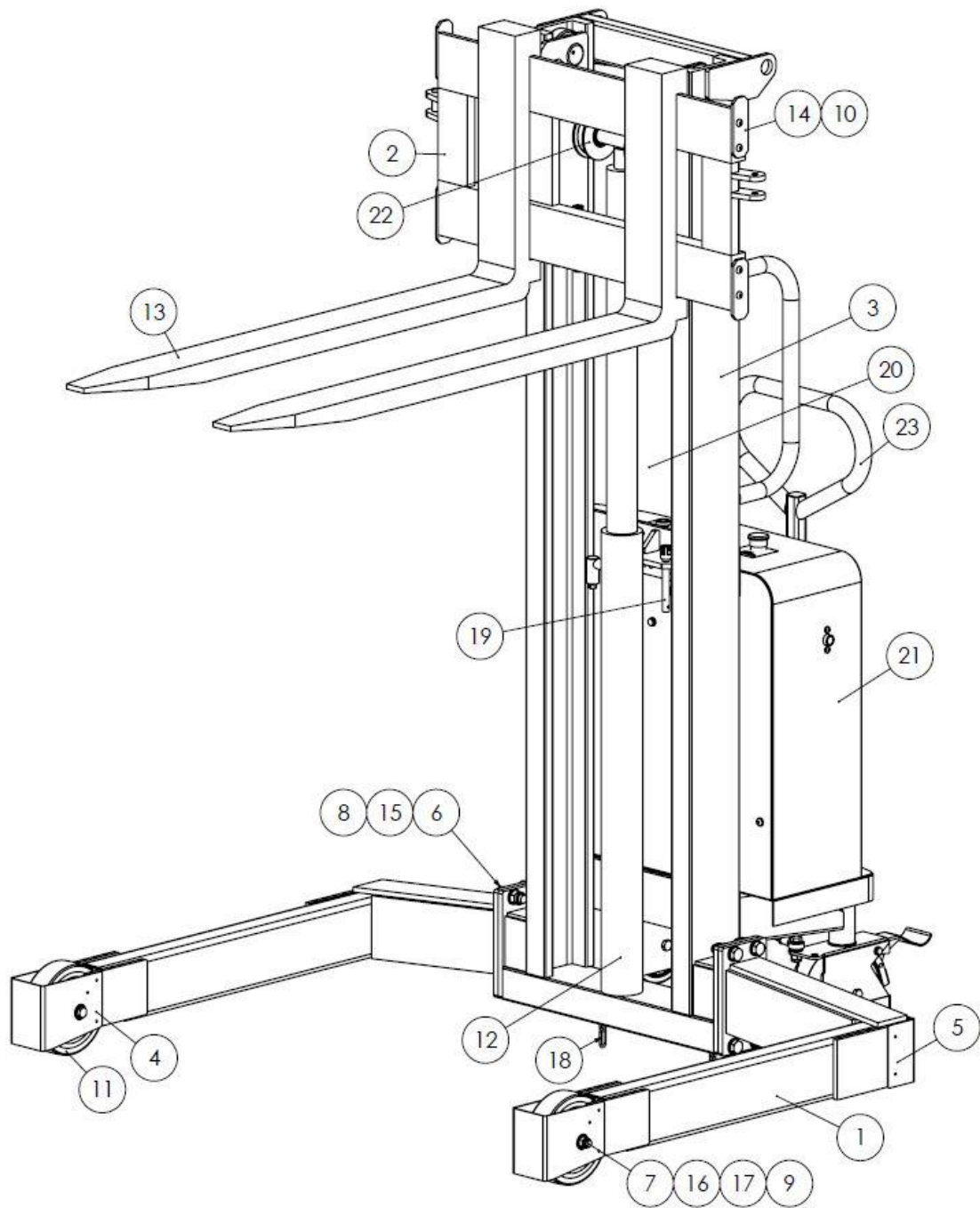

## Bill of Materials

Item No.	Description	Product Code	QTY.
1	1250 Straddle Legs 800 Long	011565	1
2	Adjustable Fork Carriage	011540	1
3	Heavy Duty Chassis For 1 Function Box	009055	1
4	Wheel Protection Ø180 Wheel	011538	2
5	Leg Corner ATEX Guard	011128	2
6	HEX BOLT - M16 X 55 - BZP	001072	8
7	HEX BOLT - M12 X 110 - BZP	001072	2
8	NYLOC NUT - M16P - BZP	001423	8
9	NYLOC NUT - M12P - BZP	001423	2
10	M8 x 20 Button Head Screw	002595	8
11	Ø180 - TW50 - HW60 - Ø20 - PU / CAST IRON - 900kg	011573	2
12	710mm Stroke Lift Ram	011549	1
13	FORKS 2A-10040-1150	001310	1
14	Fork End Stop	009321	4
15	Washer ISO 7091 - 16	001117	16
16	Washer ISO 7091 - 12	001117	4
17	OD20-ID12.2-L20 SS Flanged Wheel Bush	003075	4
18	4 Link Earthing Chain	004568	2
19	130mm Zinc Coated Clevis Bolt For LL10-44-Z	001602	4
20	ATEX Rated Polycarbonate Stacker Guard	011550	1
21	1 Function Pneumatic Control Box with GX20 pump	001321	1
22	Chain Wheel Assembly	001660	1
23	Stacker Ackermann Steering Assembly (Anti-Static Wheel) (M/S)	011403	1

## Assembly Overview – Control Box

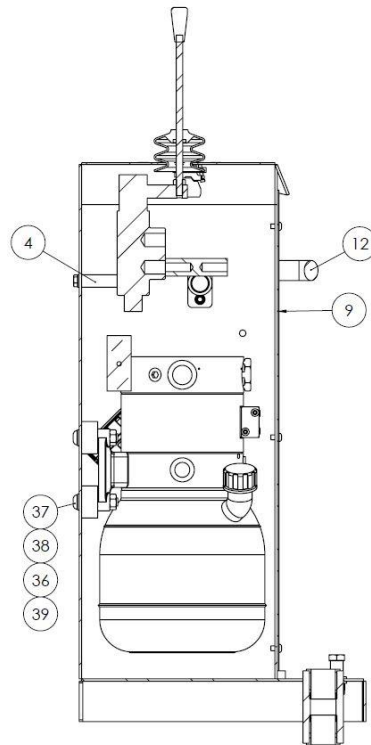
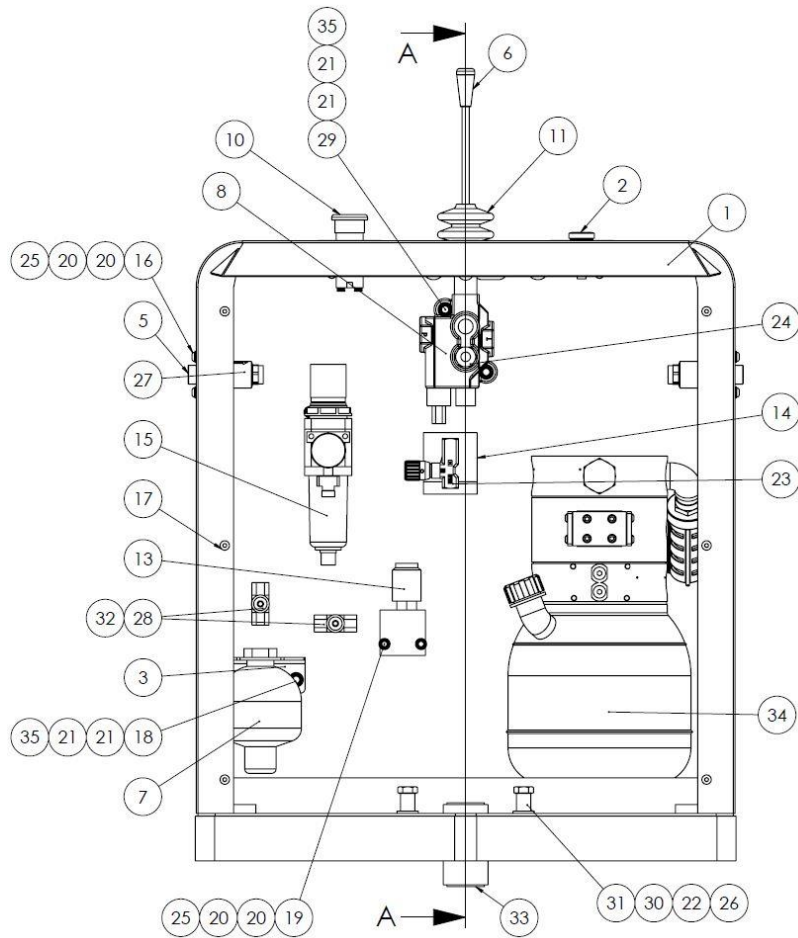

SECTION A-A

## Bill of Materials – Control Box

Item No.	Description	Product Code	QTY.
1	Single Function Pneumatic Control Box	001313	1
2	Pneumatic Push Button	004844	1
3	Accumulator Mount	001006	1
4	5/8" OD 1.5 Thick Pipe 44mm Long	001679	2
5	Air Inlet Bracket	002187	2
6	Standard Handle for Bucher Valve	002044	1
7	0.32L 40 Bar Hydraulic Accumulator	001244	1
8	Single Spool Closed Centre Monoblock Valve	001314	1
9	Std STE/P01 Control Box Cover	002380	1
10	Pneumax Emergency Stop	001462	1
11	Silicone / Rubber Lever Bellow	002184	1
12	Nylon Control Box Cover Handle	002229	1
13	Hydraulic 2 Port Poppet Valve	003176	1
14	Pneumatic Shut Off Valve (Pneumax)	003497	1
15	Pneumatic Filter Regulator Assembly	001317	1
16	M6 x 20 Button Head Screw	002595	6
17	M6 x 10 Button Head Screw	002595	6
18	M8 x 20 Button Head Screw	002595	2
19	M6 x 50 Button Head Screw	002595	2
20	Washer ISO 7091 - 6	001117	16
21	Washer ISO 7091 - 8	001117	8
22	Washer ISO 7091 - 12	001117	4
23	1/4" 1 Way Variable Flow Restrictor	003493	1
24	Pressure Compensated Flow Restriction Valve	003495	1
25	Nyloc Nut - M6P - BZP	001423	8
26	Nyloc Nut - M12P - BZP	001423	2
27	3/8" Brass Check Valve	010880	2
28	Test Port	011247	2
29	Hex Bolt - M8 X 80 - BZP	001072	2
30	Hex Set Screw - M12 X 45 - BZP	001072	2
31	Telescopic Channel Top Bearing Spacers	001868	2
32	1/4 Inch Fixed Equal Tee	011360	2
33	Iglidur H ATEX Flange Bearing	009223	2
34	Heypac GX40 Hydraulic Pump Assembly	004840	1
35	Nyloc Nut - M8P - BZP	001423	4
36	M10 Stud Mount Male to Female	011551	4
37	M10 x 15 Button Head Screw	002595	4
38	Washer ISO 7091 - 10	001117	4
39	Metric Nut (Configurable)	001280	4



## Assembly Overview – Steering

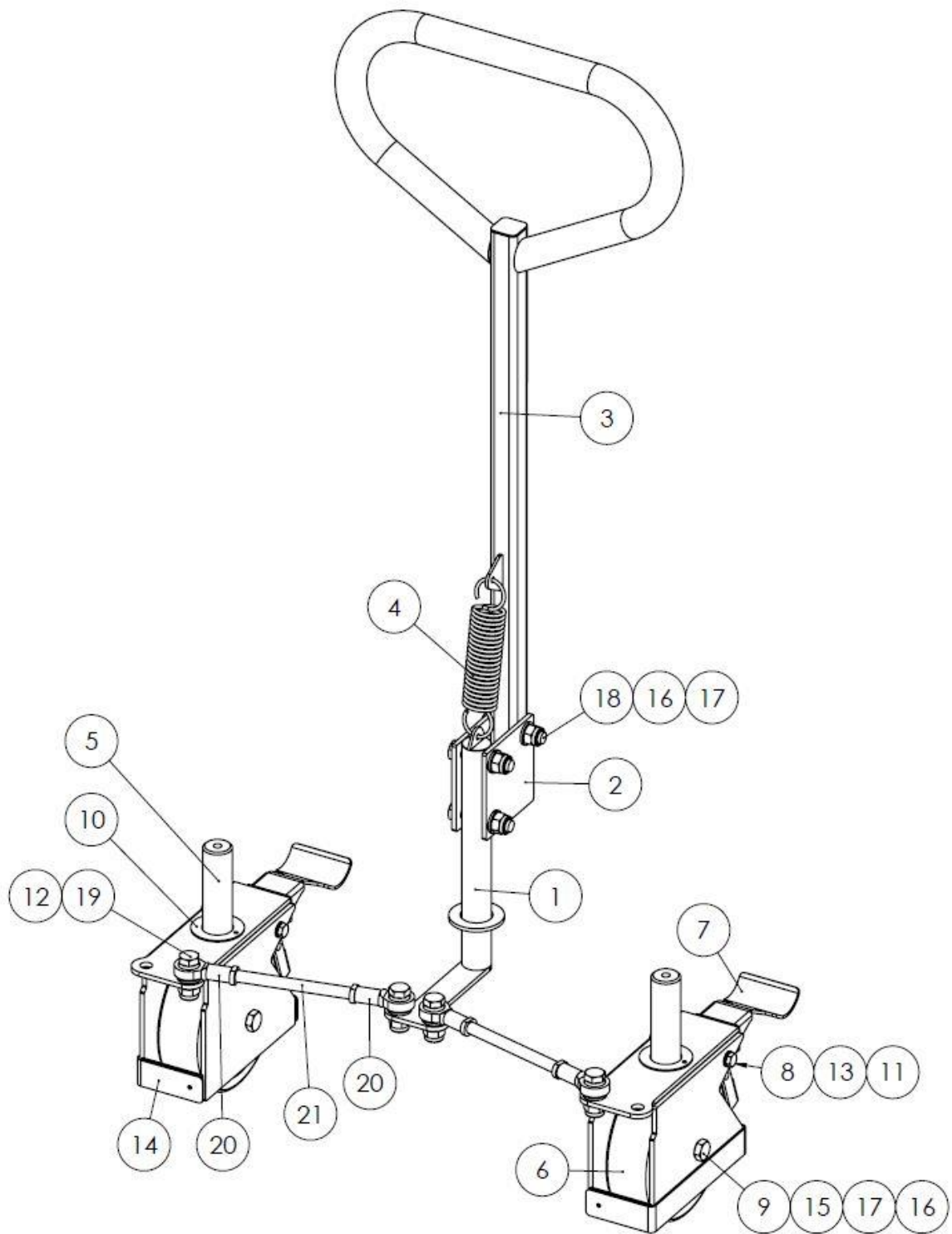

## Bill of Materials – Steering

Item No.	Description	Product Code	QTY.
1	Steering Shaft	001165	1
2	Steering Clevis	001164	1
3	Manual Drag Handle	001163	1
4	Zinc Plated Spring for Stacker Steering Handle	001162	1
5	160mm Wheel Chassis (M/S)	001844	2
6	160mm Grey PU/Alu Centre Wheel (Anti-Static)	002289	2
7	WHS01 Brake Assembly	001161	2
8	Hex Bolt - M8 X 90 - BZP	001072	2
9	Hex Bolt - M12 X 90 - BZP	001072	2
10	G Thrust Washers	002765	2
11	Nyloc Nut - M8P - BZP	001423	2
12	Nyloc Nut - M12P - BZP	001423	4
13	Washer ISO 7091 - 8	001117	4
14	Rear Wheel ATEX Guard WHS01	011136	2
15	OD20-ID12.2-L22 Zinc Flanged Wheel Bush	009049	4
16	Nyloc Nut - M12P - A2	001423	5
17	Washer ISO 7091 - 12	001117	11
18	Hex Bolt - M12 X 60 - BZP	001072	3
19	Hex Set Screw - M12 X 40 - BZP	001072	4
20	M12 Steel Rod End	001166	4
21	12mm Threaded Bar x 146 long	009060	2

## General Arrangement

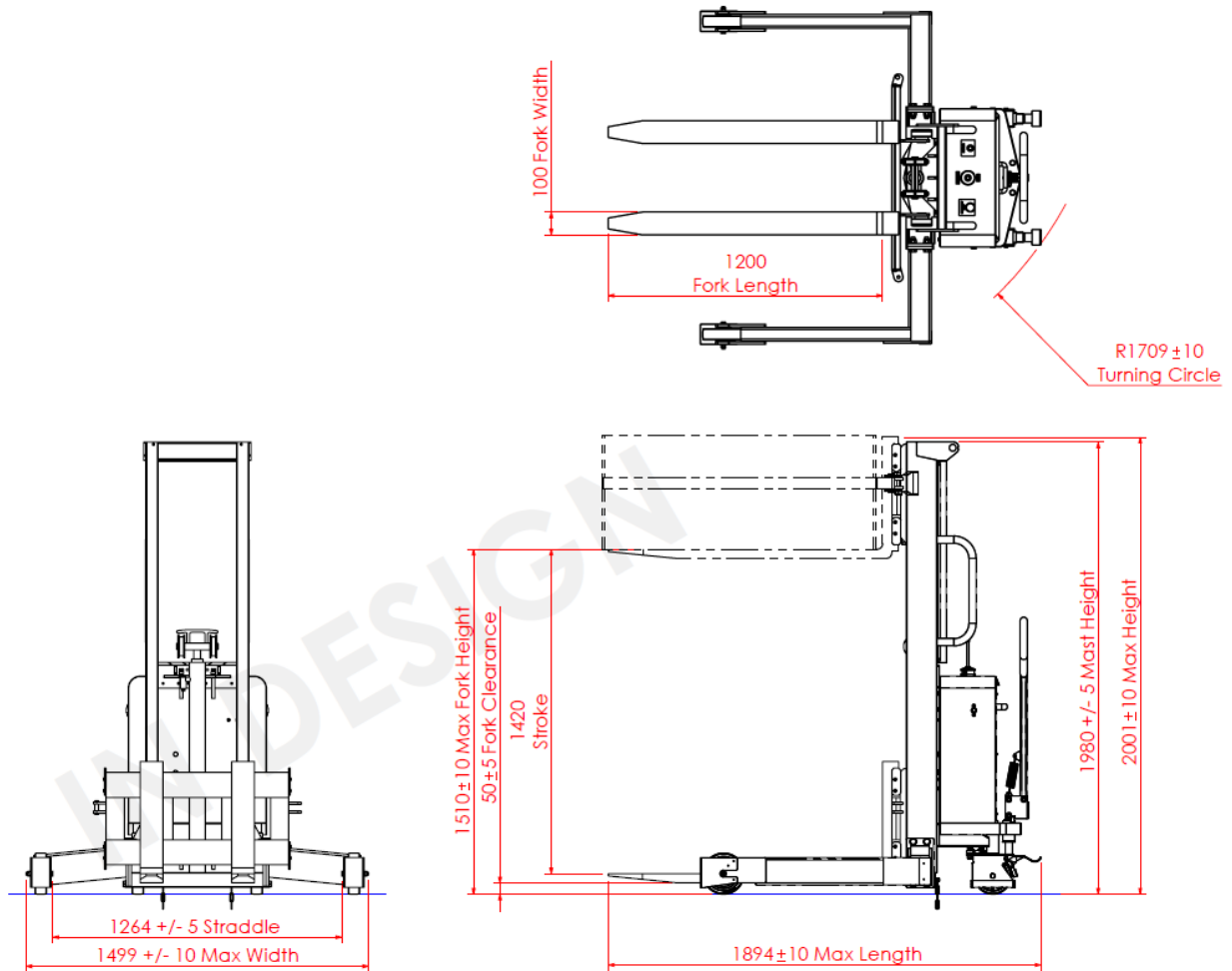

**SWL.** 1300kg

**Net Mass.** 535kg

**Max Noise Level.** 79dBA

## Section VI - Decommissioning the Unit

If the unit is to be out of service for more than a month, e.g. for commercial reasons, it must be stored in a frost-free and dry room. All necessary measures must be taken before, during and after decommissioning as described hereafter.

### Prior to decommissioning

- Thoroughly clean the unit
- Test the brakes
- Check the hydraulic oil and replenish if necessary
- Apply a thin layer of oil or grease to any non-painted mechanical components

### Final De-commissioning and Disposal

Final de-commissioning or disposal of the unit must be performed in accordance with the regulations of the country of use. In particular, regulations governing the disposal of batteries, fuels and electronic and electrical systems must be observed.

The truck must only be disassembled by trained personnel.

### Safety Tests to be performed at Intervals and after Unusual Incidents

Perform a safety check in accordance with national regulations. The unit must be inspected at least annually or after any unusual event by a qualified inspector. The inspector shall assess the condition of the unit from purely a safety viewpoint, without regard to operational or economic circumstances.

For further help contact the Bespoke Handling Equipment:

**Technical Support Line: 44 (0) 1736 851050**

In the interest of all concerned it is essential that equipment of our manufacture is used only for the purposes for which it has been designed and it must be used in accordance with the instructions which are supplied.