

# Operating Instructions

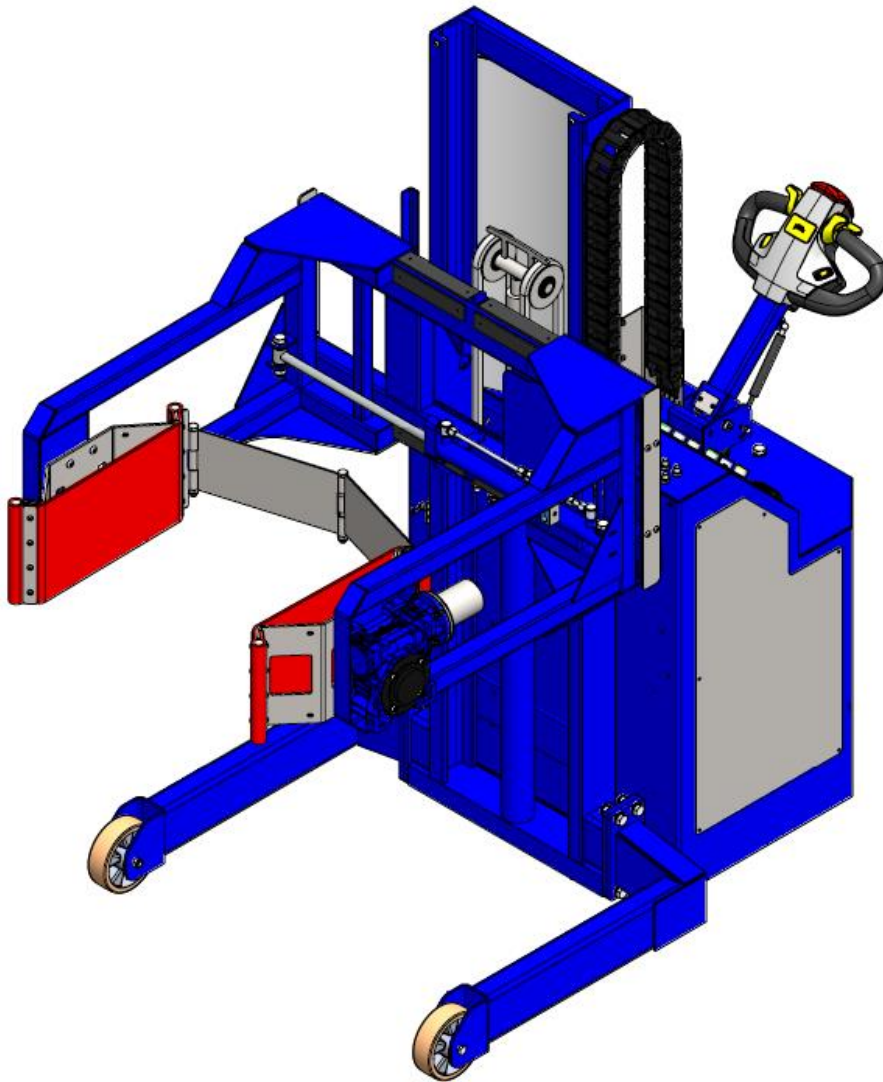

## STE05-RRH01

Power Drive Electric-Hydraulic Stacker with  
Powered Clamp and Drum Rotation

Bespoke Handling Equipment Ltd.  
Leedstown  
Hayle  
Cornwall  
United Kingdom  
TR27 6DS

E-mail: [sales@sts-trolleys.co.uk](mailto:sales@sts-trolleys.co.uk)  
Tel: +44 (0)1736 851050  
Website: [www.sts-trolleys.co.uk](http://www.sts-trolleys.co.uk)

<b>Section I – Correct Use and Application</b> .....	<b>3</b>
General .....	3
Foreseeable Misuse of the Unit.....	3
Approved Application Conditions.....	3
Proprietor Responsibilities .....	4
Adding Attachments and/or Accessories.....	4
Safety Regulations for the Operation of the Unit .....	4
Consumables and Parts .....	6
Ex Certified Units (if applicable) .....	6
Lifting the Unit .....	7
Unit Overview.....	8
Permitted Operating Zones .....	9
<b>Section II – Unit Description</b> .....	<b>10</b>
<b>Section III – Unit Operation</b> .....	<b>11</b>
Pre-start Inspections .....	11
Charging Operation.....	12
Unit Controls.....	12
Moving the Unit.....	13
Operating the Lift and Lower Functions .....	14
Clamping a Drum.....	15
Clamping Pressures .....	16
Drum Rotating Head .....	17
Fitting the Drum Catch and Gates .....	18
Tipping a Drum .....	19
Maximum Offset Load for Rotating a Load.....	19
<b>Section IV – Unit Maintenance, Troubleshooting and Consumables</b> .....	<b>20</b>
Maintenance Checklist.....	20
Troubleshooting .....	22
Consumables.....	24
Oil Replacement.....	24
Clamping Pad Replacement .....	25
Polycarbonate Guarding Replacement .....	26
Battery Replacement .....	27
Safety Regulations Governing the Handling of Lead-Acid Batteries.....	28
Battery Charging Safety .....	29
Wheel Replacement .....	30
<b>Section V - Technical Specification</b> .....	<b>31</b>
General Arrangement .....	31
<b>Section VI - Decommissioning the Unit</b> .....	<b>32</b>
Prior to Decommissioning.....	32

Final Decommissioning and Disposal .....	32
Recommissioning .....	32
Safety Tests to be Performed at Intervals and After Unusual Incidents. ....	32

## Section I – Correct Use and Application

Only operation manuals written in English are the original instructions, versions provided in any other language then become a translation of the original instructions.

### General

The unit described in the present operating instructions must be used, operated and serviced in accordance with the present instructions. Any other type of use is beyond the scope of application and can result in damage or injury to personnel, the unit or property. The unit described in the present operating instructions complies with BS EN ISO 17050-1:2010 and the EC Machinery Directive 2006/42/EC.

### Foreseeable Misuse of the Unit

Personnel must take care when operating the unit. The following actions must be adhered to:

- The maximum safe working load (SWL) must not be exceeded.
- Do not travel with a raised load 500mm above the ground unless necessary.
- When manoeuvring the unit, do not exceed a speed of 1m/s (3.6km/h).
- When manoeuvring a raised load above 500mm, do not exceed a speed of 0.1m/s (0.36km/h).
- If applicable, do not over lower the head of the unit onto a platform, such as a mezzanine floor.
- Do not carry or lift other personnel.
- Do not stand or ride on the unit.
- Loads must be undamaged.
- Do not negotiate inclines unless otherwise stated.
- Do not stand underneath a raised load or within the confines of the unit during operation.
- The load must be lifted and/or mixed by the attachment provided.
- Do not alter the unit specification from original supply.
- Do not disable, remove or adjust safety mechanisms or switches.
- Observe all instruction decals applied to the unit.
- Do not leave the unit in direct sunlight.
- The manufacturer shall not be held liable in case of faults or accidents due to negligence, incapacity, installation by unqualified personnel or improper use.

### Approved Application Conditions

- Operation in dry industrial and commercial environments.
- Permissible temperature range 5°C to 40°C.
- Lighting of at least 300 Lux.
- Altitudes not exceeding 2000m.
- Operation only on secure, level surfaces with sufficient capacity.
- Operation only on routes that are visible and approved by the proprietor.
- Operation in accordance with guidance stated within the operating instructions.
- The unit must be maintained in accordance with the maintenance schedule stated within the operating instructions.
- Appropriate personal protective equipment, PPE, must be worn at all times.

## Proprietor Responsibilities

For the purposes of the present operating instructions the “proprietor” is defined as any natural or legal person who either uses the unit themselves, or on whose behalf it is used. In special cases (e.g. leasing or renting) the proprietor is considered the person who, in accordance with existing contractual agreements between the owner and user of the unit, is charged with operational duties. The proprietor must ensure that the unit is used only for the purpose for which it is intended and that there is no danger to life or limb of the user and third parties. Furthermore, accident prevention regulations, safety regulations and operating, maintenance and repair guidelines must be followed. The proprietor must ensure that all users have read and understood these operating instructions. The proprietor must perform an onsite risk assessment before the unit is put in to service.

### **IMPORTANT**

Failure to comply with the operating instructions shall invalidate the warranty. The same applies if improper work is carried out on the unit by the proprietor or third parties without the permission of the manufacturer.

## Adding Attachments and/or Accessories

The mounting or installation of additional equipment which affects or enhances the performance of the unit requires written permission of the manufacturer. Local authority approval may also need to be obtained. Local authority approval does not however constitute the manufacturer’s approval. An onsite risk assessment must then be carried out.

**WARNING - ANY UNAUTHORISED MODIFICATIONS OR ADDITIONS TO THE UNIT SHALL INVALIDATE THE WARRANTY AND STS SHALL NOT BE LIABLE.**

## Safety Regulations for the Operation of the Unit

### **Operator authorisation**

The unit may only be used by suitably trained personnel, who have demonstrated to the proprietor, or their representative that they can operate the unit safely and in accordance with the operating instructions.

### **Operator’s rights, obligations and responsibilities**

The operator must be informed of their duties and responsibilities and be instructed in the operation of the unit and shall be familiar with the operating instructions. Operators must be provided the appropriate PPE as mentioned in the ‘Approved Application Conditions’ section of this manual.

### **Unauthorised use of unit**

The operator is responsible for the unit during the time it is in use. The operator must prevent unauthorised persons from operating the unit.

### **Damage and faults**

The proprietor must be immediately informed of any damage or faults to the unit or attachment. Units which are unsafe for operation must be quarantined until faults have been rectified and the unit deemed safe for operation.

### **Servicing and repairs**

All unit parts and consumables are available from STS. The unit must be fitted with original STS parts and consumables unless otherwise stated. Any deviation from non-original parts and consumables may result in injury to personnel or damage to the unit and will invalidate the warranty. The operator must never disable, remove or adjust safety mechanisms or switches. The unit should only be serviced and repaired by a competent individual as selected by the company the equipment is intended for use with.

### **Safety devices and warning decals**

Safety devices, warning decals and warning instructions in the operating instructions and on the unit must be strictly observed.

### **Travel routes and operational areas**

Only use lanes and routes specifically designated for unit traffic. Unauthorised third parties must stay away from operational areas. The unit must only be operated in operational areas with sufficient lighting to avoid damage or injury to personnel, the unit or property. Additional equipment is necessary to operate the unit in areas of insufficient lighting.

### **Hazardous area of the unit**

The hazardous area is defined as the area in which a person is at risk due to the unit itself or movement of the unit and/or load. This also includes areas which can be reached by falling loads. The operator must:

- Instruct unauthorised personnel to leave the hazardous area.
- Give a warning signal with plenty of time for personnel to leave.
- Stop all operations if unauthorised personnel are within or enter the hazardous area.

### **Travel conduct**

The operator must adapt the travel speed to local conditions. The unit must be driven at slow speed when negotiating bends or narrow passageways, when passing through swing doors and at blind spots. Abrupt stopping (except in emergencies), rapid U turns and overtaking at dangerous or blind spots are not permitted. When not in use, the equipment should be parked in a safe location with the brakes engaged.

### **Travel visibility**

The operator must look in the direction of travel and must always have a clear view of the route ahead. When transporting loads that affect visibility, a second person must safely assist the operator to observe the travel route.

### **Type of loads**

The operator must make sure that the load is in a satisfactory condition. Loads must always be positioned safely and carefully. Use suitable precautions to prevent parts of the load and/or their contents from falling or spilling.

### **Cleaning**

Cleaning of the unit depends on the environment that the unit is used in. It is recommended that the unit be cleaned daily if the unit comes into contact with aggressive substances such as chemicals, fertilizers, salt, etc. It is recommended to use detergent and a damp cloth to clean the body of the unit. Do not use flammable liquids to clean the unit. Do not clean the unit with pressurised water. If the unit is rated for Ex environments, the unit must be kept clean and dust free.

### **Personal protective equipment (PPE)**

PPE must be worn at all times. A minimum of safety shoes must be worn while operating the unit. Safety shoes, safety glasses, protective gloves, hearing protection and protective overalls are to be worn when carrying out servicing, repairs and maintenance. When operating overhead loads, a hard hat must be worn. End user health and safety procedures and best practices should be followed in addition to the above recommendations.

## **Consumables and Parts**

### **Environmental hazards**

Parts and oils must be disposed of in accordance with the relevant environmental protection regulations.

### **Hydraulic hoses (if applicable)**

Brittle hydraulic hose lines cause accidents. Hairline cracks in the hydraulic lines can cause injury and infection. The hydraulic hoses should only be serviced or replaced by a competent individual as selected by the company the equipment is intended for use with. It is the responsibility of the proprietor to maintain the hydraulic hoses.

### **Lift chains (if applicable)**

Incorrectly cleaned chains can cause accidents. Lift chains are safety-critical parts. They must not contain any serious contamination. Lift chains and pivot pins must always be clean. Never clean chains with high pressure steam jet cleaners, cold or chemical cleaning agents. It is recommended to clean the chains and pivot pins in an unloaded state with a citrus cleaner to remove dirt and grime followed by the application of a PTFE based industrial grade chain lubrication spray or food grade lubrication spray.

**NOTE:** For more consumable information refer to 'Section IV – Unit Maintenance, Troubleshooting and Consumables'.

## **Ex Certified Units (if applicable)**

### **Operational hazards**

Processing of liquids or suspensions (mixing or stirring, filling or draining) can give rise to ignition risks due to static electricity including the risk of propagating brush discharges. The processing of liquids or suspensions is the responsibility of the end user.

### **Environmental hazards**

Care should be taken by the end user to ensure collisions do not occur between the unit and its surrounding environments which may create a potential ignition source.

### **Earthing chains**

Ensure earthing chains are securely fitted and are in contact with the ground at all times, wheels should be kept clean and free from debris.

### **Electrically powered units**

Care should be taken by the end user to ensure any electrical cables to and/or from the unit are kept away from travel areas where they may become entangled, damaged or be a trip hazard. Electrical cables must be kept dry, clean and be routinely checked as stated in the maintenance procedures. Any cracked or damaged electrical cables must be reported immediately and the unit be put out of service until resolved.

## Lifting the Unit

### Lifting the unit safely

In order to raise the unit safely, including off a pallet, proceed as follows:

- The unit must be on a level surface to prevent it from moving accidentally.
- The lifting gear must only be secured to the points designated for this purpose.
- Always use lifting gear with sufficient capacity.
- The unit should only be handled by qualified personnel who are trained in using lifting slings and tools.
- Do not walk into or stand under a raised unit.
- If necessary, secure the unit with guide ropes to aid when lifting the unit.

### Jacking the unit safely

In order to jack up the unit safely, proceed as follows:

- The unit must be on a level surface to prevent it from moving accidentally.
- Always use a jack with sufficient capacity.
- The unit should only be handled by qualified personnel who are trained in using lifting slings and tools.
- When jacking up the unit, take appropriate measures to prevent it from moving, slipping or tipping over (e.g. wedges, wooden blocks, stops)

**WARNING - IMPROPER LIFTING CAN RESULT IN SERIOUS ACCIDENTS**

### Securing the unit for transport

In order to transport the unit safely, proceed as follows:

- The unit must be securely fastened when transported on a lorry/trailer.
- The lorry/trailer must have fastening rings.
- Use wedges to prevent the unit from moving.
- Use only tension belts or tie-down straps with sufficient strength.

**WARNING - IMPROPER FASTENING OF THE UNIT DURING TRANSPORT CAN RESULT IN SERIOUS ACCIDENTS**

### IMPORTANT

After use, remove supplied lifting strop(s) and/or dee shackles and dispose.

## Unit Overview

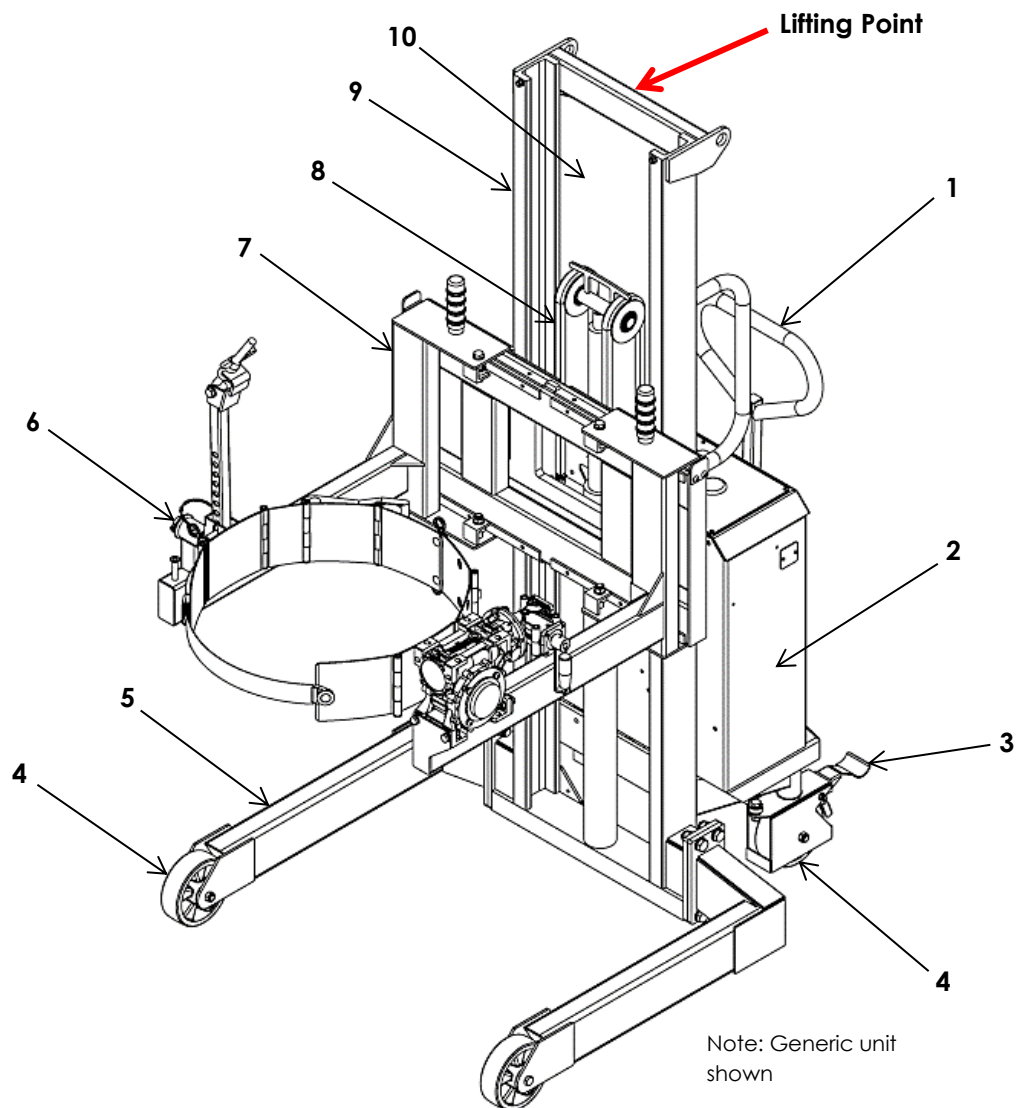

No.	Function
1	Steering
2	Control Box
3	Brakes
4	Wheels
5	Legs
6	Clamping Band
7	Head
8	Lifting Chains
9	Chassis
10	Polycarbonat Guarding

## Permitted Operating Zones

The unit is designed to be used by a single operator from the rear of the unit, unless otherwise stated. All other personnel in the area where the unit is in operation must remain clear of the unit, behind the unit or within area 1 shown below. Area 1 is classed as the safe working area.

Certain functions of the unit require the operator to work within area 2, the operator working within area 2 must be aware of the unit's functions and movements along with their potential trap points.

If the unit is fitted with a manual rotation handle, head controls or fitted with a pendant controller, the operator must remain within the areas 1 and 2 whilst operating the unit.

If applicable, the unit power must be isolated when accessing the front of the unit.

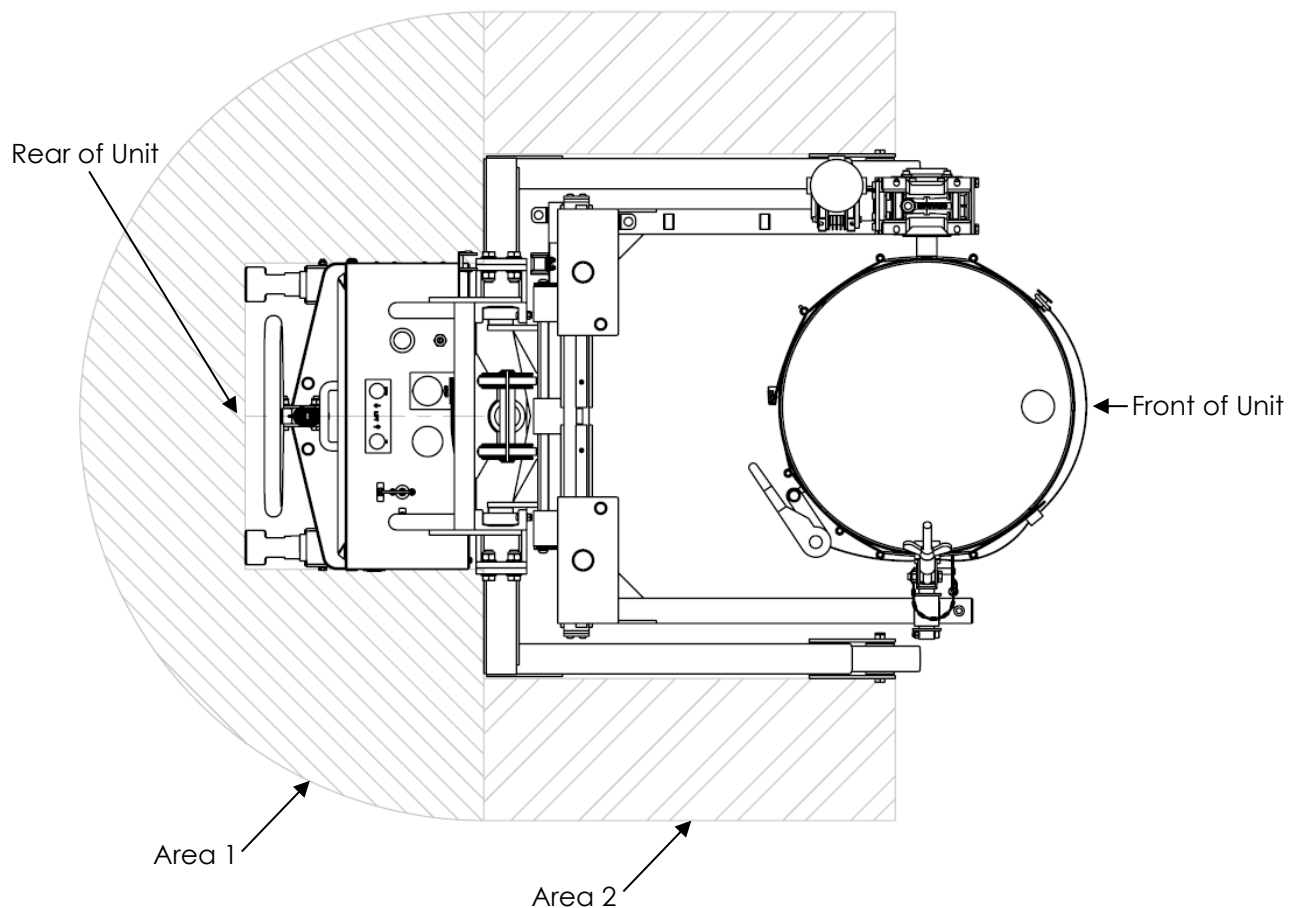

**WARNING - DO NOT STAND UNDERNEATH A RAISED LOAD, WITHIN THE CONFINES OF THE UNIT OR IN FRONT OF THE UNIT DURING OPERATION.**

## Section II – Unit Description

The STE05-RRH01 is a five-wheeled power-driven stacker with lifting, drum clamping and rotate functions. The unit is electric-hydraulic powered.

It is designed for use on level surfaces for use with drums ranging from 50 - 220 litres, steel or plastic drums with a diameter of between 250mm - 620mm.

The drum should be stood vertical; the unit can then approach the drum with the drum pads opened to their maximum width, and straddle either side. In the case of units with front gates fitted, the operator may have to lower the head over the drum. The operator then clamps the drum using the rear mounted controls until secure. The drum can then be lifted, transported and rotated.

The unit incorporates enclosed, smooth geometry with rounded edges to ensure safe handling of the unit. The unit is fitted with a fully enclosed ram, which is operated from the rear of the unit to keep operator's limbs away from dangerous machinery movement.

**THE SAFE WORKING LOAD (SWL) OF THIS UNIT IS 300KG**

**THIS UNIT IS DESIGNED FOR USE ON FLAT AND LEVEL FLOORS ONLY**

## Section III – Unit Operation

### **IMPORTANT**

Before using this unit, operators must read and understand this instruction manual. Failure to observe the instructions in this manual will invalidate the warranty.

**NOTE:** Personal Protective Equipment (PPE) must be worn at all times, see 'Section I – Correct Use and Application' for more information.

### Pre-start Inspections

#### Procedure

- Check the whole of the outside of the unit for signs of damage and leaks. Any damaged hoses must be replaced immediately.
- Check the unit for visible signs of damage such as cracks, bent or severely worn parts.
- Check all wheels for damage.
- Check that the markings and labels are present, clean and legible.
- Check the tiller handle is restored to its normal position.
- Ensure battery is fully charged (if applicable).
- Test the function of the emergency stop.
- Test the tiller horn (if applicable).
- Test brakes, adjust if necessary. (not applicable to powerdrive units)
- Check doors and/or covers for damage.
- Check the mast guarding for damage.
- Inspect the clamping mechanism for wear and damage.
- If applicable, check all Ex features:
  - Earthing chains are in contact with the ground.
  - Check wheels for dirt and grime, clean if required.
  - Check and clean, if required, the clamping pads on the head of the unit.
  - Check unit for any damaged painted surfaces, touch up, if necessary, with an approved touch up paint (see consumables).
  - Check stainless-steel guards for damage.

**OPERATORS SHOULD REPORT ANY DEFECTS ON THE UNIT TO THE APPROPRIATE PERSON. IF IN ANY DOUBT, OR SHOULD REPLACEMENT PARTS BE NEEDED, PLEASE CONTACT THE STS TECHNICAL SUPPORT LINE.**

## Charging Operation

### Requirements

- Park the unit securely close to a 230V charging outlet.

### Procedure

- Ensure unit is turned off.
- Plug the charging cable into the socket on the control box.

## Unit Controls

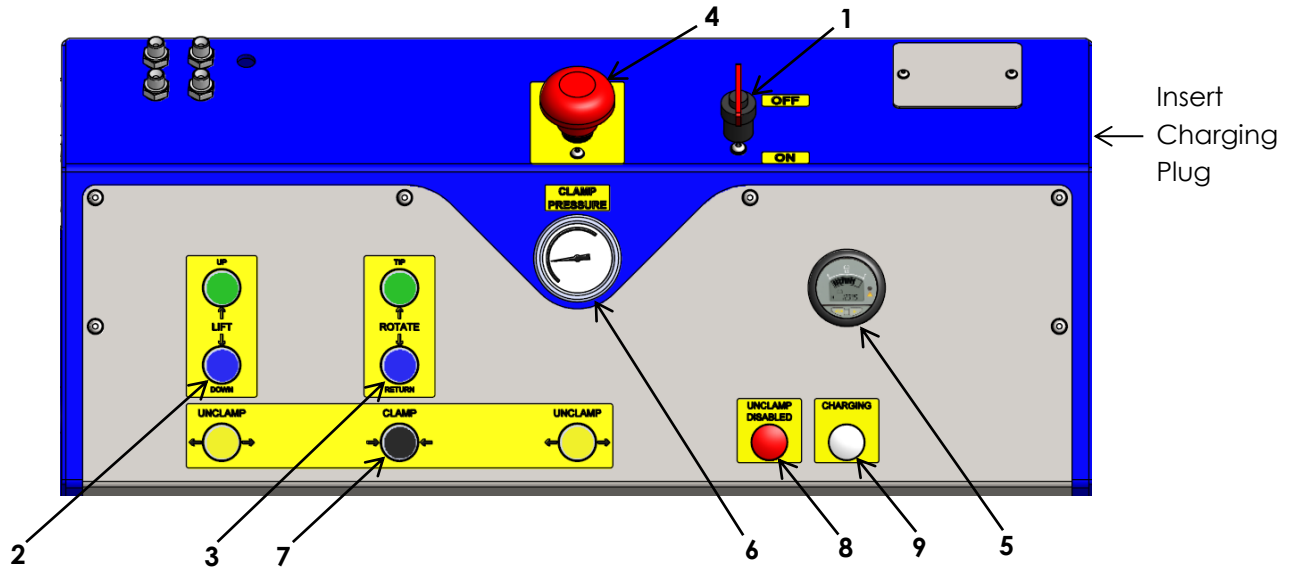

No.	Function
1	On/Off Isolator Switch
2	Lift/Lower Buttons
3	Rotate Buttons
4	Emergency Stop Button
5	Battery Condition Meter
6	Clamping Pressure
7	Clamp/Unclamp Buttons
8	Unclamping Disabled Warning Light
9	Charging Light

**NOTE:** The battery condition meter only measures voltage in a no-load situation. Under load the battery condition reading may differ. This means it can only be used as a guide to the battery status. It is possible that the unit will stop working before the battery condition meter reads 0%. For this reason, it is a good practice to keep the unit fully charged at all times when possible. Do not allow the batteries to be left in a discharged state as permanent damage can be caused to the batteries.

The unit is supplied with the following batteries as standard:

Unit Voltage	Battery Type	Capacity	Weight
24V	12V Exide ER650 Battery 349x175x290mm (LxWxH)	142Ah	2 x 35kg

## Moving the Unit

### Requirements

- If loaded, the load must not exceed the unit's capacity.
- If loaded, load undamaged.
- Load at correct height for transport (< 500mm).
- Flat and level ground conditions.
- Power key switched to 'On'.
- Batteries charged.

### Procedure

- Pull back on the tiller handle to activate the drive, use the throttle to control forwards and backwards movement. The further the throttle is rotated, the faster the unit will go. If the operator releases the throttle the unit will stop. If the tiller is moved into the vertical or horizontal position the drive is disabled; this is a safety feature.
- The unit can then be manoeuvred to the desired location.
- Travel at a constant speed.
- Adapt your travel speed to the conditions of the route and the load you are transporting.
- Always transport loads at as low a height as possible to retain the stability of the unit.

**THIS UNIT IS DESIGNED FOR USE ON FLAT AND LEVEL FLOOR ONLY**



## Operating the Lift and Lower Functions

### Requirements

- Good ground conditions.
- If loaded, the load must not exceed the unit's capacity.
- If loaded, load undamaged.
- If loaded, load clamped correctly.
- Batteries charged.

### Procedure

- The lift and lower buttons on the unit move the carriage up and down when pressed.
- If the operator releases the lift or lower buttons at any stage, the carriage will stop at its attained height.
- There is a red emergency stop on the top of the control panel. To stop all powered movement of the unit, press the button down. To reset the button, lift up.

**WARNING – DO NOT LEAVE A RAISED LOAD UNATTENDED**

## Clamping a Drum

### Requirements

- If loaded, the load must not exceed the unit's capacity.
- If loaded, load undamaged.
- Clamping pads in a vertical loading orientation.
- Batteries charged.

### Procedure

- Open the arms of the unit to full width by operating the two unclamp buttons. The unclamp function will only work when the two buttons are pressed together. This ensures that the drum can never be accidentally unclamped.
- Manoeuvre the unit so the pads straddle the drum. In the case of units with front gates fitted, the operator may have to lower the head over the drum. Ensure that the drum is in the centre of the pads, top to bottom as well as front to back, so they can encompass the drum when clamping.
- Operate the clamp function button to secure the drum between the pads. Refer to the clamping pressure section below for correct clamping pressures. The unit also features a limit switch that prevents a raised drum from being released once it has been lifted over a set height.
- The drum is now ready to be lifted, transported and rotated.
- There is a red emergency stop on the top of the control panel. To stop all powered movement of the unit, press the button down. To reset the button, lift up.
- **IMPORTANT** – Check the above steps have been completed correctly before you lift the drum off the floor. If you are in any doubt then contact the STS technical support line.
- To unclamp the load, press the two unclamp buttons. The unclamp function will only work when the two buttons are pressed together. This ensures that the load can never be accidentally unclamped.

**WARNING – DO NOT LEAVE A RAISED LOAD UNATTENDED**

## Clamping Pressures

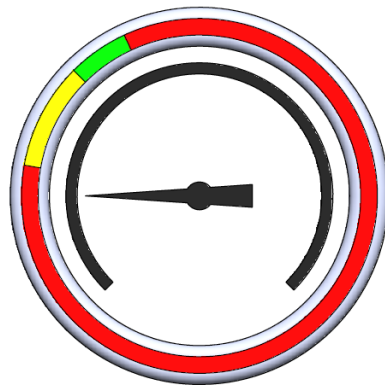

The unit holds and clamps a load in position using friction, so the unit is supplied with a pressure gauge to show the clamping force applied to the load being lifted.

Colour coded zones have been added to show the recommended pressure for clamping a load:

- RED – Pressure too low or too high. The load may slip out of the clamping pads or be crushed/damaged.
- GREEN – Recommended pressure for clamping a steel closed top drum and other solid drums.
- YELLOW – Recommended pressure for clamping softer and/or smaller loads. The operator must check that the clamping pressure is correct for the type of load being lifted. It is recommended that once the load has been clamped, the operator checks the load is secure at a low level prior to lifting. Applying manual force forwards and backwards to a clamped load should alert the operator of any issue.

**IMPORTANT** – Clamp pressure needle should reach and remain in the correct zone prior to lifting a load.

**WARNING – DO NOT LEAVE A RAISED LOAD UNATTENDED**

## Drum Rotating Head

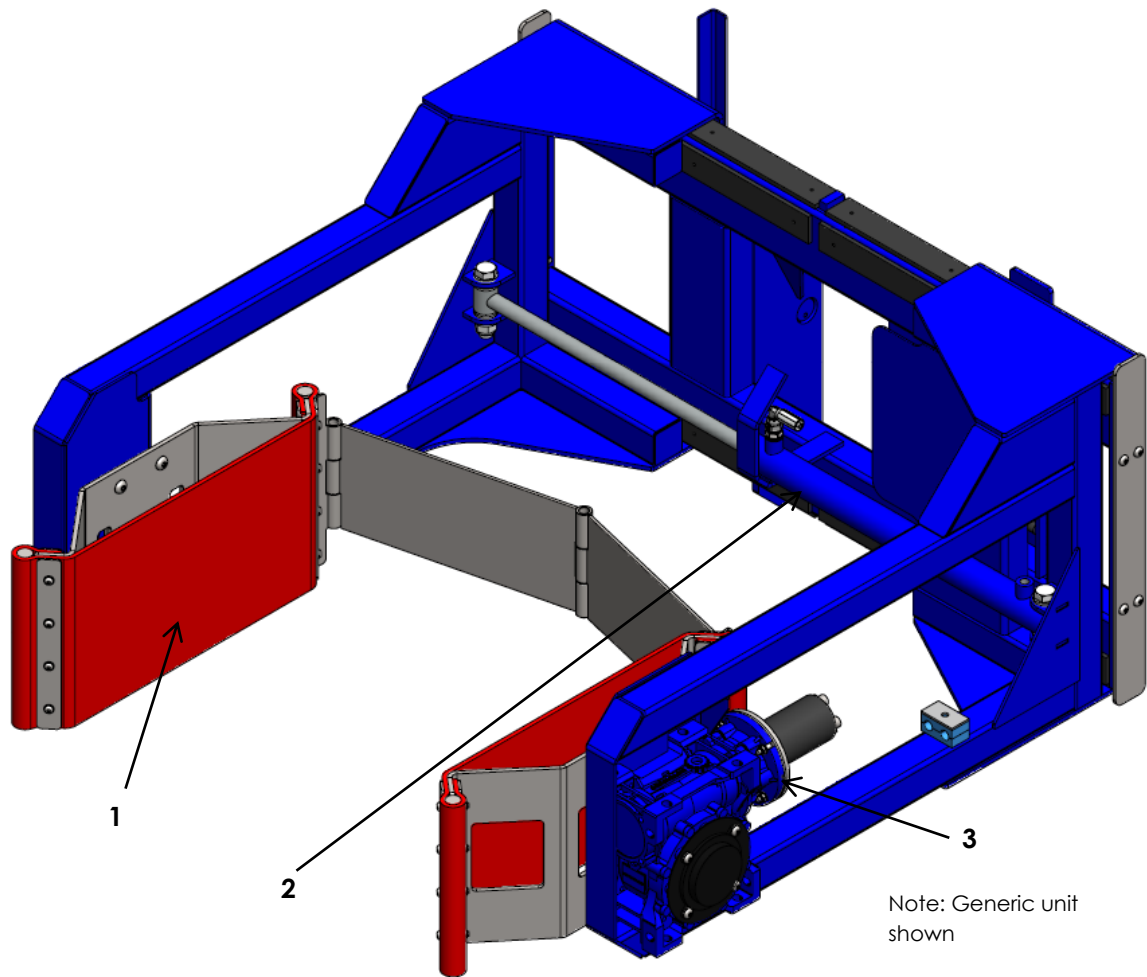

No.	Function
1	Flexible Clamp Pad
2	Clamping Ram
3	Gearbox Rotation

## Fitting the Drum Catch and Gates

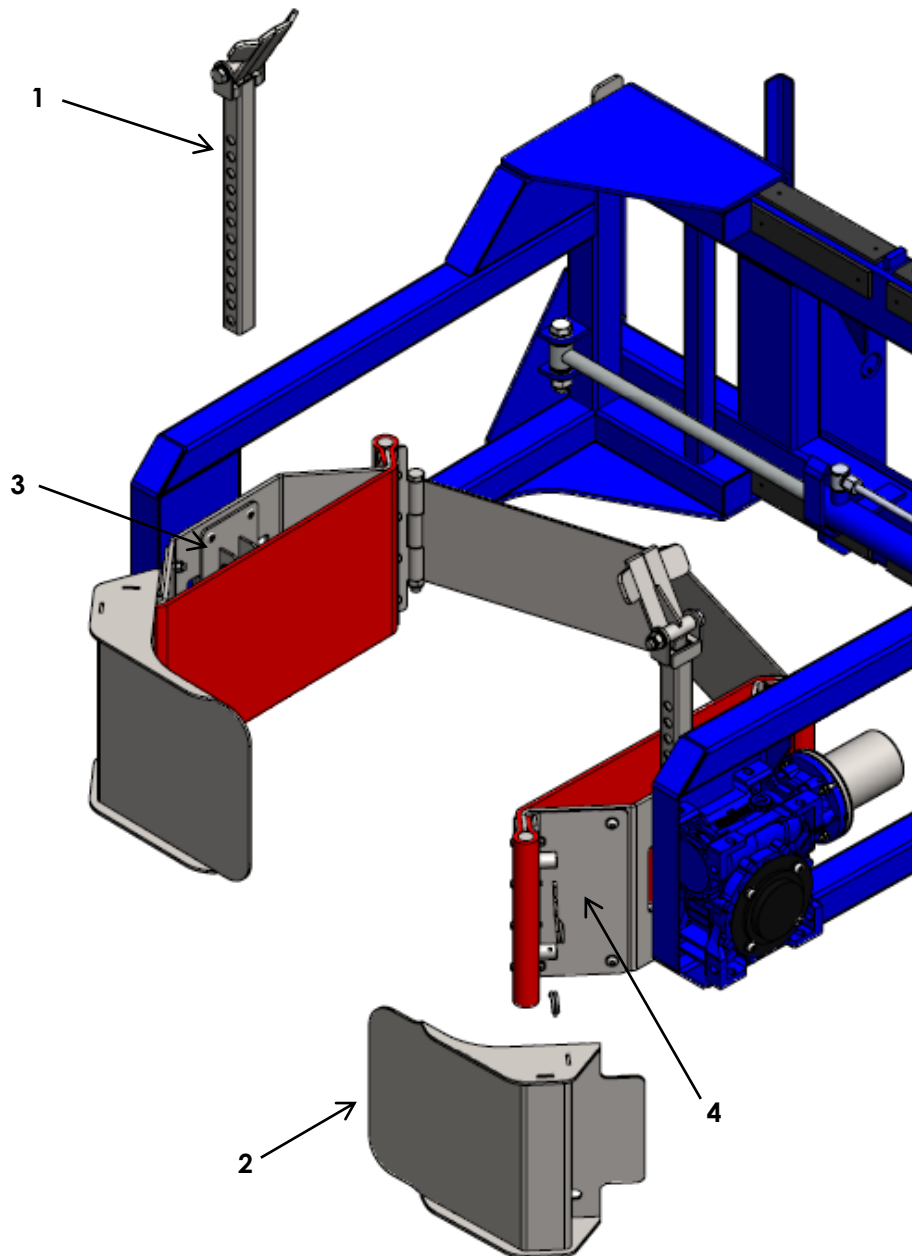

No.	Function
1	Rim Clamp
2	Gate
3	Rim Clamp Fins
4	Gate Bracket

### Procedure

- To fit the rim clamps, position the box section between the rim clamp fins and insert the pin into the highest hole, ensuring that the bottom of the box section is flush with the base of the rim clamp fins.
- To fit the gates, slide the pin into the gate bracket positioning holes and insert the supplied 'R' clips into the holes to lock into position.

## Tipping a Drum

### Requirements

- If loaded, the load must not exceed the unit's capacity.
- If loaded, load undamaged.
- If loaded, load clamped correctly.

### Procedure

- To tip the drum, press the tip/return buttons on the unit until the drum has reached the required orientation.

**WARNING – ENSURE THAT THE DRUM DOES NOT CLASH WITH THE FLOOR WHEN ROTATING. THIS MAY DAMAGE THE UNIT AND/OR LOAD.**

## Maximum Offset Load for Rotating a Load

The maximum allowable torque through the gearbox for rotating an offset load is 320Nm.

The loading scenario shown below is equivalent to the maximum allowable torque. The example shows a half-filled drum of extremely viscous contents, weighing 147kg, where the centre of mass of the load is offset by a distance of 221 mm.

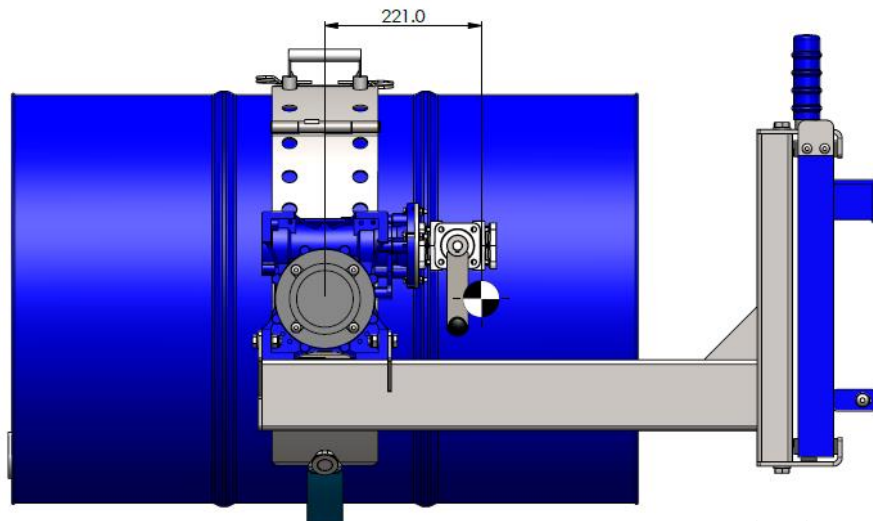

Note: Generic unit shown

**WARNING - ROTATING A DRUM WITH A HIGHER OFFSET LOAD IS TREATED AS MISUSE AND MAY DAMAGE THE UNIT.**

## Section IV – Unit Maintenance, Troubleshooting and Consumables

### Maintenance Checklist

The follow servicing checklist indicates the operations to be performed and the respective intervals to be observed. Maintenance intervals are defined as:

- W = Every 50 service hours, at least weekly
- A = Every 1000 service hours, at least annually
- = Standard maintenance interval

During the run-in period – after approx. 100 service hours – the owner must check the wheel nuts/bolts and re-tighten if necessary.

**NOTE:** Personal Protective Equipment (PPE) must be worn at all times, see ‘Section I – Correct Use and Application’ for more information.

**NOTE:** Maintenance must only be performed by a suitably competent individual as decided by the company the equipment is intended for use with. All electrical maintenance must only be performed by qualified personnel.

<b>Manual Braking (if applicable)</b>		<b>W</b>	<b>A</b>
1	Test brakes, adjust bolt if necessary	●	●

<b>Power Drive Braking (if applicable)</b>		<b>W</b>	<b>A</b>
1	Test automatic brake by accelerating the unit and releasing the throttle/button	●	●

<b>Hydraulic Operations</b>		<b>W</b>	<b>A</b>
1	Test hydraulic system	●	●
2	Check hydraulic oil and top up, if necessary, to the line or middle of the sight glass (see ‘Consumables’ for oil type and instructions)	●	●
3	Check that hydraulic ports, hose and pipe lines are secure, check for leaks and damage	●	●
4	Check cylinders and piston rods for damage and leaks, make sure they are secure		●
5	Test “hydraulic” controls and make sure the labels are present, legible and complete		●
6	Replace hydraulic oil (see ‘Consumables’ for oil type and instructions)		●
7	Check hydraulic oil for condensed water, replace if necessary (see ‘Consumables’ for oil type and instructions)		●

<b>Travel</b>		<b>W</b>	<b>A</b>
1	Check wheels for wear and damage, replace if necessary (see ‘Consumables’ for instructions)	●	●
2	Clean wheels if required	●	●

<b>Chassis and Superstructure</b>		<b>W</b>	<b>A</b>
1	Check doors and/or covers for damage	●	●
2	Check labels are legible and complete	●	●
3	Check guarding for damage and visibility, replace if necessary (see ‘Consumables’ for instructions)	●	●

4	Check chassis and fixing connections for damage		•
5	Check the load chains tension, adjust chains to the same tension if necessary		•
6	Check the load chains become slack when fully lowered, adjust if necessary	•	•
7	Check the load chains for wear and damage, clean if necessary		•
8	Apply chain lubricant spray, PTFE or food grade chain lubrication spray		•
9	Visually inspect the mast bearings and check the contact surface wear level, grease if necessary		•
10	Check lateral clearance of mast connections and carriage		•
11	Check carriage and head (load handler) for wear and damage		•
12	Check channels and bearings for cracks and/or damage		•
13	If applicable, check clamping pads for wear and/or damage, replace if necessary (see 'Consumables' for instructions)	•	•
14	If applicable, check the blue ratchet strap for wear and/or damage, replace if necessary (see 'Consumables' for instructions)	•	•

<b>Ex Checks (-Ex models only)</b>		<b>W</b>	<b>A</b>
1	Check wheels for dirt and grime, clean if required	•	•
2	Clean unit, ensure dirt and dust free	•	•
3	Ensure earthing chains are fitted and in contact with the ground	•	•
4	Check and clean, if required, the clamping pads on the head of the unit	•	•
5	Check unit for any damaged painted surfaces, touch up, if necessary, with an approved touch up paint	•	•
6	Check, if originally fitted, stainless steel guarding plates are in place and undamaged	•	•

<b>Pneumatic Operations (if applicable)</b>		<b>W</b>	<b>A</b>
1	Check and replace, if required, pneumatic filter elements		•
2	Test emergency stop	•	•
3	If applicable, test the horn	•	•
4	Disconnect airline to allow air filter regulator to drain	•	•

<b>Electrical System (if applicable)</b>		<b>W</b>	<b>A</b>
1	Test warning and safety devices in accordance with operating instructions	•	•
2	Test emergency stop	•	•
3	If applicable, test the horn	•	•
4	Check electric wiring for damage (insulation damage, connections). Make sure wire connections are secure		•
5	Check contactors and/or relays		•
6	Ensure that there is no potential difference between the unit chassis and the battery negative and also between the unit chassis and the charger earth		•
7	Check battery and battery components		•
8	Check battery cable connections are secure, grease terminals if necessary		•
9	Check battery connector for damage, test it and make sure it is secure		•
10	Charger, check mains connector and mains cable		•
11	Charger, check the wires and electrical connections are secure and not damaged		•
12	Inspect electrical contact to ensure they are clean, tight and free from corrosion or heats damage from arcing.		•
13	If applicable, check power drive disconnects when charging		•

**OPERATORS SHOULD REPORT ANY DEFECTS ON THE UNIT TO THE APPROPRIATE PERSON. IF IN ANY DOUBT, OR SHOULD REPLACEMENT PARTS BE NEEDED, PLEASE CONTACT THE STS TECHNICAL SUPPORT LINE.**

## Troubleshooting

When trying to locate a fault, proceed in the order shown in the table.

**NOTE:** Troubleshooting must only be performed by a suitably competent individual as decided by the company the equipment is intended for use with.

If, after carrying out the following remedial actions, the unit cannot be restored to operation, contact the manufacturer's technical helpline. In order for customer services to react quickly and specifically to the fault, the following information is essential:

- Unit serial number
- Description of error
- Unit product name
- Current location / Company

### Unit does not start (Electrically powered)

Possible Cause	Action
Emergency stop pressed	Reset the emergency stop button
Key switch set to 'Off'	Set key switch to 'On'
Battery charge too low	Check battery charge and charge battery if necessary
Faulty fuse	Check fuses

### Load cannot be lifted (Electrically or pneumatically powered)

Possible Cause	Action
The load exceeds the SWL	Reduce mass of load
Load incorrectly secured	See instructions for clamping and lifting
Hydraulic oil level too low	Check hydraulic oil level
Emergency stop engaged	Reset emergency stop button(s)
Air pressure too low, if applicable	Check air supply, if applicable
Air flow too low, if applicable	Check air supply, if applicable

### Load cannot be lifted (Manually powered)

Possible Cause	Action
The load exceeds the SWL	Reduce mass of load
Load incorrectly secured	See instructions for clamping and lifting
Hydraulic oil level too low	Check hydraulic oil level

### Load cannot be lowered (Electrically or pneumatically powered)

Possible Cause	Action
The load exceeds the SWL	Reduce mass of load
Hydraulic oil level too low	Check hydraulic oil level
Emergency stop engaged	Reset emergency stop button

**Load cannot be rotated (Electrically or pneumatically powered)**

Possible Cause	Action
The load exceeds the SWL	Reduce mass of load
Off-centre load too high	Reduce off-centre load
Hydraulic oil level too low	Check hydraulic oil level
Emergency stop engaged	Reset emergency stop button
Air pressure too low, if applicable	Check air supply, if applicable
Air flow too low, if applicable	Check air supply, if applicable

**Load cannot be rotated (Manually powered)**

Possible Cause	Action
The load exceeds the SWL	Reduce mass of load
Off-centre load too high	Reduce off-centre load

**Load cannot be clamped (Electrically or pneumatically powered)**

Possible Cause	Action
Load outside useable size range	Refer to specification stated in 'Unit Description'

**Unit cannot be moved (Pedestrian powered)**

Possible Cause	Action
Rear parking brakes are engaged	Release the rear parking brakes

**Unit cannot be moved (Electrically powered power drive units)**

Possible Cause	Action
Emergency stop pressed	Reset the emergency stop button
Key switch set to 'Off'	Set key switch to 'On'
Battery charge too low	Check battery charge and charge battery if necessary
Faulty fuse	Check fuses
Tiller in the vertical or horizontal position	Adjust tiller angle to allow unit movement

**Unit cannot be moved (Pneumatically powered power drive units)**

Possible Cause	Action
Airline not connected	Reconnect airline
Emergency stop pressed	Reset the emergency stop button
Tiller in the vertical or horizontal position	Adjust tiller angle to allow unit movement

## Consumables

All unit consumables are available from STS. The unit must be fitted with original STS consumables unless otherwise stated. Any deviation from original consumables may result in injury to personnel or damage to the unit and will invalidate the warranty.

## Oil Replacement

STS stackers are factory-equipped with Shell Tellus 32 oil for the hydraulic system. It is recommended to use as stated or an equivalent when replacing hydraulic oil.

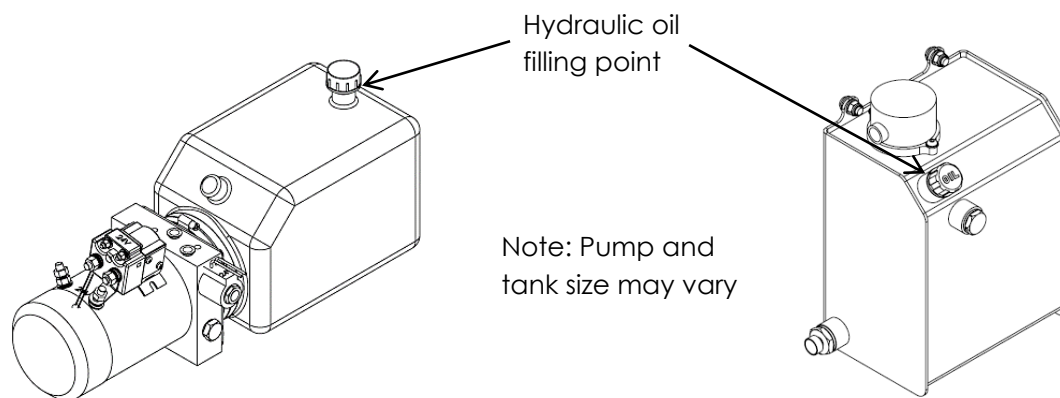

When replacing oil, fill oil to the line or to the middle of the sight glass. Operate all unit functions to their full extents. Return unit head to its lowest position and recheck the oil level, top up if required.

## Clamping Pad Replacement

The clamping pads should be replaced if they show signs of wear or damage. They should also be replaced if the rubber bands become slack within their retaining frame, with regular use this should be at most once per year. These are available from STS.

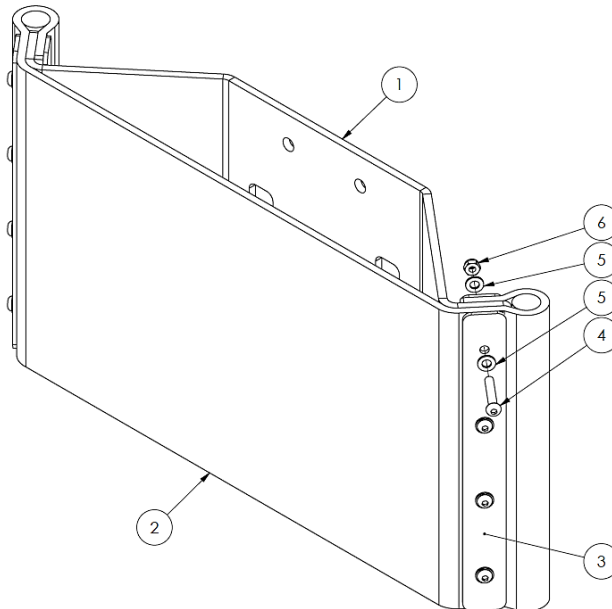

Item	Description	Qty.
1	Flexible Clamp Pad Frame, F/ RRH01, Weldment, Stainless Steel	1
2	Rubber Clamping Pad, F/ RRH01, 685mm X 252mm, Anti-Static	1
3	RRH01 Belt Clamp Plate, 250mm X 30mm X 3mm THK, AISI 304	4
4	Pozi Pan Head Screw, M6 X 35, A2	8
5	Washer, M6, A2	16
6	Nyloc Nut, M 6, A2	8

Each clamping pad is fitted using four M10 x 20mm bolts and four M10 washers into tapped holes within the rotation mating plate. To replace the pads, unbolt the pad using a 17mm spanner. Apply thread lock to each bolt prior to re-fitting.

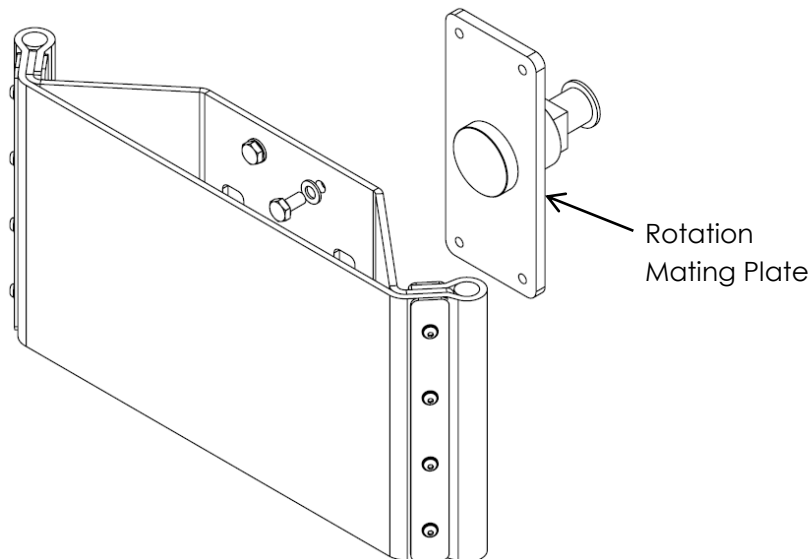

## Polycarbonate Guarding Replacement

The polycarbonate guarding should be replaced if damaged, cracked or visibility is reduced. These are available from STS.

To replace the polycarbonate guard, isolate the unit in a safe area, then proceed as follows:

- Remove the four M5 bolts, if applicable, located in each corner and remove the old guard.
- On the new polycarbonate guard, peel back the protective film along all long edges.
- Slide the new polycarbonate guard into one side of the guarding frame. The recommended method to bend the polycarbonate guard into position is to have a second person assist. The first person must push the guarding edge into the guarding frame whilst the second person pushes the polycarbonate guard from the opposite side. The second person should apply pressure centrally to help form the required curve. Once a small section of polycarbonate guard edge is positioned into the guarding frame, press in the remaining edge whilst taking care to ensure fingers do not become trapped.
- Once the polycarbonate guard is in position, if applicable, use the existing four holes in the guarding frame as a jig to drill a 4.2mm drill bit through the polycarbonate guard and then tap to M5.
- Once tapped, use the four M5 bolts to secure the polycarbonate guard in place.

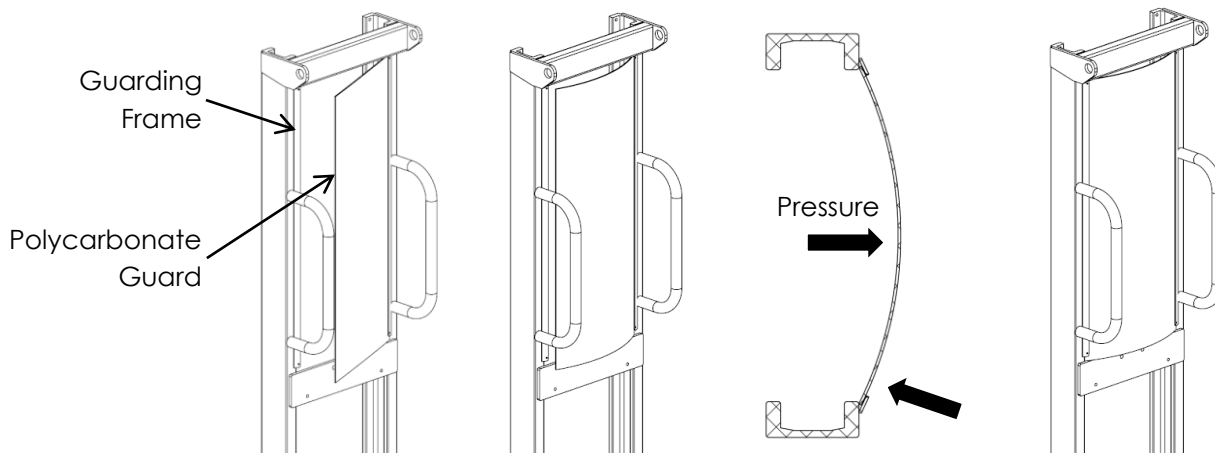

Note: Generic unit shown

## Battery Replacement

Batteries should be replaced if damaged, leaking or no longer holding a charge. These are available from STS.

Battery specifications can be located within the 'Charging Operation' section.

To replace the battery/batteries isolate the unit in a safe area ensuring that the unit is disconnected from a mains power supply, the power key is in the 'off' position and the emergency stop is pressed. Remove the control box cover and disconnect the battery clamp or battery strap.

For 12-volt power units, isolate power from the battery by disconnecting the negative cable (black) first then the positive cable (red).

For 24-volt power units, isolate power from the batteries by disconnecting the negative cable (black) first then the positive cable (red). Then disconnect the joining cable.

To replace the batteries, follow the above instructions in reverse.

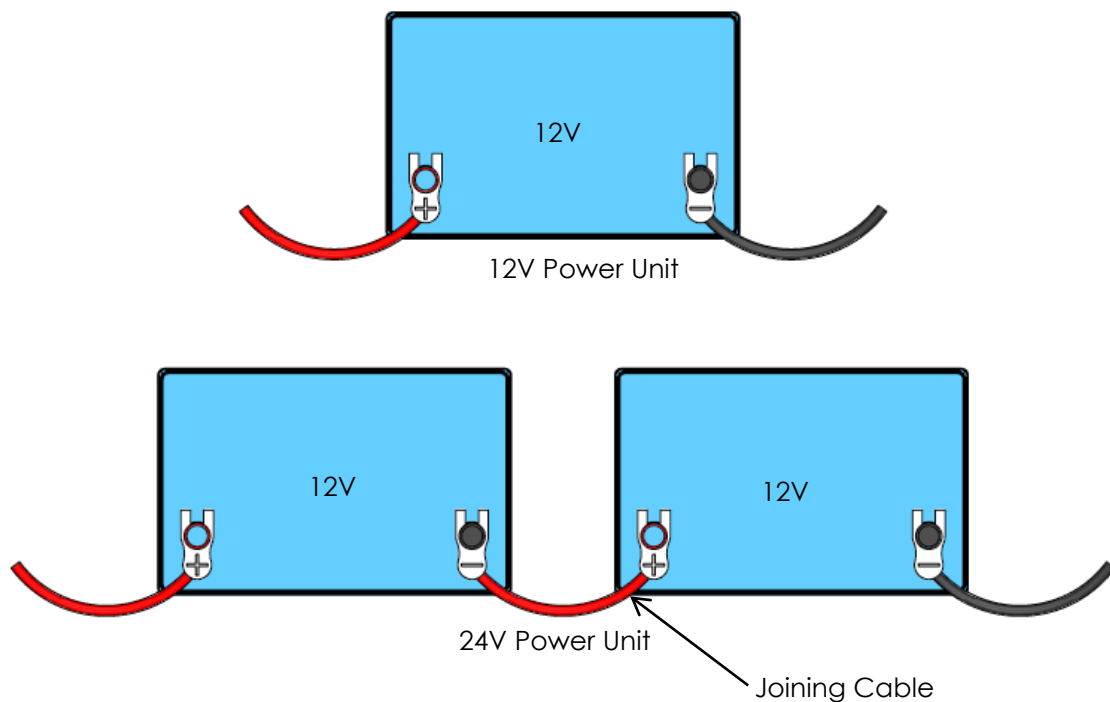

### **WARNING - ISOLATE UNIT BEFORE ACCESSING THE BATTERY/BATTERIES**

When changing batteries, all batteries should be changed for new ones. Batteries must be from the same manufacturer and of the same specification.

## Safety Regulations Governing the Handling of Lead-Acid Batteries

### Maintenance personnel

Batteries may only be charged, serviced or replaced by trained personnel. This operator manual and the manufacturer's instructions concerning batteries and charging stations must be observed when carrying out the work.

### Fire protection

Do not smoke and avoid naked flames when handling batteries. Wherever a unit is parked for charging there shall be no inflammable material or lubricants capable of creating sparks within 2m around the unit. The room must be well ventilated. Fire protection equipment must be on hand.

### Battery maintenance

The battery cell covers must be kept dry and clean. The terminals and cable shoes must be clean, secure and have a light coating of dielectric grease.

### Battery disposal

Batteries may only be disposed of in accordance with national environmental protection regulations or disposal laws. The manufacturer's disposal instructions must be followed.

**WARNING - BATTERIES CAN BE HAZARDOUS. BATTERIES CONTAIN AN ACID SOLUTION WHICH IS POISONOUS AND CORROSIVE. ABOVE ALL AVOID ANY CONTACT WITH BATTERY ACID.**

- Dispose of used battery acid in accordance with regulations.
- Always wear protective clothing and safety glasses when working with batteries.
- Do not let battery acid come into contact with skin, clothing or eyes. If necessary, rinse with plenty of clean water.
- Call a doctor immediately in the event of physical damage (e.g. skin or eye contact with battery acid).
- Neutralise any spilled battery acid immediately with plenty of water.
- Only batteries with a sealed battery container may be used.
- Follow national guidelines and legislation.

### Using unsuitable batteries can cause accidents

The weight and dimensions of the battery have a considerable effect on the operation safety and capacity of the unit. Changing the battery features requires the manufacturer's approval, as compensating weights are required if smaller batteries are fitted. When replacing/installing the battery make sure the battery is securely located in the battery compartment of the unit.

Park the unit securely before carrying out any work on the batteries.

## Battery Charging Safety

### **WARNING - THE GASES PRODUCED DURING CHARGING CAN CAUSE EXPLOSIONS**

The battery produces a mixture of nitrogen and hydrogen (electrolytic gas) during charging. Gassing is a chemical process. This gas mixture is highly explosive and must not be ignited.

- STS units are supplied with either an external or an on-board charger. The charger supplied is designed only to charge the battery/batteries within that unit. No other charger should be used to charge the unit battery/batteries as this may cause damage.
- Always switch the charging station and the unit off before connecting/disconnecting the charging cable.
- Before charging, check all cables and plug connections for visible signs of damage.
- The room in which the unit is being charged must be well ventilated.
- Do not smoke and avoid naked flames when handling batteries.
- When parking the unit, ensure the area contains no inflammable material or lubricants capable of creating an ignition source within an area of 2 metres around the unit.
- Fire protection equipment must be on hand.
- Do not lay any metallic objects on the battery/batteries.
- It is essential to follow the safety regulations of the battery, the battery charger and charger station manufacturers.

### **WARNING - BATTERY POWERED UNITS ARE NOT PERMITTED FOR USE IN AN ATEX RATED ENVIRONMENT.**

## Wheel Replacement

Wheels should be replaced if damaged, cracked or delaminated. These are available from STS.

Isolate the unit in a safe area ensuring that the unit is disconnected from any power supply and that the emergency stop is pressed. The unit must be on a flat and level floor.

For safety instructions refer to 'Lifting the Unit' in 'Section I – Correct Use and Application'

To replace the front wheels, remove wheel guard (if applicable) and jack up the leg by 10mm so that the wheel is clear of the floor. Unbolt the wheel using two 19mm spanners. Replace the wheel ensuring that the wheel bushes are re-fitted into the wheel prior to re-bolting. Repeat this process for the other leg. When low level legs are fitted with pallet roller wheels, the 20mm diameter wheel pin will need to be removed. To do this, remove the button head bolt and hammer out the pin.

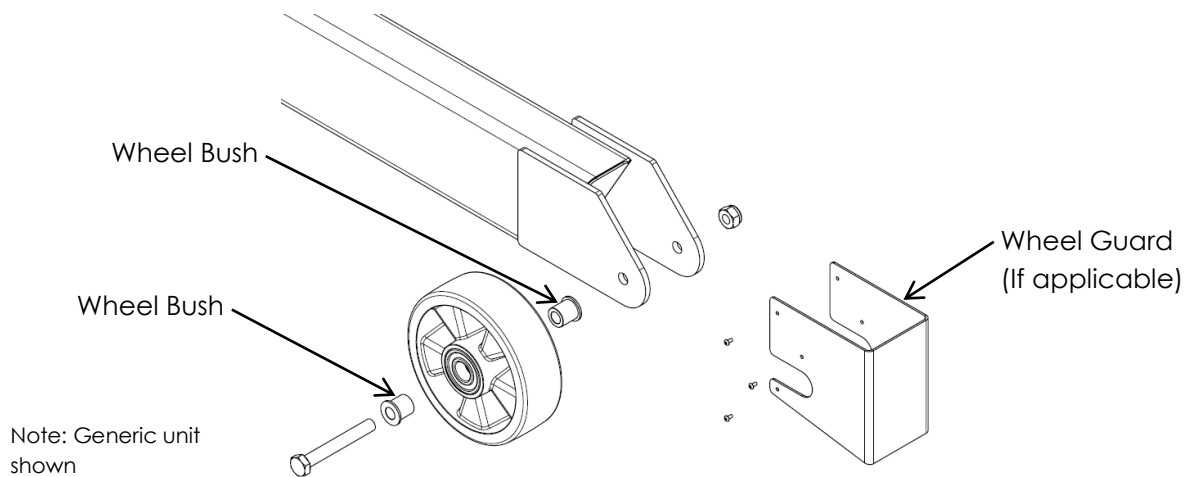

To replace the rear wheels, ensure that the head of the unit is in its lowest position. Place a wooden block or equivalent under the rear wheel legs, behind the steering mechanism, and jack up both wheels centrally under the unit by 150mm. Unbolt each wheel using two 19mm spanners. Replace the wheels ensuring that the wheel bushes are re-fitted into the wheels prior to re-bolting.

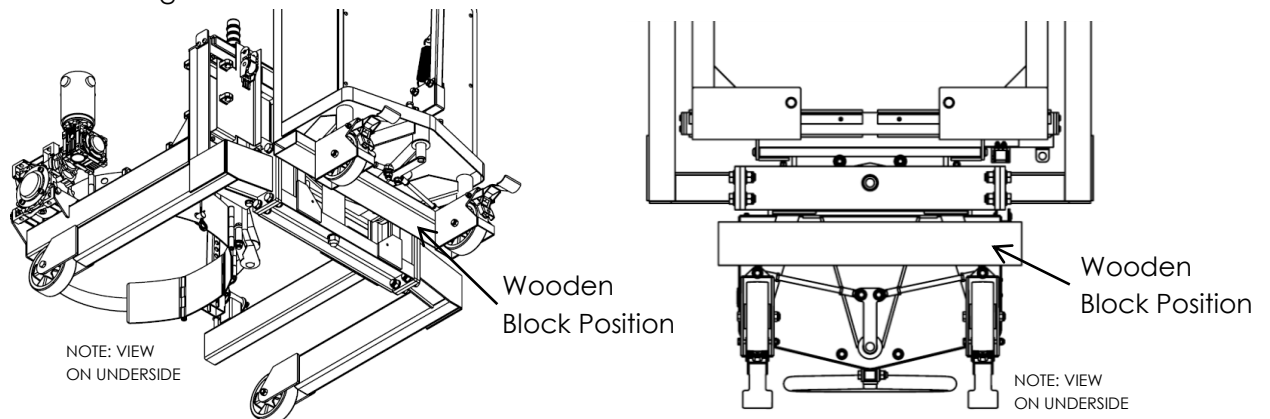

**WARNING – DO NOT JACK THE UNIT MORE THAN NECESSARY AS UNIT MAY BECOME UNSTABLE**

## Section V - Technical Specification

### General Arrangement

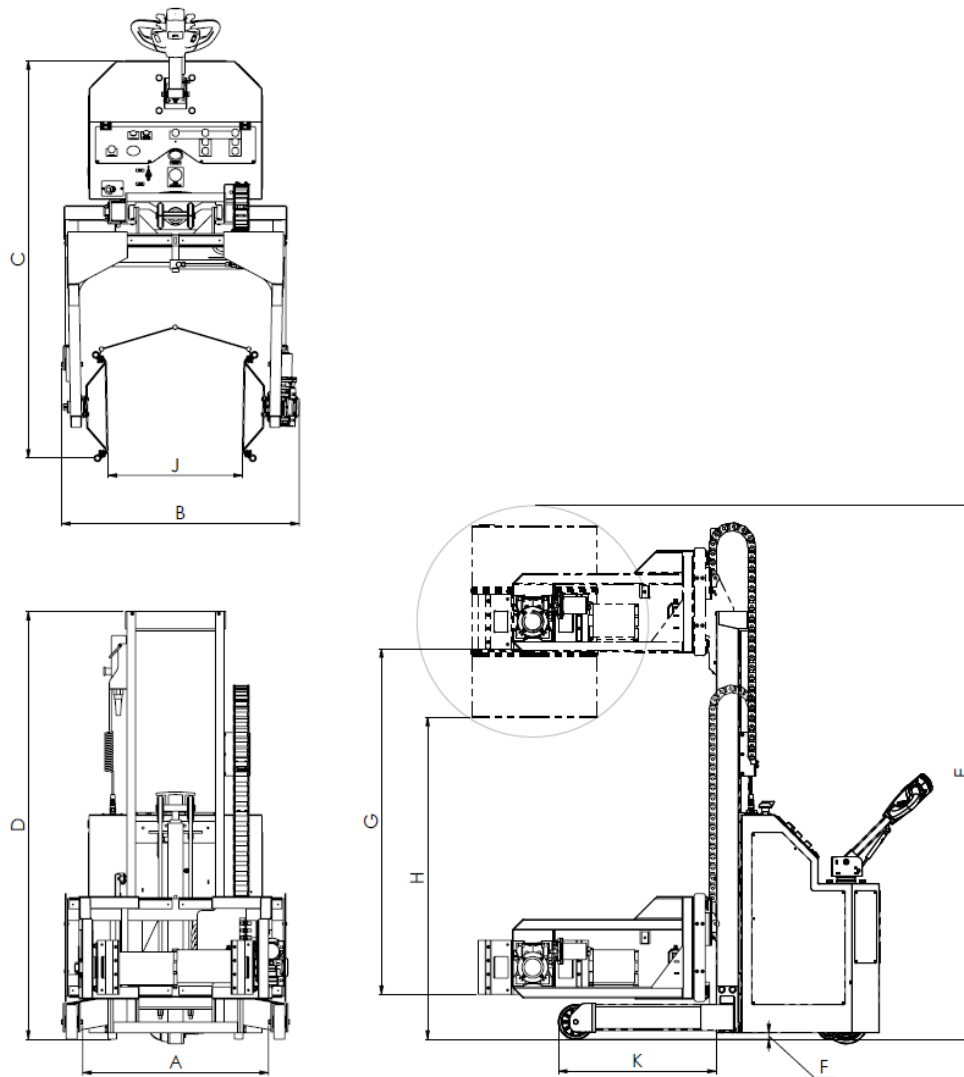

NOTE: ALL DIMENSIONS +/- 5MM.

Designation	Description	Dimension (mm)
A	Straddle	850
B	Maximum Width	1150
C	Maximum Length	1880
D	Mast Height	1980
E	Maximum Height	2490
F	Ground Clearance	30
G	Lift Stroke	1600
H	Maximum Distance Under Drum	1450
J	Drum Diameter Clamping Range	250-620
K	Leg Length	730

**SWL** 300kg  
**Net Mass** 526kg

**Max Noise Level** 79dBa  
**System Voltage** 24V

**Nominal Power** 2200W

## Section VI - Decommissioning the Unit

If the unit is to be out of service for more than a month, e.g. for commercial reasons, it must be stored in a frost-free and dry room. All necessary measures must be taken before, during and after decommissioning as described hereafter. Decommissioning and recommissioning must only be performed by a suitably competent individual as decided by the company the equipment is intended for use with.

**NOTE:** Personal Protective Equipment (PPE) must be worn at all times, see 'Section I – Correct Use and Application' for more information.

### Prior to Decommissioning

- Thoroughly clean the unit.
- Test the brakes (if applicable).
- Check the hydraulic oil and replenish if necessary (if applicable).
- Fully charge then disconnect the battery. Charge the battery every 2 months to protect from long term "non-use" damage (if applicable).
- Apply a thin layer of oil or grease to any non-painted mechanical components.

### Final Decommissioning and Disposal

Final decommissioning or disposal of the unit must be performed in accordance with the regulations of the country of use. In particular, regulations governing the disposal of batteries, fuels and electronic and electrical systems must be observed. The unit must only be disassembled by trained personnel.

### Recommissioning

- Reconnect the battery, first ensuring that the battery undamaged (if applicable).
- Follow the annual servicing check list located in 'Maintenance Checklist'.
- Follow the pre-start checklist located in 'Pre-start Inspections'.

### Safety Tests to be Performed at Intervals and After Unusual Incidents.

Perform a safety check in accordance with national regulations. The unit must be inspected at least annually or after any unusual event by a qualified inspector. The inspector shall assess the condition of the unit from purely a safety viewpoint, without regard to operational or economic circumstances.

For further help contact STS:

**Technical Support Line: +44 (0) 1736 851050**

In the interest of all concerned it is essential that equipment of our manufacture is used only for the purposes for which it has been designed and it must be used in accordance with the instructions which are supplied.