

Operating Instructions

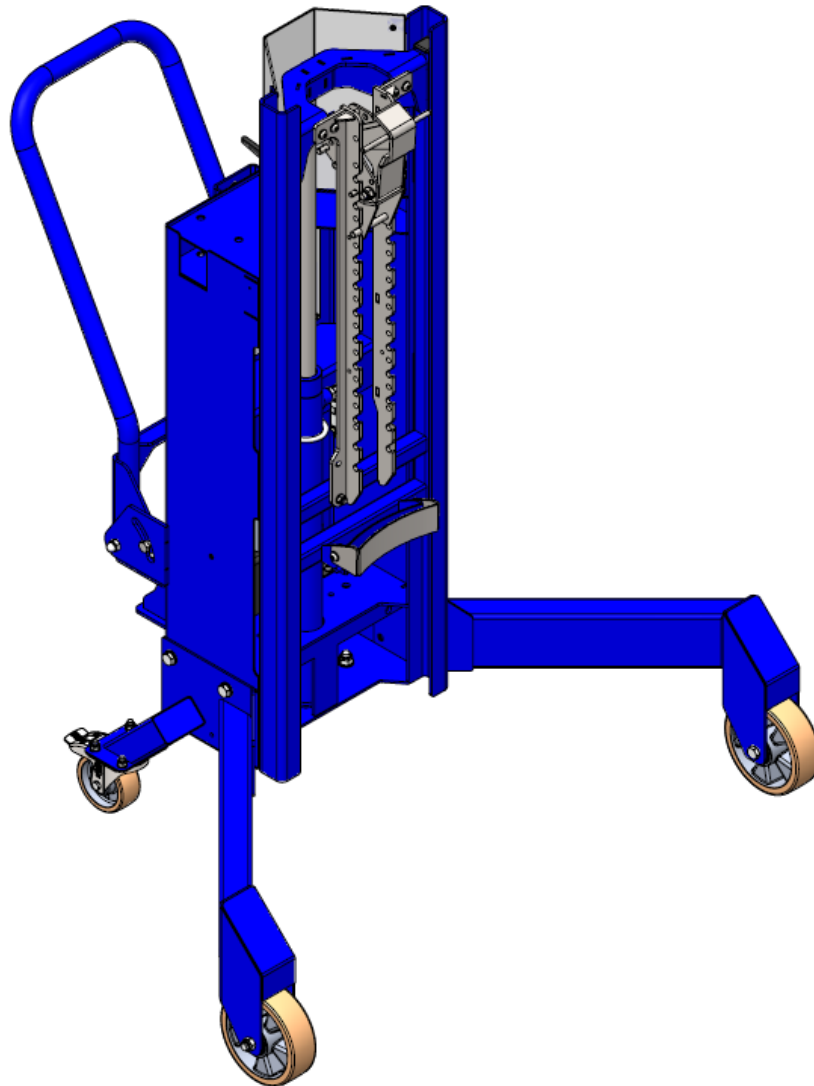

DTP05(-Ex)

Corner Drum Lifter

Bespoke Handling Equipment Ltd.
Leedstown
Hayle
Cornwall
United Kingdom
TR27 6DS

E-mail: sales@sts-trolleys.co.uk
Tel: +44 (0)1736 851050
Website: www.sts-trolleys.co.uk

Section I – Correct Use and Application	2
General	2
Foreseeable Misuse of the Unit	2
Approved Application Conditions	2
Proprietor Responsibilities	3
Adding Attachments and/or Accessories	3
Safety Regulations for the Operation of the Unit	3
Consumables and Parts	5
ATEX Certified Units (if applicable)	5
Lifting the Unit	6
Unit Overview	7
Section II – Unit Description	8
Section III – Unit Operation	9
Initial Setup and Connecting to Drums.....	9
Removing Drums from a Pallet	10
Universal Drum Catch Variations.....	11
Top Hook Forward Reach Configuration Table.....	11
Section IV – Unit Maintenance, Troubleshooting and Consumables	12
Maintenance Checklist	12
Troubleshooting	13
Consumables	14
Oil Replacement.....	14
Touch Up Paint.....	14
Polycarbonate Guarding Replacement	14
Wheel Replacement	15
Section V - Technical Specification	16
General Arrangement	16
Section VI - Decommissioning the Unit	17
Prior to Decommissioning.....	17
Final Decommissioning and Disposal	17
Recommissioning.....	17
Safety Tests to be Performed at Intervals and After Unusual Incidents.	17

Section I – Correct Use and Application

General

The unit described in the present operating instructions must be used, operated and serviced in accordance with the present instructions. Any other type of use is beyond the scope of application and can result in damage or injury to personnel, the unit or property. The unit described in the present operating instructions complies with BS EN ISO 17050-1:2010 and the EC Machinery Directive 2006/42/EC.

Foreseeable Misuse of the Unit

Personnel must take care when operating the unit. The following actions must be adhered to:

- The maximum safe working load (SWL) must not be exceeded.
- Do not travel with a raised load 500mm above the ground unless necessary.
- When manoeuvring the unit, do not exceed a speed of 1m/s (3.6km/h).
- When manoeuvring a raised load above 500mm, do not exceed a speed of 0.1m/s (0.36km/h).
- If applicable, do not over lower the head of the unit onto a platform, such as a mezzanine floor.
- Do not carry or lift other personnel.
- Do not stand or ride on the unit.
- Loads must be undamaged.
- Do not negotiate inclines unless otherwise stated.
- Do not stand underneath a raised load or within the confines of the unit during operation.
- The load must be lifted and/or mixed by the attachment provided.
- Do not alter the unit specification from original supply.
- Do not disable, remove or adjust safety mechanisms or switches.
- Observe all instruction decals applied to the unit.
- Do not leave the unit in direct sunlight.
- The manufacturer shall not be held liable in case of faults or accidents due to negligence, incapacity, installation by unqualified personnel or improper use.

Approved Application Conditions

- Operation in dry industrial and commercial environments.
- Permissible temperature range -20°C to 40°C.
- Lighting of at least 300 Lux.
- Altitudes not exceeding 2000m.
- Operation only on secure, level surfaces with sufficient capacity.
- Operation only on routes that are visible and approved by the proprietor.
- Operation in accordance with guidance stated within the operating instructions.
- The unit must be maintained in accordance with the maintenance schedule stated within the operating instructions.
- Appropriate personal protective equipment, PPE, must be worn at all times.

Proprietor Responsibilities

For the purposes of the present operating instructions the “proprietor” is defined as any natural or legal person who either uses the unit themselves, or on whose behalf it is used. In special cases (e.g. leasing or renting) the proprietor is considered the person who, in accordance with existing contractual agreements between the owner and user of the unit, is charged with operational duties. The proprietor must ensure that the unit is used only for the purpose for which it is intended and that there is no danger to life or limb of the user and third parties. Furthermore, accident prevention regulations, safety regulations and operating, maintenance and repair guidelines must be followed. The proprietor must ensure that all users have read and understood these operating instructions. The proprietor must perform an onsite risk assessment before the unit is put in to service.

IMPORTANT

Failure to comply with the operating instructions shall invalidate the warranty. The same applies if improper work is carried out on the unit by the proprietor or third parties without the permission of the manufacturer.

Adding Attachments and/or Accessories

The mounting or installation of additional equipment which affects or enhances the performance of the unit requires written permission of the manufacturer. Local authority approval may also need to be obtained. Local authority approval does not however constitute the manufacturer’s approval. An onsite risk assessment must then be carried out.

WARNING - ANY UNAUTHORISED MODIFICATIONS OR ADDITIONS TO THE UNIT SHALL INVALIDATE THE WARRANTY AND STS SHALL NOT BE LIABLE.

Safety Regulations for the Operation of the Unit

Operator authorisation

The unit may only be used by suitably trained personnel, who have demonstrated to the proprietor, or their representative that they can operate the unit safely and in accordance with the operating instructions.

Operators rights, obligations and responsibilities

The operator must be informed of their duties and responsibilities and be instructed in the operation of the unit and shall be familiar with the operating instructions. Operators must be provided the appropriate PPE as mentioned in the ‘Approved Application Conditions’ section of this manual.

Unauthorised use of unit

The operator is responsible for the unit during the time it is in use. The operator must prevent unauthorised persons from operating the unit.

Damage and faults

The proprietor must be immediately informed of any damage or faults to the unit or attachment. Units which are unsafe for operation must be quarantined until faults have been rectified and the unit deemed safe for operation.

Servicing and repairs

All unit parts and consumables are available from STS. The unit must be fitted with original STS parts and consumables unless otherwise stated. Any deviation from non-original parts and consumables may result in injury to personnel or damage to the unit and will invalidate the warranty. The operator must never disable, remove or adjust safety mechanisms or switches. The unit should only be serviced and repaired by a competent individual as selected by the company the equipment is intended for use with.

Safety devices and warning decals

Safety devices, warning decals and warning instructions in the operating instructions and on the unit must be strictly observed.

Travel routes and operational areas

Only use lanes and routes specifically designated for unit traffic. Unauthorised third parties must stay away from operational areas. The unit must only be operated in operational areas with sufficient lighting to avoid damage or injury to personnel, the unit or property. Additional equipment is necessary to operate the unit in areas of insufficient lighting.

Hazardous area of the unit

The hazardous area is defined as the area in which a person is at risk due to the unit itself or movement of the unit and/or load. This also includes areas which can be reached by falling loads. The operator must:

- Instruct unauthorised personnel to leave the hazardous area.
- Give a warning signal with plenty of time for personnel to leave.
- Stop all operations if unauthorised personnel are within or enter the hazardous area.

Travel conduct

The operator must adapt the travel speed to local conditions. The unit must be driven at slow speed when negotiating bends or narrow passageways, when passing through swing doors and at blind spots. Abrupt stopping (except in emergencies), rapid U turns and overtaking at dangerous or blind spots are not permitted. When not in use, the equipment should be parked in a safe location with the brakes engaged.

Travel visibility

The operator must look in the direction of travel and must always have a clear view of the route ahead. When transporting loads that affect visibility, a second person must safely assist the operator to observe the travel route.

Type of loads

The operator must make sure that the load is in a satisfactory condition. Loads must always be positioned safely and carefully. Use suitable precautions to prevent parts of the load and/or their contents from falling or spilling.

Cleaning

Cleaning of the unit depends on the environment that the unit is used in. It is recommended that the unit be cleaned daily if the unit comes into contact with aggressive substances such as chemicals, fertilizers, salt, etc. It is recommended to use detergent and a damp cloth to clean the body of the unit. Do not use flammable liquids to clean the unit. Do not clean the unit with pressurised water. If the unit is rated for ATEX environments, the unit must be kept clean and dust free.

Personal protective equipment (PPE)

PPE must be worn at all times. A minimum of safety shoes must be worn while operating the unit. Safety shoes, safety glasses, protective gloves, hearing protection and protective overalls are to be worn when carrying out servicing, repairs and maintenance. When operating overhead loads, a hard hat must be worn. End user health and safety procedures and best practices should be followed in addition to the above recommendations.

Consumables and Parts

Environmental hazards

Parts and oils must be disposed of in accordance with the relevant environmental protection regulations.

Hydraulic hoses (if applicable)

Brittle hydraulic hose lines cause accidents. Hairline cracks in the hydraulic lines can cause injury and infection. The hydraulic hoses should only be serviced or replaced by a competent individual as selected by the company the equipment is intended for use with. It is the responsibility of the proprietor to maintain the hydraulic hoses.

Lift chains (if applicable)

Incorrectly cleaned chains can cause accidents. Lift chains are safety-critical parts. They must not contain any serious contamination. Lift chains and pivot pins must always be clean. Never clean chains with high pressure steam jet cleaners, cold or chemical cleaning agents. It is recommended to clean the chains and pivot pins in an unloaded state with a citrus cleaner to remove dirt and grime followed by the application of a PTFE based industrial grade chain lubrication spray or food grade lubrication spray.

NOTE: For more consumable information refer to 'Section IV – Unit Maintenance, Troubleshooting and Consumables'.

ATEX Certified Units (if applicable)

Operational hazards

Processing of liquids or suspensions (mixing or stirring, filling or draining) can give rise to ignition risks due to static electricity including the risk of propagating brush discharges. The processing of liquids or suspensions is the responsibility of the end user.

Environmental hazards

Care should be taken by the end user to ensure collisions do not occur between the unit and its surrounding environments which may create a potential ignition source.

Earthing chains

Ensure earthing chains are securely fitted and are in contact with the ground at all times, wheels should be kept clean and free from debris.

Electrically powered units

Care should be taken by the end user to ensure any electrical cables to and/or from the unit are kept away from travel areas where they may become entangled, damaged or be a trip hazard. Electrical cables must be kept dry, clean and be routinely checked as stated in the maintenance procedures. Any cracked or damaged electrical cables must be reported immediately and the unit be put out of service until resolved.

Lifting the Unit

Lifting the unit safely

In order to raise the unit safely, including off a pallet, proceed as follows:

- The unit must be on a level surface to prevent it from moving accidentally.
- The lifting gear must only be secured to the points designated for this purpose.
- Always use lifting gear with sufficient capacity.
- The unit should only be handled by qualified personnel who are trained in using lifting slings and tools.
- Do not walk into or stand under a raised unit.
- If necessary, secure the unit with guide ropes to aid when lifting the unit.

Jacking the unit safely

In order to jack up the unit safely, proceed as follows:

- The unit must be on a level surface to prevent it from moving accidentally.
- Always use a jack with sufficient capacity.
- The unit should only be handled by qualified personnel who are trained in using lifting slings and tools.
- When jacking up the unit, take appropriate measures to prevent it from moving, slipping or tipping over (e.g. wedges, wooden blocks, stops)

WARNING - IMPROPER LIFTING CAN RESULT IN SERIOUS ACCIDENTS

Securing the unit for transport

In order to transport the unit safely, proceed as follows:

- The unit must be securely fastened when transported on a lorry/trailer.
- The lorry/trailer must have fastening rings.
- Use wedges to prevent the unit from moving.
- Use only tension belts or tie-down straps with sufficient strength.

WARNING - IMPROPER FASTENING OF THE UNIT DURING TRANSPORT CAN RESULT IN SERIOUS ACCIDENTS

IMPORTANT

After use, remove supplied lifting strop(s) and/or dee shackles and dispose.

Unit Overview

DTP04(-Ex) AND DTP05(-Ex) UNITS

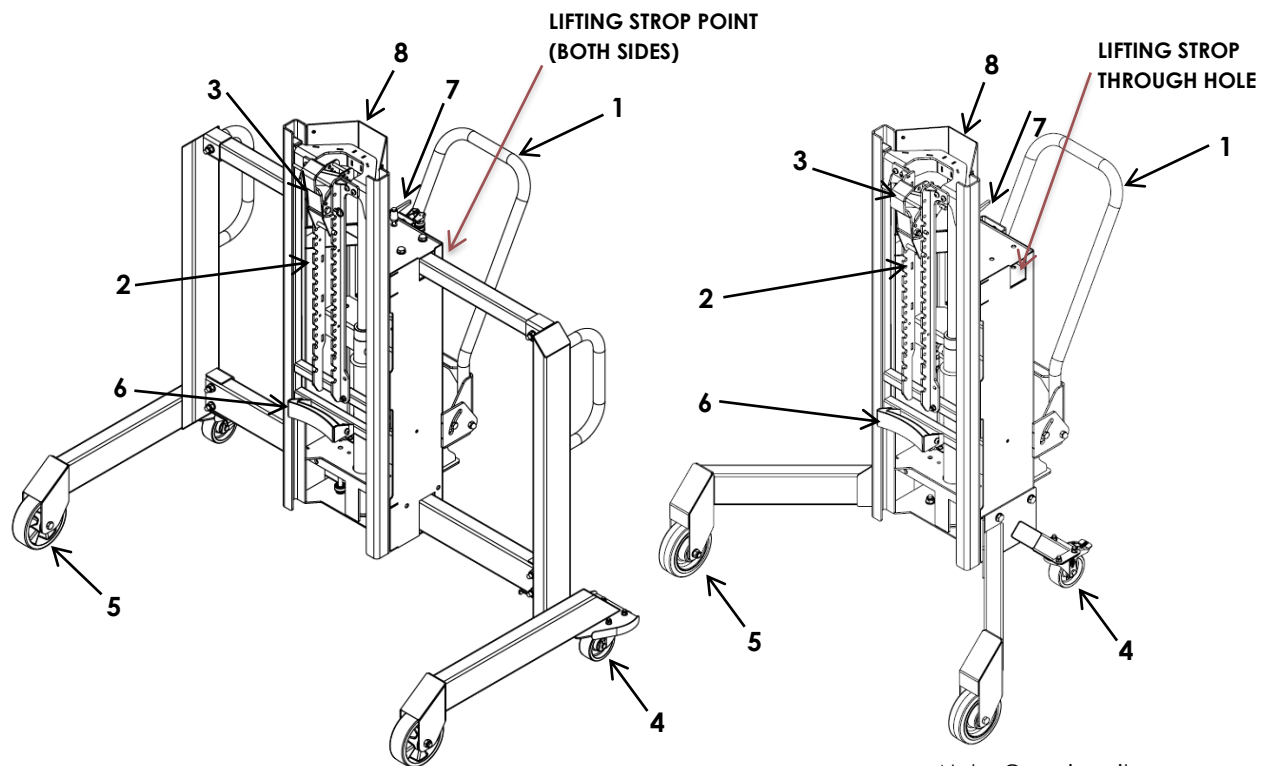

Note: Generic units shown

No.	Function
1	Steering/Pump Handle
2	Rack
3	Drum Catch
4	Real Wheel with Brake (x2)
5	Front Wheel (x2)
6	Thrust Pad
7	Lowering Valve
8	Polycarbonate Guard

Section II – Unit Description

The drum depalletiser is designed for lifting, lowering and transporting drums around the workplace as well as on and off of pallets. The instructions in this manual should be adhered to at all times, failure to do so could result in minor or serious injury to the operator and/or other personnel.

The unit incorporates enclosed, smooth geometry with rounded edges to ensure safe handling of the unit. The unit is fitted with a fully enclosed ram, which is operated from the rear of the unit to keep operator's limbs away from dangerous machinery movement.

THE SAFE WORKING LOAD (SWL) OF THIS UNIT IS 350KG

THIS UNIT IS DESIGNED FOR USE ON FLAT AND LEVEL FLOORS ONLY

ATEX CERTIFICATION

If the equipment supplied has (-Ex) in the product code, it has been certified by STS for use in Zone 1, 2, 21 and 22 areas for protection under constructional safety "c" and control of ignition source "b".

 **II 2 G D**

Ex cb IIB T4 Gb

Ex cb IIIB T135°C Db

IMPORTANT

Consideration must be taken by the end user to ensure safety and conformity within Ex zones between the unit and its surrounding environment including any interfaces which may occur.

Section III – Unit Operation

IMPORTANT

Before using this unit, operators must read and understand this instruction manual. Failure to observe the instructions in this manual will invalidate the warranty.

NOTE: Personal Protective Equipment (PPE) must be worn at all times, see 'Section I – Correct Use and Application' for more information.

Initial Setup and Connecting to Drums

Each depalletiser is fitted with a universal drum catch which is adjustable in both height (vertical) and reach (horizontal). This unique adjustability means that each lifter can handle a wide variety of drum types and sizes commonly found in the workplace.

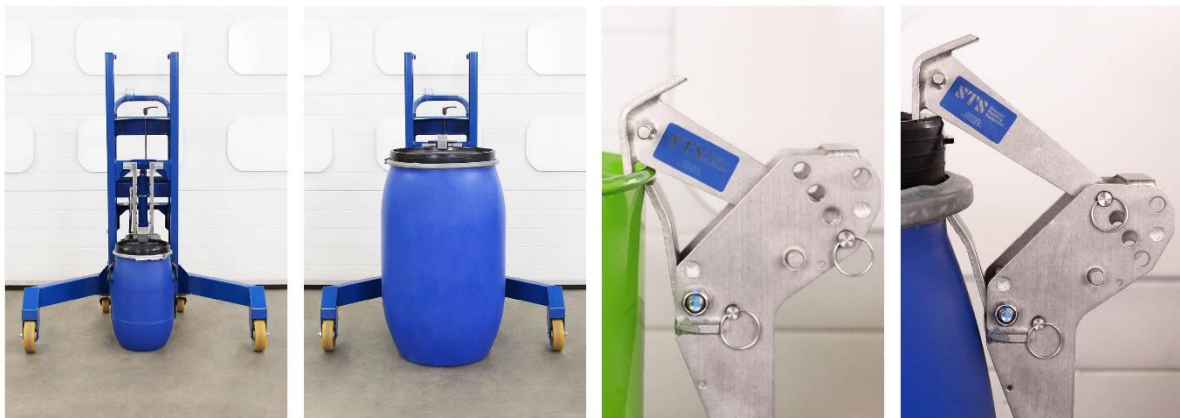

Note: Generic unit shown

- Ensure the rack is lowered fully so that all the vertical lift stroke is available; this is done by turning the lowering lever anticlockwise.

WARNING – DO NOT ROTATE THE LOWERING LEVER CLOCKWISE AS THIS MAY DAMAGE THE UNIT.

- There are teeth to which the drum catch can be secured, removing the front pin allows removal and height adjustment of the catch on the rack.
- Adjust the height of the catch so that it is positioned lower than the lip of the drum to be lifted, reinsert the pin to lock the catch in position.
- Manoeuvre the depalletiser using the handle, being sure to keep good posture. Operators should move gently while manoeuvring, whilst planning ahead in good time. Ensure that when not in use, the unit is parked on flat and level ground with the brakes engaged.
- Line up the lifter with the centreline of the drum.



- Lift the rack by operating the pump handle so that the catch rises above the top lip of the drum.
- Push the unit forward so that the top hook engages the drum.
- Lower the rack slowly by turning the lowering lever anti-clockwise ensuring that the top hook engages over the top lip of the drum and that the bottom toggle secures beneath the drum lip.
- The drum is now ready to be lifted.

Removing Drums from a Pallet

- Pump the hydraulic handle to raise the drum to the desired height.
- Remove drum from the pallet by slowly pulling the depalletiser away.
- When clear of the pallet and transporting the drum, keep the drum as low to the ground as is practical for transport.
- To place the drum down, simply turn the lowering lever anticlockwise. The rate at which the drum lowers is controlled by the amount that the lever is rotated.
- Once the drum is placed on the floor, or another pallet, continue to lower the rack until the catch goes slack, the operator can then reach forward and manually remove the top hook from the drum.
- If the catch is lowered too far; it will be not possible to unhook from the drum. In this instance raise the rack slightly by pumping the handle, the catch will then go slack and the top hook will be able to be unhooked.

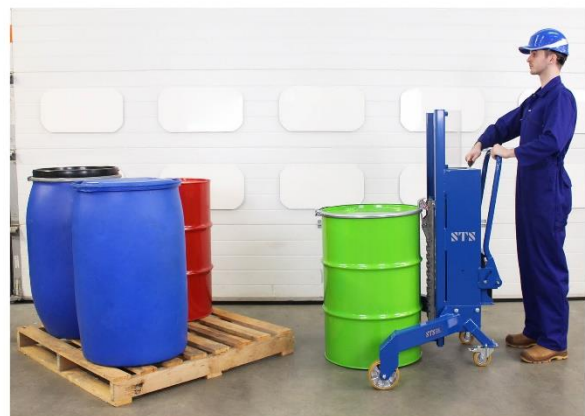

Note: Generic unit shown

Universal Drum Catch Variations

WARNING – DUE TO VARIATIONS IN THE MANUFACTURE OF DRUMS IT IS IMPORTANT THAT THE CORRECT HOOK POSITION IS SELECTED. FAILURE TO DO SO COULD RESULT IN THE CATCH DISCONNECTING FROM THE DRUM.

The universal drum catch has been designed so that a variety of positions can be used to fit different sized drums. Changing the hole that the top catch is located in increases the reach by a further 10mm by each hole placement. The top hook must always be placed in the shortest possible position. By removing the top pin, the top hook can be turned over so that the sticker is upside down. This gives the top hook a further 5mm of reach. Ensure that the pin is reinserted and secured before lifting. If required, the retractable support pad can be folded out to keep a drum in a more vertical orientation.



The following hole positions are for guidance only, every drum should be assessed individually and engaged with by following the instructions provided.

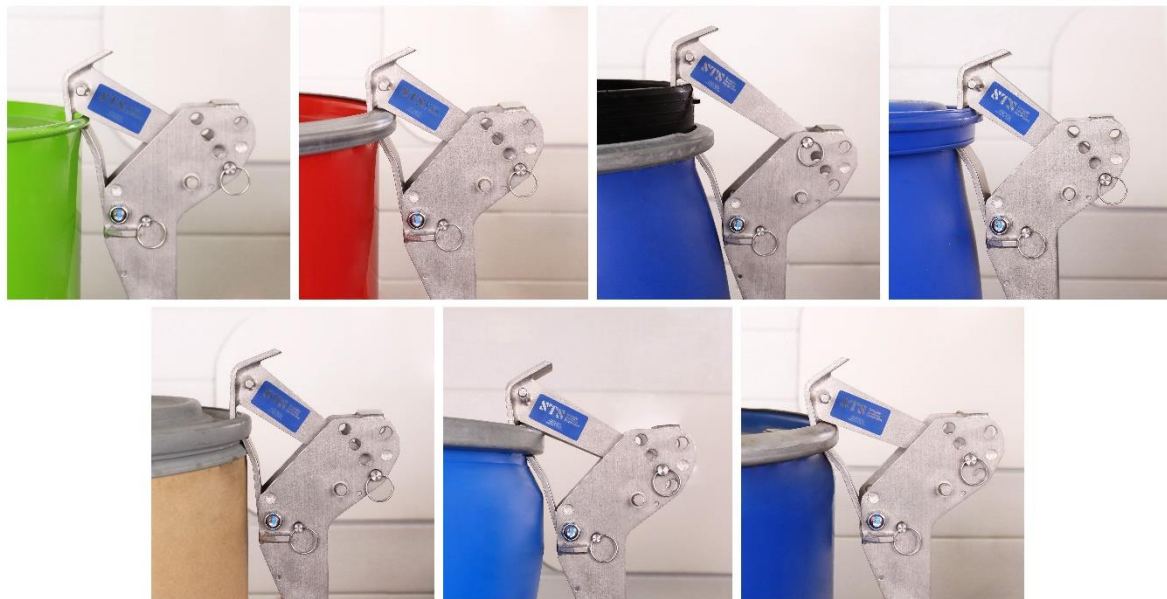

Top Hook Forward Reach Configuration Table

	Catch (Original)	Catch (Flipped)
Back hole (4th)	0mm	+5mm
3rd hole	+10mm	+15mm
2nd hole	+20mm	+25mm
Front hole (1st)	+30mm	+35mm

Section IV – Unit Maintenance, Troubleshooting and Consumables

Maintenance Checklist

The following servicing checklist indicates the operations to be performed and the respective intervals to be observed. Maintenance intervals are defined as:

- W = Every 50 service hours, at least weekly
- A = Every 1000 service hours, at least annually
- = Standard maintenance interval

During the run-in period – after approx. 100 service hours – the owner must check the wheel nuts/bolts and re-tighten if necessary.

NOTE: Personal Protective Equipment (PPE) must be worn at all times, see 'SECTION 1 – Correct Use and Application' for more information.

NOTE: Maintenance must only be performed by a suitably competent individual as decided by the company the equipment is intended for use with. All electrical maintenance must only be performed by qualified personnel.

	Weekly	Annually
Brakes and Toggle		
Test brakes and adjust if applicable/necessary	●	●
Check side-shift toggle grips cross beam (DTP04 only)	●	●
Chassis and Superstructure		
Inspect labels are legible and complete	●	●
Inspect all components for wear and damage		●
Check chassis and fixing connections for damage		●
Check guarding for damage and visibility, replace if necessary (see 'Consumables' for instructions)	●	●
If the unit is ATEX rated ensure that the earthing chains are in contact with the floor and that the wheels are clean and free from dirt and grime	●	●
Check unit for any damaged painted surfaces, touch up, if necessary, with approved touch up paint	●	●
Hydraulic Operations		
Test hydraulic lift and lower function for correct operation	●	●
Check hydraulic oil level via sight glass, top up if below half sight glass		●
Inspect hydraulic seals for damage and leaks		●
Replace hydraulic oil every two years (see 'Consumables' for instructions)		

Troubleshooting

When trying to locate a fault, proceed in the order shown in the table.

NOTE: Troubleshooting must only be performed by a suitably competent individual as decided by the company the equipment is intended for use with.

If, after carrying out the following remedial actions, the unit cannot be restored to operation, contact the manufacturer's technical helpline. In order for customer services to react quickly and specifically to the fault, the following information is essential:

- Unit serial number
- Description of error
- Unit product name
- Current location / Company

Fault	Reason/Action
Unit does not lift	Unit overloaded, note safe working load of unit
Unit does not lift to full stroke	Pump is short of oil. Ensure rod is at bottom of stroke and top-up/refill with hydraulic oil. Shell Tellus 22 or equivalent, half sight glass
Oil leaking from top of hydraulic cylinder, around chromed rod	Replace hydraulic cylinder seals
Oil leaking from tank filler point	Filler bung damaged or unit over filled with oil
Load lowering unintentionally	Ensure lowering lever is in the closed position

Consumables

All unit consumables are available from STS. The unit must be fitted with original STS consumables unless otherwise stated. Any deviation from non-original consumables may result in injury to personnel or damage to the unit and will invalidate the warranty.

Oil Replacement

STS manual pump units are factory-equipped with Shell Tellus 22 oil for the hydraulic system. It is recommended to use as stated or an equivalent when replacing hydraulic oil.

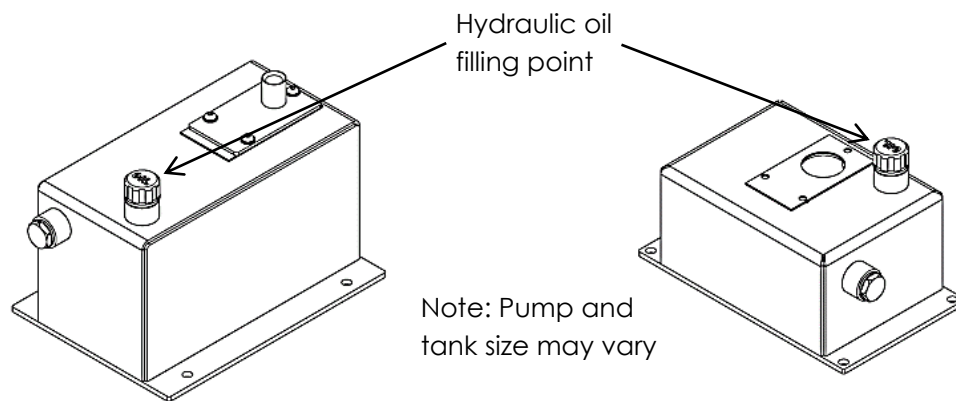

When replacing oil, fill oil to the line or to the middle of the sight glass. Operate all unit functions to their full extents. Return unit head to its lowest position and recheck the oil level, top up if required.

Touch Up Paint

Approved touch up paint should be used on any damaged painted surfaces, the surface should be rust free before painting with a non-aluminium based paint. STS use RAL 5010 for their blue paint.

Polycarbonate Guarding Replacement

The polycarbonate guarding should be replaced if damaged, cracked or visibility is reduced. These are available from STS.

To replace the polycarbonate guard, isolate the unit in a safe area, then proceed as follows:

- Remove the four rivets located in each corner and remove the old guard.
- On the new polycarbonate guard, peel back the protective film along all long edges.
- Position the new polycarbonate guard so that it fits inside the four tabs and use the existing holes to drill through with a 6mm drill bit.
- Reinsert the screw rivets to secure the new polycarbonate guard in place.

Wheel Replacement

Wheels should be replaced if damaged, cracked, or delaminated. These are available from STS.

For safety instructions refer to 'Lifting the Unit' in 'Section I – Correct Use and Application'

To replace the front wheels, jack up the leg or front of the unit for DTP08 models by 10mm so that one wheel is clear of the floor. Unbolt the wheel and remove it from the unit. Replace the wheel ensuring that the wheel bushes are re-fitted into the wheel prior to re-bolting. Repeat this process for the other leg or side. If removing the front castor for DTP08 models as well as the wheel, the unit will need to be jacked up high enough to allow the castor to be removed from underneath the lifter body. When low level legs are fitted with pallet roller wheels, the 20mm diameter wheel pin will need to be removed. To do this, remove the button head bolt and hammer out the pin.

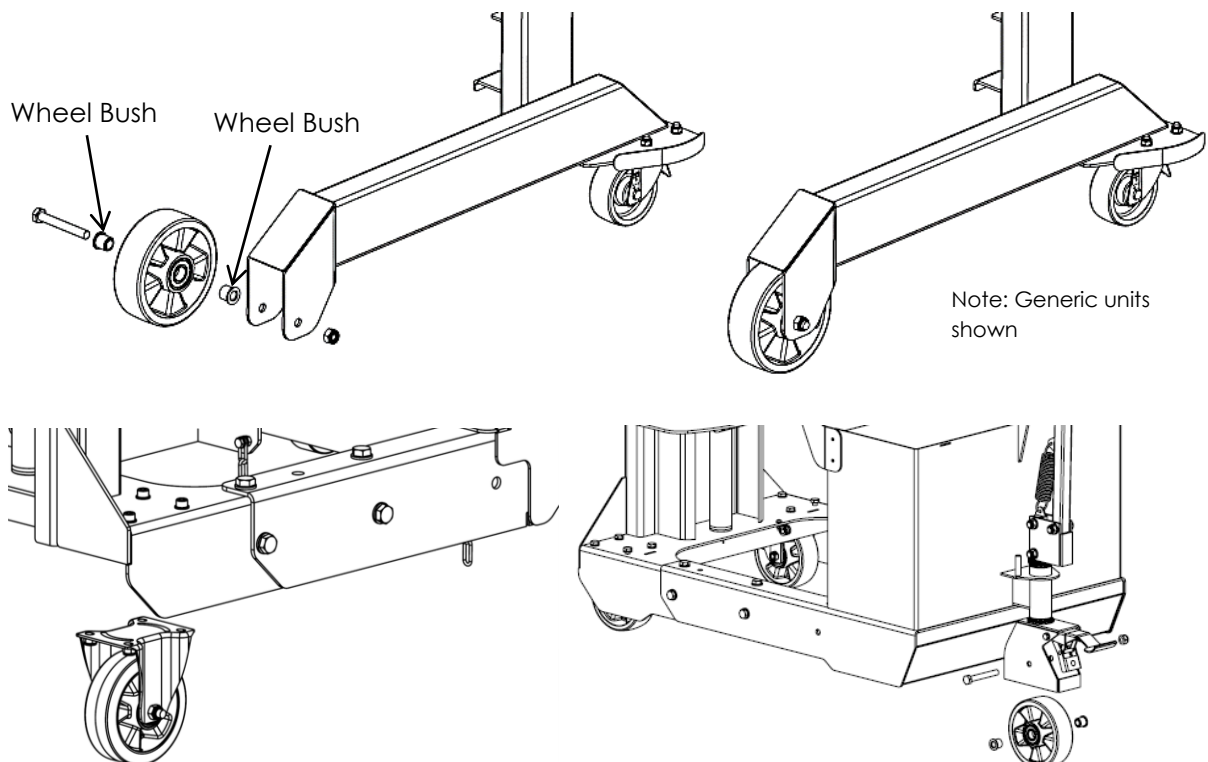

Use the same procedure as previously mentioned to replace the rear castors, ensuring that the wheel bushes are re-fitted in the wheel prior to re-bolting. For DTP08 models, the rear wheel used for steering will need to be jacked up high enough to allow it to be removed from the castor.

WARNING – DO NOT JACK THE UNIT MORE THAN NECESSARY AS UNIT MAY BECOME UNSTABLE

Section V - Technical Specification

General Arrangement

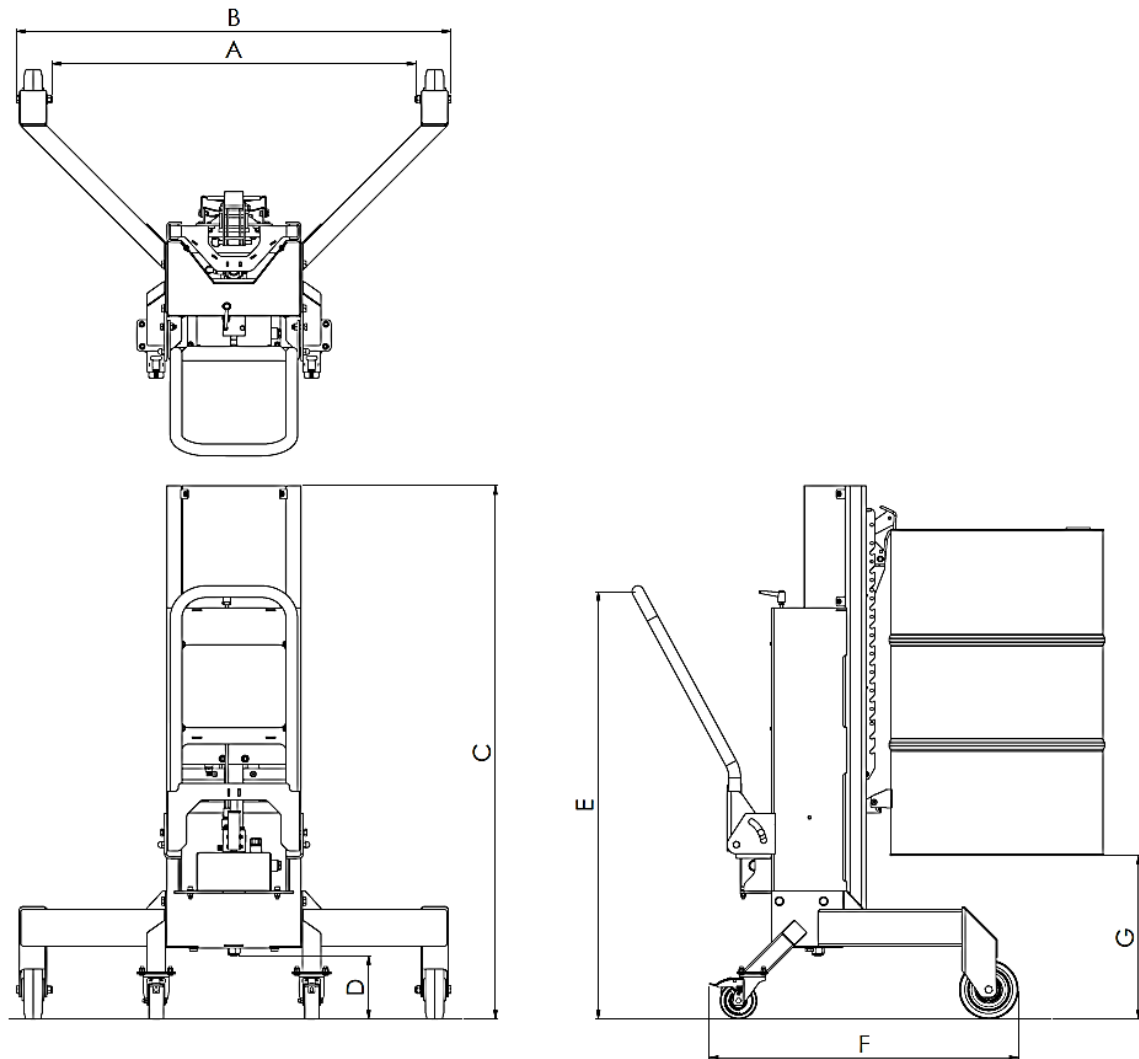

NOTE: ALL DIMENSIONS +/- 5MM.

Designation	Description	Dimension (mm)
A	Straddle	985
B	Maximum Width	1190
C	Maximum Height	1448
D	Clearance	172
E	Handle Height (centre of stroke)	1160
F	Unit Length	840
G	Distance under 205L drum	420

SWL 350kg **Net Mass** 94kg

Section VI - Decommissioning the Unit

If the unit is to be out of service for more than a month, e.g. for commercial reasons, it must be stored in a frost-free and dry room. All necessary measures must be taken before, during and after decommissioning as described hereafter. Decommissioning and recommissioning must only be performed by a suitably competent individual as decided by the company the equipment is intended for use with.

NOTE: Personal Protective Equipment (PPE) must be worn at all times, see 'Section I – Correct Use and Application' for more information.

Prior to Decommissioning

- Thoroughly clean the unit.
- Test the brakes (if applicable).
- Check the hydraulic oil and replenish if necessary (if applicable).
- Fully charge then disconnect the battery. Charge the battery every 2 months to protect from long term "non-use" damage (if applicable).
- Apply a thin layer of oil or grease to any non-painted mechanical components.

Final Decommissioning and Disposal

Final decommissioning or disposal of the unit must be performed in accordance with the regulations of the country of use. In particular, regulations governing the disposal of batteries, fuels and electronic and electrical systems must be observed. The unit must only be disassembled by trained personnel.

Recommissioning

- Reconnect the battery, first ensuring that the battery undamaged (if applicable).
- Follow the annual servicing check list located in 'Maintenance Checklist'.
- Follow the pre-start checklist located in 'Pre-start Inspections'.

Safety Tests to be Performed at Intervals and After Unusual Incidents.

Perform a safety check in accordance with national regulations. The unit must be inspected at least annually or after any unusual event by a qualified inspector. The inspector shall assess the condition of the unit from purely a safety viewpoint, without regard to operational or economic circumstances.

For further help contact STS:

Technical Support Line: +44 (0) 1736 851050

In the interest of all concerned it is essential that equipment of our manufacture is used only for the purposes for which it has been designed and it must be used in accordance with the instructions which are supplied.