

# Operating Instructions

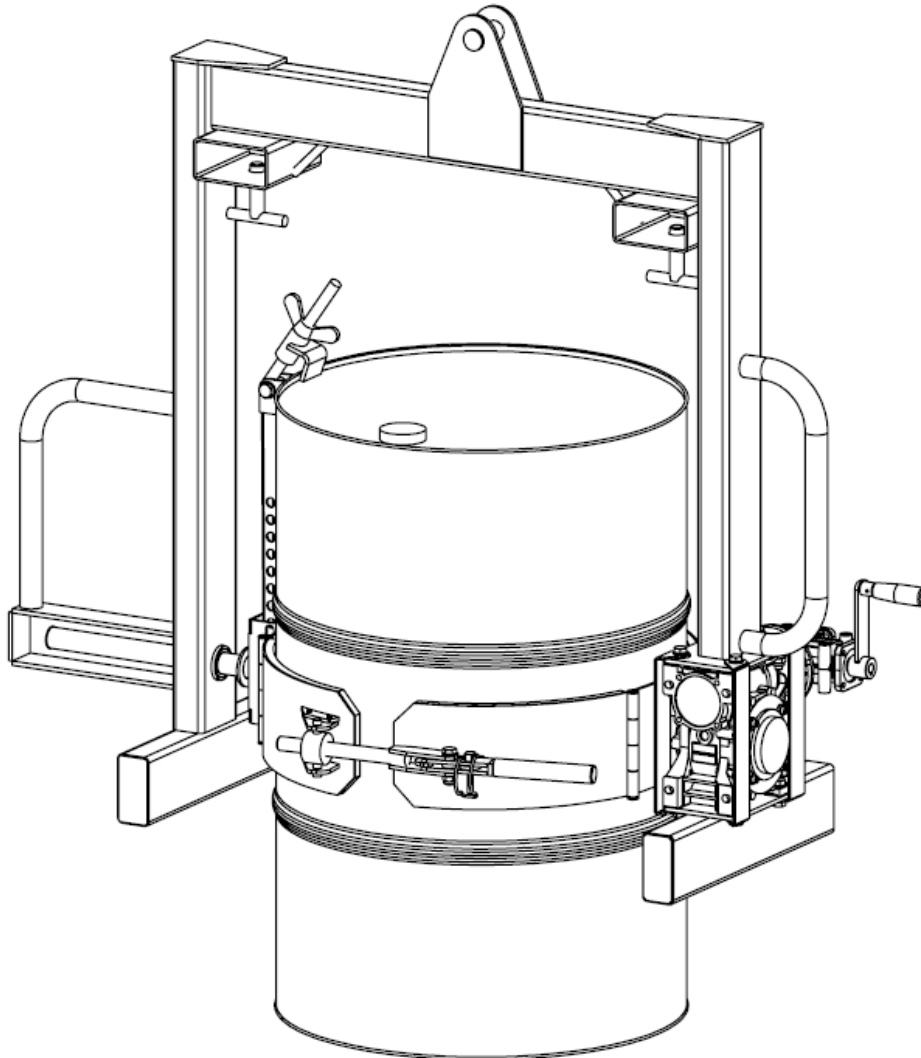

DRU02-FB

Fixed Band Overhead Drum Rotator

Bespoke Handling Equipment Ltd.  
Leedstown  
Hayle  
Penzance  
TR27 6DS

E-mail: [sales@sts-trolleys.co.uk](mailto:sales@sts-trolleys.co.uk)

Tel: +44 (0)1736 851050

Fax: +44 (0)1736 851023

<b>Section I – Correct Use and Application</b> .....	<b>3</b>
<b>Section II – Unit Description</b> .....	<b>6</b>
<b>Section III – Unit Operation</b> .....	<b>7</b>
Clamping the Drum.....	7
Rotating the Drum .....	8
<b>Section IV – Unit Maintenance</b> .....	<b>9</b>
Maintenance Checklist.....	9
Trouble Shooting .....	9
<b>Section V - Technical Specification</b> .....	<b>10</b>
Main Assembly Overview .....	10
Main Assembly Bill of Materials .....	11
Clamping Band Overview .....	12
Clamping Band Bill of Materials.....	12
General Arrangement .....	13
<b>Section VI - Decommissioning the Unit</b> .....	<b>14</b>
Final De-commissioning and Disposal .....	14
Safety Tests to be performed at Intervals and after Unusual Incidents.....	14

# Section I – Correct Use and Application

## General

The unit described in the present operating instructions is designed for lifting, lowering and transporting load units. It must be used, operated and serviced in accordance with the present instructions. Any other type of use is beyond the scope of application and can result in damage to personnel, the unit or property.

## Correct Application

### NOTE:

The maximum load must not be exceeded.  
The load must be lifted by the attachment provided by the manufacturer.  
Correct applications of this unit are as follows:

- Lifting and lowering of loads.
- Transporting lowered loads.
- Rotating loads.

## Approved Application Conditions

- Operation in industrial and commercial environments
- Permissible temperature range 5°C to 40°C
- Operation only on secure, level surfaces with sufficient capacity
- Operation only on routes that are visible and approved by the proprietor

## Proprietor Responsibilities

For the purposes of the present operating instructions the "proprietor" is defined as any natural or legal person who either uses the unit himself, or on whose behalf it is used. In special cases (e.g. leasing or renting) the proprietor is considered the person who, in accordance with existing contractual agreements between the owner and user of the unit, is charged with operational duties. The proprietor must ensure that the unit is used only for the purpose for which it is intended and that there is no danger to life and limb of the user and third parties. Furthermore, accident prevention regulations, safety regulations and operating, servicing and repair guidelines must be followed. The proprietor must ensure that all users have read and understood these operating instructions.

### NOTE:

Failure to comply with the operating instructions shall invalidate the warranty. The same applies if improper work is carried out on the unit by the customer or third parties without the permission of the manufacturer.

## Adding Attachments and/or Accessories

The mounting or installation of additional equipment which affects or enhances the performance of the unit requires written permission of the manufacturer. Local authority approval may also need to be obtained. Local authority approval does not however constitute the manufacturer's approval.

## Safety Regulations for the Operation of the Unit

### User authorisation

The unit may only be used by suitably trained personnel, who have demonstrated to the proprietor, or his representative that they can drive and handle the loads and have been authorised to operate the unit by the proprietor or his representative.

### User's rights, obligations and responsibilities

The user must be informed of his duties and responsibilities and be instructed in the operation of the unit and shall be familiar with the operating instructions. The user shall be afforded all due rights. Safety shoes must be worn for pedestrian units.

### Unauthorised use of unit

The user is responsible for the unit during the time it is in use. The user must prevent unauthorised persons from driving or operating the unit. Do not carry passengers or lift other people.

### Damage and faults

The supervisor must be immediately informed of any damage or faults to the unit or attachment. Units which are unsafe for operation (e.g. wheel or brake problems) must not be used until they have been rectified.

### Repairs

The user must not carry out any repairs or alterations to the unit without the necessary training and authorisation to do so. The user must never disable or adjust safety mechanisms or switches.

### Hazardous area

#### **WARNING! Risk of accidents / injury in the hazardous area of the unit.**

The hazardous area is defined as the area in which a person is at risk due to unit movement, lifting operations, the handler (e.g. forks or attachments) or the load itself. This also includes areas which can be reached by falling loads or lowering operating equipment.

- Instruct unauthorised people to leave the hazardous area
- Give a warning signal with plenty of time for people to leave
- If unauthorised personnel are still within the hazardous area stop the unit immediately

### Safety devices and warning labels

Safety devices, warning signs and warning instructions in the present operating instructions must be strictly observed.

### Travel routes and work areas

Only use lanes and routes specifically designated for unit traffic. Unauthorised third parties must stay away from work areas. Loads must only be stored in places specifically designated for this purpose. The unit must only be operated in work areas with sufficient lighting to avoid danger to personnel and materials. Additional equipment is necessary to operate the unit in areas of insufficient lighting.

### Type of loads to be carried

The operator must make sure that the load is in a satisfactory condition. Loads must always be positioned safely and carefully. Use suitable precautions to prevent parts of the load from tipping or falling down. Prevent liquid loads from sloshing out.

## Safety Regulations for Operation

### Types of loads to be carried

The operator must make sure that the load is in a satisfactory condition. Loads must always be positioned safely and carefully. Only lift loads as specified for the unit.

## Unit Operation

### WARNING!

#### Unsecured and incorrectly positioned loads can cause accidents

Before lifting a load unit the user must make sure that it has been correctly positioned and does not exceed the unit's capacity.

- Instruct other people to move out of hazardous area of the unit. Stop working with the unit if people do not leave the hazardous area
- Only carry loads that have been correctly secured and positioned. Used suitable precautions to prevent parts of the load from tipping or falling down
- Damaged loads must not be transported
- Never exceed the maximum load capacity of the unit
- Never stand underneath a raised load handler
- Do not stand on the load handler
- Do not lift other people on the load handler

### WARNING!

#### Risk of accidents and damage to components

All modifications to the unit, in particular safety mechanisms, are prohibited. The operating speeds of the unit must not be increased under any circumstances.

### NOTE:

Only original spare parts have been certified by the manufacturer. To ensure safe and reliable operation of the unit, use only the manufacturer's spare parts.

## Operational Safety and Environmental Protection

The checks and servicing operations contained in this chapter must be performed in accordance with the intervals as indicated in the servicing checklists.

## Maintenance Safety Regulations

### Maintenance Personnel

The unit should only be serviced and repaired by a competent individual as selected by the company the equipment is intended for use with.

### Lifting and jacking up

### WARNING!

#### Lifting and jacking up the unit safely

In order to raise the unit, the lifting gear must only be secured to the points specially provided for this purpose. You may only work under a raised load handler if they have been secured with a sufficiently strong chain. In order to raise and jack up the unit safely, proceed as follows:

- Jack up the unit only on a level surface and prevent it from moving accidentally
- Always use a jack with sufficient capacity. When jacking up the unit, take appropriate measures to prevent it from slipping or tipping over (e.g. wedges, wooden blocks, etc.)
- In order to raise the unit, the lifting gear must only be secured to the point specially provided for this purpose

### Consumables and Used parts

### CAUTION!

#### Consumables and Used parts are an environmental hazard

Used parts, oils and fuels must be disposed of in accordance with the relevant environmental protection regulations. To change the oil, contact the manufacturer's customer service department, who have been specially trained for this task.

- Note the safety regulations when handling these materials

## Servicing and Inspection

Thorough and expert servicing is one of the most important requirements for the safe operation of the unit. Failure to perform regular servicing can lead to unit failure and poses a potential hazard to personnel and equipment.

### WARNING!

The application conditions of a unit have considerable impact on the wear of the service components.

### Lifting the Unit

### WARNING!

#### Improper lifting by crane can result in serious accidents

The use of unsuitable lifting gear can cause the unit to crash when being lifted by crane. Prevent the unit from striking other objects when it is being raised and avoid any involuntary movements. If necessary secure the unit with guide ropes. The strap point on the mast is for loading the unit with lifting gear.

- The unit should only be handled by people who are trained in using lifting slings and tools
- Do not walk into or stand in a hazardous area
- Always use lifting gear with sufficient capacity
- Always attach the slings to the prescribed strap points and prevent them from slipping

### WARNING!

#### Accidental movement during transport

Improper fastening of the truck and mast during transport can result in serious accidents.

- Loading must be carried out by special trained staff in accordance with recommendations contained in Guidelines BS EN 12640:2001. In each case correct measurements must be made and appropriate safety measures adopted
- The unit must be securely fastened when transported on a lorry or trailer
- Use only tension belts or tie-down straps or with sufficient strength

### Lifting the Unit

#### Requirements

- Unit positioned securely

#### Tools and Material Required

- Lifting gear

#### Procedure

- Secure Lifting hook to the strap point

The unit can now be lifted.

### Securing the unit for transport

#### Tools and Material Required

- Tension belts/tie down straps

#### Procedure

- Move the unit onto the transporting truck
- Unit positioned securely

The unit can now be transported.

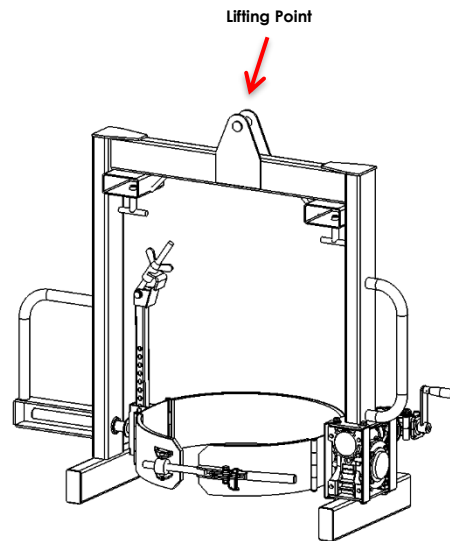

## Section II – Unit Description

The DRU02-FB is an overhead drum rotator designed to be used with an overhead hoist, crane or forklift. It is designed to support and rotate drums. The unit uses a manually rotated gearbox.

The drum should be stood vertically; the unit can then approach the drum with the band open. The back of the band is then pushed flush to the drum and then the two doors fastened around. Once the drum is secured it can then be lifted, transported and rotated.

The DRU02-FB is designed to pick up and rotate 200 – 220 litre steel or plastic drums with a diameter of between 560 – 600mm.

The unit incorporates enclosed, smooth geometry with rounded edges to ensure safe handling of the unit.

**The Safe Working Load (SWL) of this unit is 350kg**

## Section III – Unit Operation

### IMPORTANT

Before using the DRU02-FB operators must read and understand this instruction manual. Failure to observe the instructions in this manual will invalidate the warranty.

The Maximum weight of drum that the unit should be used to pick up is **350kg**.

### Clamping the Drum

- Attach the rotator to a lifting device by the designated lifting point.
- Lift and manoeuvre the rotator around the drum so that the drum sits within the drum clamping band.
- The front doors are then closed around the drum.
- The over centre clamp is hooked onto the opposite door and the lever operated until the clamp locks in position.
- If the tension on the clamp needs adjusting this is done by turning the clamp in the adjusting nut before hooking into the opposite door.
- The drum clamping band should be tight enough that the drum starts to show deflection. When this is achieved, the safety pin must be placed in the clamp handle to prevent accidental release of the drum.
- The rim clamp must be connected to the top lip of the drum. The height can be set by removing the 'R' clip, which is close to the right-hand pivot, and removing the pin. The rim clamp arm can now be set to the correct height to suit the drum size. Ensure that the top of the drum rim clamp arm is positioned under the top rim of the drum. Whilst this is being held in place the top swivelling clamp can be positioned over the rim of the drum. You can now clamp the two together by screwing down the butterfly nut. You should check that the top drum lip is securely clamped between the two sections of the drum rim clamp.
- Replace the clamping arm adjustment pin through the body of the rotator bracket.
- Replace the locking 'R' pin.
- **IMPORTANT** - Check all steps have been completed correctly before you lift the drum off the floor. If you are in any doubt then contact the STS Technical support line +44 1736 851 050

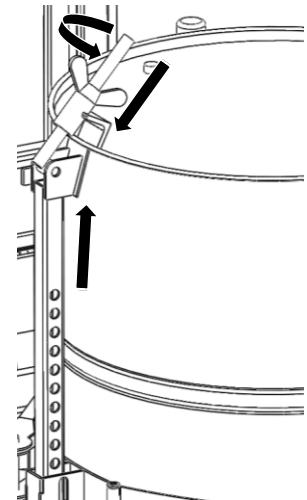

## Rotating the Drum

The Maximum weight of drum that the unit should be used to pick up is **350kg**.

### *Requirements*

- The back band is in the horizontal orientation
- Load is secure in an upright position within the drum clamping band
- Load does not exceed specified SWL

### *Procedure*

- With the drum lifted sufficiently, the operator rotates the handle attached to the gearbox to rotate the drum. If the operator stops rotating the handle at any point the drum will remain in its current position.



## Section IV – Unit Maintenance

### Maintenance Checklist

The follow servicing checklist indicates the operations to be performed and the respective intervals to be observed. Maintenance intervals are defined as:

- W = Every 50 service hours, at least weekly
- A = Every 1000 service hours, at least annually
- = Standard maintenance interval

<b>Chassis and Superstructure</b>		<b>W</b>	<b>A</b>
1	Check labels are legible and complete	•	•
2	Check chassis and screw connections for damage		•
3	Check the condition of the drum clamping assembly and grease the threads with copper ease.	•	•

<b>Agreed Performance Level</b>		<b>W</b>	<b>A</b>
1	Carry out a test run with rated load, if necessary with customer specified load		•

**OPERATORS SHOULD REPORT ANY DEFECTS ON THE DRU02-FB TO THE APPROPRIATE PERSON**

### Trouble Shooting

When trying to locate a fault, proceed in the order shown in the table.

#### **NOTE:**

Troubleshooting must only be performed by competent personnel. If after carrying out the following remedial action the unit cannot be restored to operation, contact the manufacturer's technical helpline listed at the end of this manual.

In order for STS to be able to react quickly and specifically to the fault, the follow information is essential:

- Mixer serial number
- Description of error
- Mixer product name
- Current location / Company

<b>Possible Cause</b>	<b>Action</b>
Unit does not lift Drum	Drum clamp assembly not correctly tensioned
Gearbox handle hard to turn	Unit overloaded
Gearbox handle hard to turn	Drum band not secured centrally on drum

## Section V - Technical Specification

### Main Assembly Overview

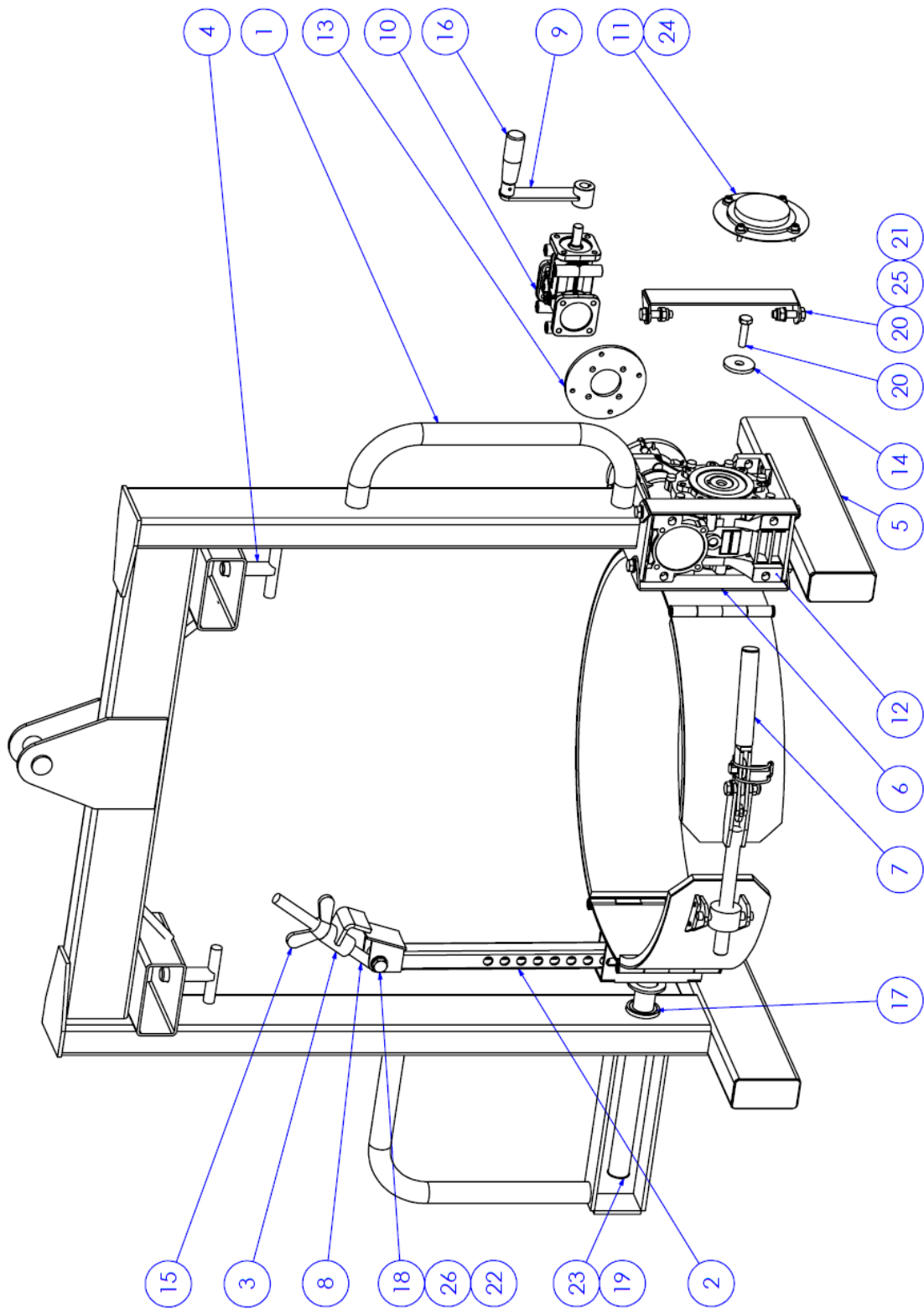

## Main Assembly Bill of Materials

ITEM NO.	DESCRIPTION	PRODUCT CODE	QTY.
1	DRU02 FRAME	002203	1
2	DRUM CLAMP ADJUSTER	002496	1
3	DRUM CLAMP ANGLE	002498	1
4	FORK CLAMP	002363	2
5	GEARBOX FOOT	002204	1
6	GEARBOX STRAPS	002205	4
7	OVERHEAD ROTATOR FIXED BAND	012448	1
8	THREADED DRUM CLAMP	002501	1
9	TRANSFER BOX HANDLE AND BUSH	009280	1
10	90 DEGREE TRANSFER BOX (1(C) TO 2(A) RATIO)	009266	1
11	GEARBOX OUTPUT COVER NMRV75	011262	1
12	NMRVP 75 60:1 RATIO 35MM SHAFT	001255	1
13	ADAPTOR PLATE NMRVP 75 TO BEVEL BOX	001377	1
14	NMRV-P75 SHAFT RETAINING WASHER	003777	1
15	M16 WING NUT	002502	1
16	FOLD AWAY HANDLE	001284	1
17	41 OD X 30.5 ID 60 LG ACETAL BUSH	001749	1
18	HEX BOLT - M12 X 60 - A2	M12 X 60 - A2	1
19	HEX SET SCREW - M8 X 16 - A2	M8 X 16 - A2	1
20	HEX SET SCREW - M10 X 40 - BZP	M10 X 40 - BZP	9
21	NYLOC NUT - M10P - BZP	M10P - BZP	8
22	NYLOC NUT - M12P - A2	M12P - A2	1
23	REAIR WASHER - 8 - 32 - A2	REPAIR WASHER - 8 - 32 - A2	1
24	SOCKET HEAD CAP SCREW - M6 X 20 - BZP	Z 31 - M6 X 20	4
25	WASHER - 10 - BZP	WASHER - 10 - BZP	16
26	WASHER - 12 - A2	WASHER - 12 - A2	2

## Clamping Band Overview

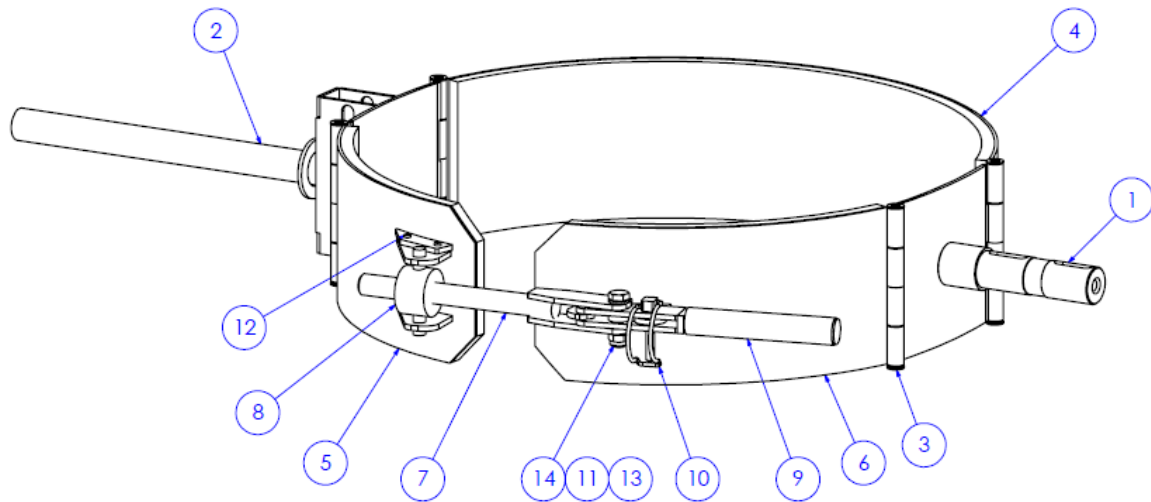

## Clamping Band Bill of Materials

ITEM NO.	DESCRIPTION	PRODUCT CODE	QTY.
1	GEARBOX SHAFT PLATE	002189	1
2	FREE PIVOT END PLATE	002207	1
3	STRAP PIN	002198	4
4	BACK BAND	001515	1
5	FRONT DOOR LH	001520	1
6	FRONT DOOR RH	001519	1
7	TIE ROD	001516	1
8	TRAPEZOIDAL ROUND NUT	001517	1
9	HANDLE	001518	1
10	10MM PIPE LYNCH PIN	004580	1
11	WASHER - 10 - A2	10 - A2	2
12	BUTTON HEAD SCREW - M6 X 12 - A2	M6 X 12 - A2	2
13	HEX BOLT - M10 X 45 - A2	M10 X 45 - A2	1
14	NYLOC NUT - M10P - A2	M10P - A2	1

## General Arrangement

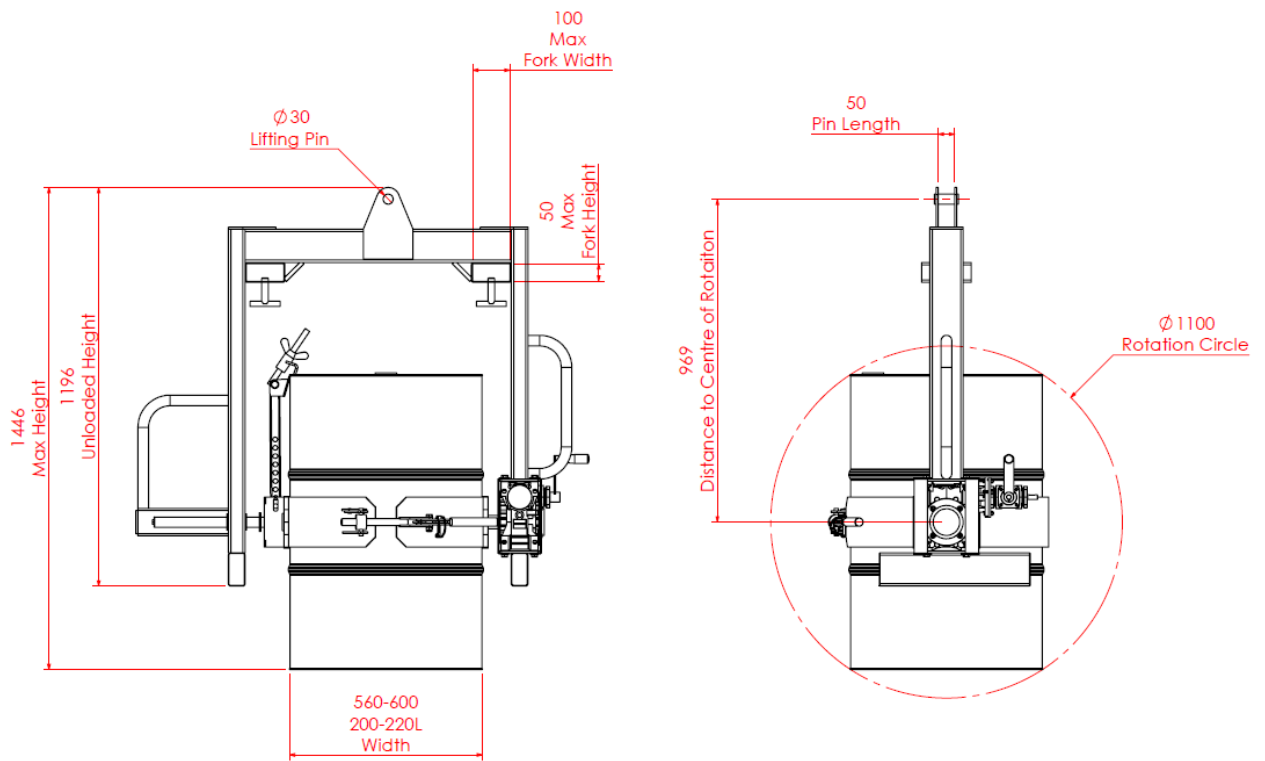

**SWL.** 350kg

**Drum Range.** 200-220L Drums

**Net Mass.** 75kg

**Drum Diameter Range:** 560-600mm

## Section VI - Decommissioning the Unit

If the unit is to be out of service for more than a month, e.g. for commercial reasons, it must be stored in a frost-free and dry room. All necessary measures must be taken before, during and after decommissioning as described hereafter.

### Prior to decommissioning

- Thoroughly clean the unit.
- Apply a thin layer of oil or grease to any non-painted mechanical components.

### Final De-commissioning and Disposal

Final de-commissioning or disposal of the unit must be performed in accordance with the regulations of the country of use. In particular, regulations governing the disposal of batteries, fuels and electronic and electrical systems must be observed.

The truck must only be disassembled by trained personnel.

### Safety Tests to be performed at intervals and after Unusual Incidents

Perform a safety check in accordance with national regulations.

The unit must be inspected at least annually or after any unusual event by a qualified inspector. The inspector shall assess the condition of the unit from purely a safety viewpoint, without regard to operational or economic circumstances.

For further help contact the Bespoke Handling Equipment:

**Technical Support Line: 44 (0) 1736 851050**

In the interest of all concerned it is essential that equipment of our manufacture is used only for the purposes for which it has been designed and it must be used in accordance with the instructions which are supplied.