

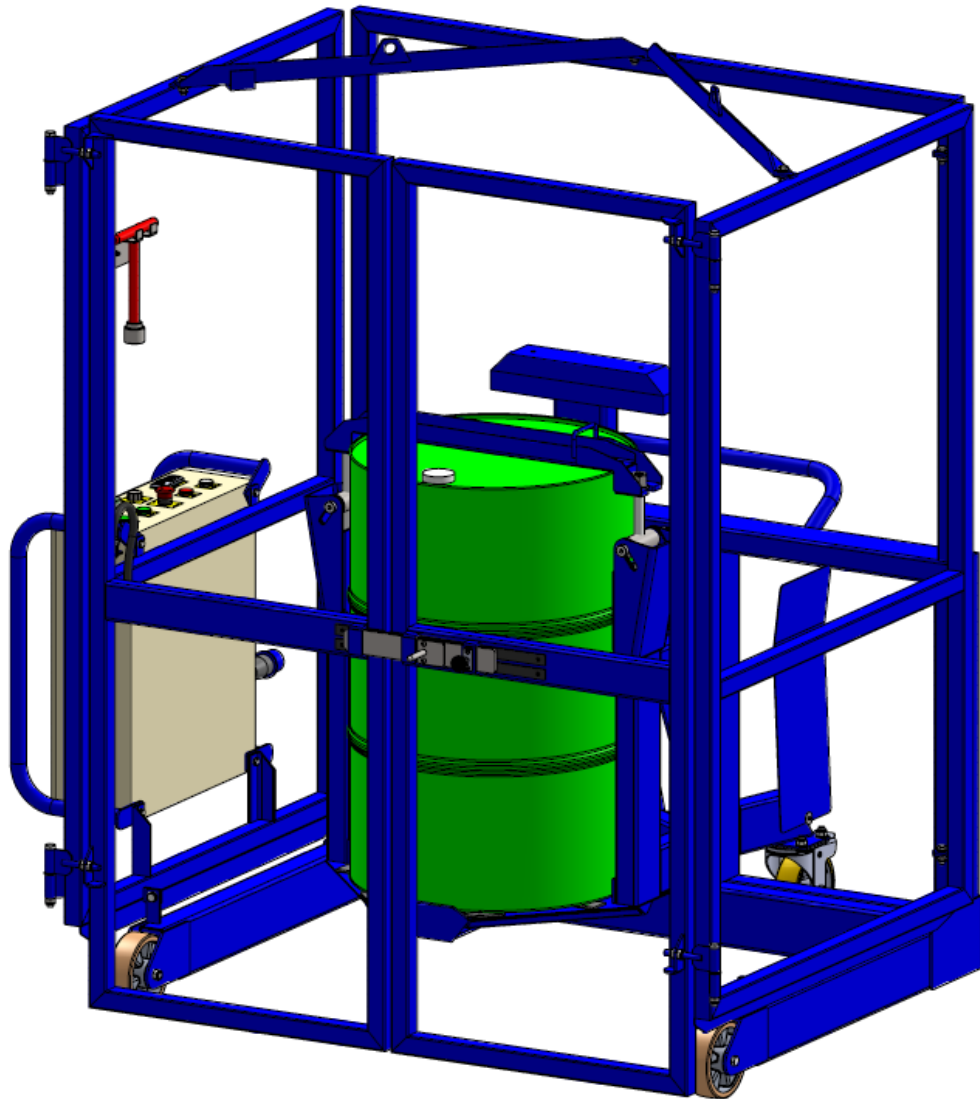

Bespoke
Handling
Equipment

Operating Instructions



DME01-230V-24RPM ELECTRIC DRUM MIXER

Bespoke Handling Equipment Ltd.
Leedstown
Hayle
Cornwall
United Kingdom
TR27 6DS

E-mail: sales@sts-trolleys.co.uk

Tel: +44 (0)1736 851050

Fax: +44 (0)1736 851023

Section I – Correct Use and Application	2
General	2
Foreseeable Misuse of the Unit.....	2
Approved Application Conditions.....	2
Proprietor Responsibilities	3
Adding Attachments and/or Accessories.....	3
Safety Regulations for the Operation of the Unit	3
Consumables and Parts.....	5
Ex Certified Units (if applicable)	5
Lifting the Unit	6
Lifting Points.....	7
Section II – Unit Description	8
Section III – Unit Operation	9
Positioning the Mixer.....	9
Pre-start Inspection.....	9
Loading the Mixer.....	10
Setting the Operation Timer.....	11
Off-centre Loads	11
Safety Features	12
Small Drum Adaptor (Optional Extra)	12
Section IV – Unit Maintenance, Troubleshooting and Consumables	13
Maintenance Checklist.....	13
Troubleshooting	15
Consumables.....	15
Section V - Technical Specification	16
General Arrangement	16
Section VI - Decommissioning the Unit	17
Prior to Decommissioning.....	17
Final Decommissioning and Disposal.....	17
Recommissioning.....	17
Safety Tests to be Performed at Intervals and After Unusual Incidents	17

Section I – Correct Use and Application

Only operation manuals written in English are the original instructions, versions provided in any other language then become a translation of the original instructions.

General

The unit described in the present operating instructions must be used, operated and serviced in accordance with the present instructions. Any other type of use is beyond the scope of application and can result in damage or injury to personnel, the unit or property. The unit described in the present operating instructions complies with all relevant directives and standards.

Foreseeable Misuse of the Unit

Personnel must take care when operating the unit. The following actions must be adhered to:

- The maximum safe working load (SWL) must not be exceeded.
- Do not travel with a raised load 500mm above the ground unless necessary.
- When manoeuvring the unit, do not exceed a speed of 1m/s (3.6km/h).
- When manoeuvring a raised load above 500mm, do not exceed a speed of 0.1m/s (0.36km/h).
- If applicable, do not over lower the head of the unit onto a platform, such as a mezzanine floor.
- Do not carry or lift other personnel.
- Do not stand or ride on the unit.
- Loads must be undamaged.
- Do not negotiate inclines unless otherwise stated.
- Do not stand underneath a raised load or within the confines of the unit during operation.
- The load must be lifted and/or mixed by the attachment provided.
- Do not alter the unit specification from original supply.
- Do not disable, remove or adjust safety mechanisms or switches.
- Observe all instruction decals applied to the unit.
- Do not leave the unit in direct sunlight.
- The manufacturer shall not be held liable in case of faults or accidents due to negligence, incapacity, installation by unqualified personnel or improper use.

Approved Application Conditions

- Operation in dry industrial and commercial environments.
- Permissible temperature range 5°C to 40°C.
- Lighting of at least 300 Lux.
- Altitudes not exceeding 2000m.
- Operation only on secure, level surfaces with sufficient capacity.
- Operation only on routes that are visible and approved by the proprietor.
- Operation in accordance with guidance stated within the operating instructions.
- The unit must be maintained in accordance with the maintenance schedule stated within the operating instructions.
- Appropriate personal protective equipment, PPE, must be worn at all times.

Proprietor Responsibilities

For the purposes of the present operating instructions the “proprietor” is defined as any natural or legal person who either uses the unit themselves, or on whose behalf it is used. In special cases (e.g. leasing or renting) the proprietor is considered the person who, in accordance with existing contractual agreements between the owner and user of the unit, is charged with operational duties. The proprietor must ensure that the unit is used only for the purpose for which it is intended and that there is no danger to life or limb of the user and third parties. Furthermore, accident prevention regulations, safety regulations and operating, maintenance and repair guidelines must be followed. The proprietor must ensure that all users have read and understood these operating instructions. The proprietor must perform an onsite risk assessment before the unit is put in to service.

IMPORTANT

Failure to comply with the operating instructions shall invalidate the warranty. The same applies if improper work is carried out on the unit by the proprietor or third parties without the permission of the manufacturer.

Adding Attachments and/or Accessories

The mounting or installation of additional equipment which affects or enhances the performance of the unit requires written permission of the manufacturer. Local authority approval may also need to be obtained. Local authority approval does not however constitute the manufacturer’s approval. An onsite risk assessment must then be carried out.

WARNING - ANY UNAUTHORISED MODIFICATIONS OR ADDITIONS TO THE UNIT SHALL INVALIDATE THE WARRANTY AND STS SHALL NOT BE LIABLE.

Safety Regulations for the Operation of the Unit

Operator authorisation

The unit may only be used by suitably trained personnel, who have demonstrated to the proprietor, or their representative that they can operate the unit safely and in accordance with the operating instructions.

Operator’s rights, obligations and responsibilities

The operator must be informed of their duties and responsibilities and be instructed in the operation of the unit and shall be familiar with the operating instructions. Operators must be provided the appropriate PPE as mentioned in the ‘Approved Application Conditions’ section of this manual.

Unauthorised use of unit

The operator is responsible for the unit during the time it is in use. The operator must prevent unauthorised persons from operating the unit.

Damage and faults

The proprietor must be immediately informed of any damage or faults to the unit or attachment. Units which are unsafe for operation must be quarantined until faults have been rectified and the unit deemed safe for operation.

Servicing and repairs

All unit parts and consumables are available from STS. The unit must be fitted with original STS parts and consumables unless otherwise stated. Any deviation from non-original parts and consumables may result in injury to personnel or damage to the unit and will invalidate the warranty. The operator must never disable, remove or adjust safety mechanisms or switches. The unit should only be serviced and repaired by a competent individual as selected by the company the equipment is intended for use with.

Safety devices and warning decals

Safety devices, warning decals and warning instructions in the operating instructions and on the unit must be strictly observed.

Travel routes and operational areas

Only use lanes and routes specifically designated for unit traffic. Unauthorised third parties must stay away from operational areas. The unit must only be operated in operational areas with sufficient lighting to avoid damage or injury to personnel, the unit or property. Additional equipment is necessary to operate the unit in areas of insufficient lighting.

Hazardous area of the unit

The hazardous area is defined as the area in which a person is at risk due to the unit itself or movement of the unit and/or load. This also includes areas which can be reached by falling loads. The operator must:

- Instruct unauthorised personnel to leave the hazardous area.
- Give a warning signal with plenty of time for personnel to leave.
- Stop all operations if unauthorised personnel are within or enter the hazardous area.

Travel conduct

The operator must adapt the travel speed to local conditions. The unit must be driven at slow speed when negotiating bends or narrow passageways, when passing through swing doors and at blind spots. Abrupt stopping (except in emergencies), rapid U turns and overtaking at dangerous or blind spots are not permitted. When not in use, the equipment should be parked in a safe location with the brakes engaged.

Travel visibility

The operator must look in the direction of travel and must always have a clear view of the route ahead. When transporting loads that affect visibility, a second person must safely assist the operator to observe the travel route.

Type of loads

The operator must make sure that the load is in a satisfactory condition. Loads must always be positioned safely and carefully. Use suitable precautions to prevent parts of the load and/or their contents from falling or spilling.

Cleaning

Cleaning of the unit depends on the environment that the unit is used in. It is recommended that the unit be cleaned daily if the unit comes into contact with aggressive substances such as chemicals, fertilizers, salt, etc. It is recommended to use detergent and a damp cloth to clean the body of the unit. Do not use flammable liquids to clean the unit. Do not clean the unit with pressurised water. If the unit is rated for Ex environments, the unit must be kept clean and dust free.

Personal protective equipment (PPE)

PPE must be worn at all times. A minimum of safety shoes must be worn while operating the unit. Safety shoes, safety glasses, protective gloves, hearing protection and protective overalls are to be worn when carrying out servicing, repairs and maintenance. When operating overhead loads, a hard hat must be worn. End user health and safety procedures and best practices should be followed in addition to the above recommendations.

Consumables and Parts

Environmental hazards

Parts and oils must be disposed of in accordance with the relevant environmental protection regulations.

Hydraulic hoses (if applicable)

Brittle hydraulic hose lines cause accidents. Hairline cracks in the hydraulic lines can cause injury and infection. The hydraulic hoses should only be serviced or replaced by a competent individual as selected by the company the equipment is intended for use with. It is the responsibility of the proprietor to maintain the hydraulic hoses.

Lift chains (if applicable)

Incorrectly cleaned chains can cause accidents. Lift chains are safety-critical parts. They must not contain any serious contamination. Lift chains and pivot pins must always be clean. Never clean chains with high pressure steam jet cleaners, cold or chemical cleaning agents. It is recommended to clean the chains and pivot pins in an unloaded state with a citrus cleaner to remove dirt and grime followed by the application of a PTFE based industrial grade chain lubrication spray or food grade lubrication spray.

NOTE: For more consumable information refer to 'Section IV – Unit Maintenance, Troubleshooting and Consumables'.

Ex Certified Units (if applicable)

Operational hazards

Processing of liquids or suspensions (mixing or stirring, filling or draining) can give rise to ignition risks due to static electricity including the risk of propagating brush discharges. The processing of liquids or suspensions is the responsibility of the end user.

Environmental hazards

Care should be taken by the end user to ensure collisions do not occur between the unit and its surrounding environments which may create a potential ignition source.

Earthing chains

Ensure earthing chains are securely fitted and are in contact with the ground at all times, wheels should be kept clean and free from debris.

Electrically powered units

Care should be taken by the end user to ensure any electrical cables to and/or from the unit are kept away from travel areas where they may become entangled, damaged or be a trip hazard. Electrical cables must be kept dry, clean and be routinely checked as stated in the maintenance procedures. Any cracked or damaged electrical cables must be reported immediately and the unit be put out of service until resolved.

Lifting the Unit

Lifting the unit safely

In order to raise the unit safely, including off a pallet, proceed as follows:

- The unit must be on a level surface to prevent it from moving accidentally.
- The lifting gear must only be secured to the points designated for this purpose.
- Always use lifting gear with sufficient capacity.
- The unit should only be handled by qualified personnel who are trained in using lifting slings and tools.
- Do not walk into or stand under a raised unit.
- If necessary, secure the unit with guide ropes to aid when lifting the unit.

Jacking the unit safely

In order to jack up the unit safely, proceed as follows:

- The unit must be on a level surface to prevent it from moving accidentally.
- Always use a jack with sufficient capacity.
- The unit should only be handled by qualified personnel who are trained in using lifting slings and tools.
- When jacking up the unit, take appropriate measures to prevent it from moving, slipping or tipping over (e.g. wedges, wooden blocks, stops)

WARNING - IMPROPER LIFTING CAN RESULT IN SERIOUS ACCIDENTS

Securing the unit for transport

In order to transport the unit safely, proceed as follows:

- The unit must be securely fastened when transported on a lorry/trailer.
- The lorry/trailer must have fastening rings.
- Use wedges to prevent the unit from moving.
- Use only tension belts or tie-down straps with sufficient strength.

WARNING - IMPROPER FASTENING OF THE UNIT DURING TRANSPORT CAN RESULT IN SERIOUS ACCIDENTS

IMPORTANT

After use, remove supplied lifting strop(s) and/or dee shackles and dispose.

Lifting Points

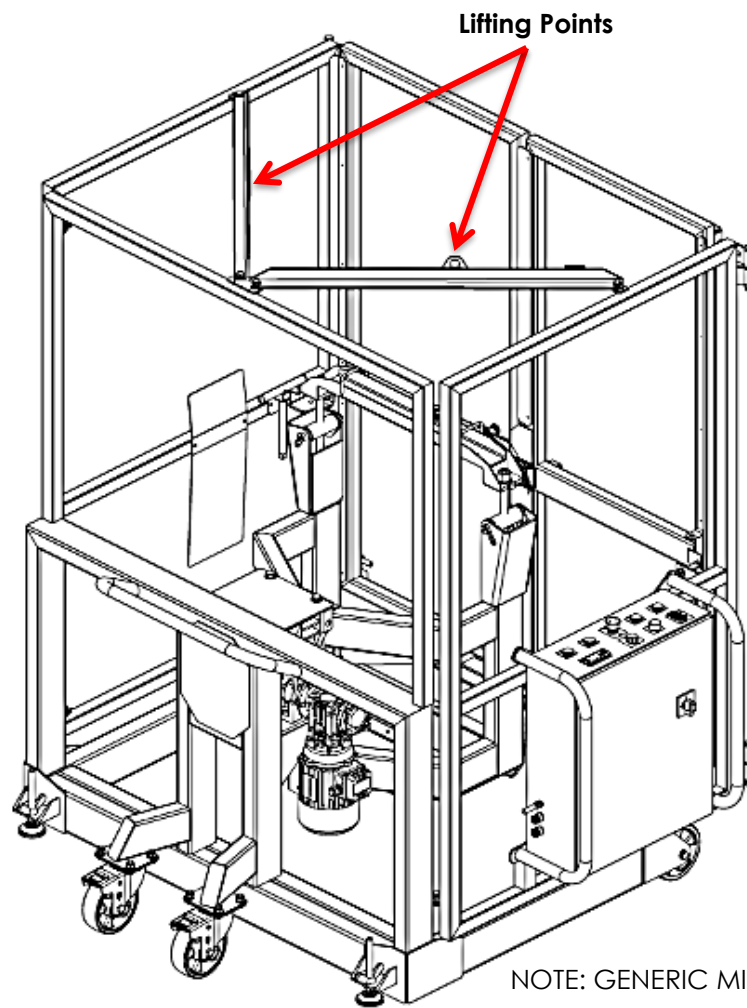

NOTE: GENERIC MIXER SHOWN

Section II – Unit Description

The drum mixer is a four-wheeled unit designed for use on flat ground. The unit is designed to be operated only in a stationary position, the unit features wheels to ease positioning only.

The intended purpose of this unit is to accept, secure and rotate drums, end over end. The rotational speed can be adjusted by the operator to suit the application. The unit is designed to accept drums of between 200-220 litres. The drums must have a maximum diameter of 600mm and be between 860mm-1010mm in height. The drum mixer will output a maximum rotational speed of 24 RPM. Drums with an offset load, or viscous contents, will result in a lower RPM.

The small drum adaptor is an optional extra available with this product. The small drum adaptor fits inside the mixer head and allows drum of up to 500mm in diameter and between 100mm-900mm in height to be mixed.

An emergency stop button has been incorporated which will rapidly cut out all the electrical functions when pressed. The drum mixer will not start unless the gates are closed, if the gates are opened whilst the unit is operating then the mixer will stop to ensure the safety of the operator and other personnel.

The unit has been designed with smooth geometry including rounded edges. The rotating head of the unit is fully enclosed in guarding which is compliant with BS EN 13857:2019 to ensure safe handling of the mixer. Ergonomic controls ensure fatigue-free operation. For electric versions, a digital timer displays the remaining mixing time which can be set by the operator.

THE SAFE WORKING LOAD (SWL) OF THIS UNIT IS 300KG

DO NOT ATTEMPT TO ROTATE THE MIXER HEAD UNLOADED

Section III – Unit Operation

IMPORTANT

Before using this unit, operators must read and understand this instruction manual. Failure to observe the instructions in this manual will invalidate the warranty.

NOTE: Personal Protective Equipment (PPE) must be worn at all times, see 'Section I – Correct Use and Application' for more information.

Positioning the Mixer

- Ensure lifting straps are removed after transport and before putting the unit into operation.
- Position the mixing unit in a position close to a mains power supply and ensure that the gates can be opened fully for drum loading.
- Lock the two rear park brakes **(1)** to ensure the unit does not move during the mixing process.
- The unit is fitted with two rear jacking screw feet **(2)**. These should be screwed down so that the rear castors are slightly off the floor. The lock nut can then be tightened to lock the screw in place. The jacking feet help to stop the mixer vibrating during use.
- Plug the mains lead into a suitable power supply. Ensure that the cable is positioned away from any areas that would cause the cable to be a trip hazard.

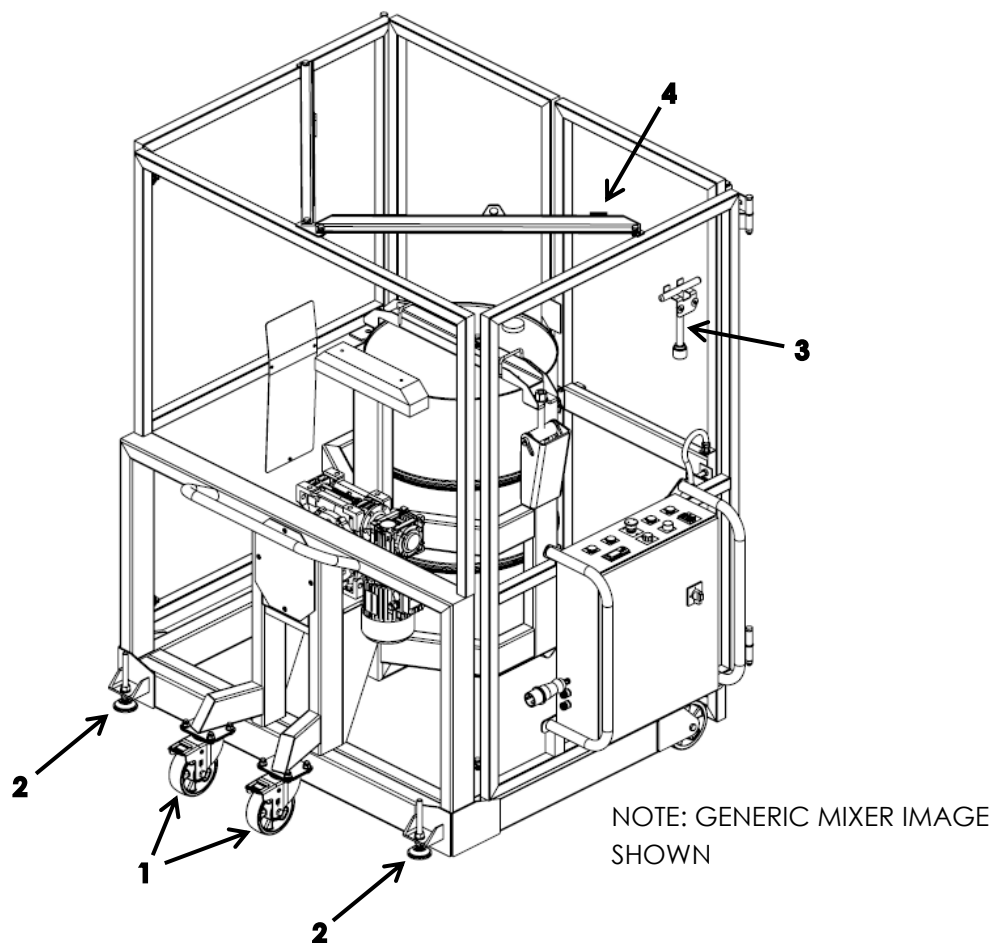

Pre-start Inspection

Before operating the drum mixer:

- Check the whole of the mixer for signs of damage.
- Check that the markings and labels are present, clean and legible.
- Check the gearbox shaft and top clamp bar screw threads for wear and damage.

Loading the Mixer

- Unscrew the two screw clamps using the T-handle tool **(3)** provided and remove the top clamp bar. The T-handle tool is stored in a bracket secured to the inside of the mesh guarding. The top clamp bar can be hooked onto the storage hook on the left-hand side of the guard rail **(4)**.
- The drum can then be loaded onto the mixer base plate using any drum handling unit that will fit within the confines of the drum mixer. (All STS Drum Depalletisers are compatible with the drum mixer)
- The top clamp bar is then lifted and placed centrally on top of the drum.
- The two screw clamps are then lifted up so that they slot into the recesses in the top clamp bar.
- Ensure that the clamp screws are vertical and the top clamp plate is centralised on the drum.
- The clamp screws should then be tightened to secure the drum using the t-handle tool provided. Ensure that the screw clamps are tightened evenly so the top clamp bar remains level on the drum and the pins move to the top of the slots on each of the vertical supports.

WARNING - ENSURE THAT THE T-HANDLE TOOL IS REMOVED FROM THE CLAMPING ASSEMBLY AND STORED IN THE BRACKET ON THE MESH GUARDING BEFORE MIXING.

- Close the gate at the front of the unit. Pull the black latching lock with your right hand and slide the stainless-steel bolt **(5)** across to lock the gates together. Let go of the latching lock to lock the bolt in position.
- Turn the power switch on **(6)**. The power on light **(7)** should be illuminated.
- Turn the rotation speed control **(8)** to the desired rotation speed.
- Press the green start button on the start/stop controls **(9)** on the main panel to start the mixing cycle, the rotation light **(10)** will illuminate during operation. The timer is initially set for 30 minutes, if you wish to adjust the mix time follow the instructions for setting the operation timer.
- The timer will count down until the set time has elapsed. Alternatively, you can press the red stop button on the start/stop controls **(9)**.
- The drum will stop in any position, so you will need to press the green docking button **(11)** to allow the drum to rotate into the vertical. The docking light **(12)** will illuminate during this process.
- The drum needs to be in the vertical position for unloading and loading.
- The gate can now be opened and the drum removed in reverse order of the drum loading procedure.

Setting the Operation Timer

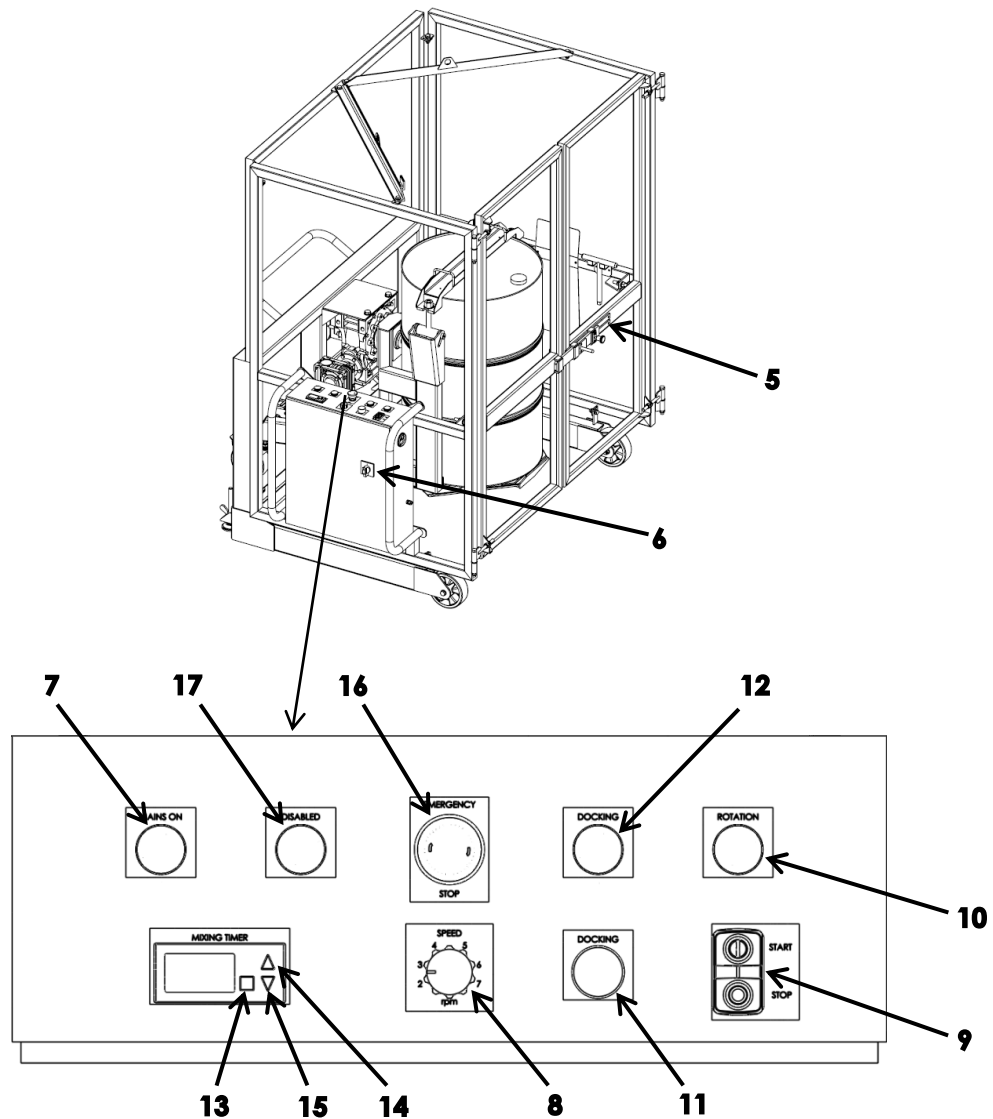

- Press the set button **(13)** once. The display will start flashing. Use the up **(14)** and down **(15)** arrows to set the desired mixing time in hours and minutes.
- Press the set button **(13)** to confirm the mixing time. The mixing time figures should now stop flashing.

Off-centre Loads

- Care should be taken to ensure the centre of mass of the drum is as close to the centreline on the shaft as possible. The maximum off-centred load for a 200-220 litres drum is 50% of the drums volume, value based on contents with a specific gravity of no more than 1200kg/m³. Off-centred loads may result in a reduction in mixing speed.
- If a drum outside of these loading conditions is attempted to be mixed, it may trip the circuit breaker in order to protect the motor and other components due to an excessive current draw.

Safety Features

- There is an emergency stop button **(16)** on top of the panel. If this is pressed the rotation will stop and the disabled light **(17)** will illuminate. Rotate clockwise to reset.
- If the gate is opened whilst the unit is operating, the unit will stop. The disabled light **(17)** will illuminate.

Small Drum Adaptor (Optional Extra)

- The small drum adaptor fits underneath the top clamp bar and has a two-position clamping brace. Depending on the diameter of drum to be mixed, the clamping brace can be removed from the small drum adaptor assembly and rotated 180 degrees.
- The height of the small drum adaptor clamp bar can be adjusted by removing the two over centre clamping pins and selecting the desired holes. The appropriate hole should allow the pins on the vertical bars to protrude through the holes in the base plate of the mixer whilst the clamping brace is sat flush on top of the drum, as shown below.

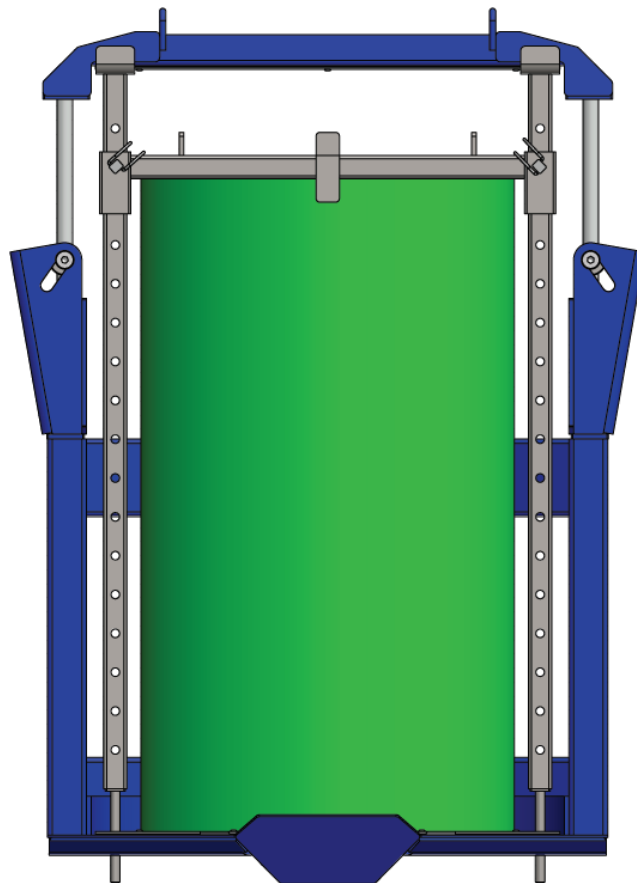

- The same procedure as previously mentioned can then be used to clamp the small drum adaptor on top of the drum. Ensure that the drum cannot move around before mixing.

Section IV – Unit Maintenance, Troubleshooting and Consumables

Maintenance Checklist

The follow servicing checklist indicates the operations to be performed and the respective intervals to be observed. Maintenance intervals are defined as:

- W = Every 50 service hours, at least weekly
- A = Every 1000 service hours, at least annually
- = Standard maintenance interval

During the run-in period – after approx. 100 service hours – the owner must check the wheel nuts/bolts and re-tighten if necessary.

NOTE: Personal Protective Equipment (PPE) must be worn at all times, see 'Section I – Correct Use and Application' for more information.

NOTE: Maintenance must only be performed by a suitably competent individual as decided by the company the equipment is intended for use with. All electrical maintenance must only be performed by qualified personnel.

Braking (if applicable)		W	A
1	Test brakes, ensure when engaged the unit cannot be moved	●	●

Travel		W	A
1	Check wheels for wear and damage		●
2	Clean wheels if required	●	●

Chassis and Superstructure		W	A
1	Check doors and/or covers for damage	●	●
2	Check labels are legible and complete	●	●
3	Check chassis and fixings connections for damage		●
4	Check screw threads on mixer head for damage, re-grease if necessary		●
5	Check gearbox, shaft and head (load handler) for wear and damage		●
6	Check shaft nut for signs of movement	●	●

Electrical System (DME01/04 and DME01/04-Ex Model Only)		W	A
1	Test warning and safety devices in accordance with operating instructions	•	•
2	Test unit controls are functioning and in particular that the stop/emergency stop is functioning quickly and effectively	•	•
3	Check electric wiring for damage (insulation damage, connections). Make sure wire connections are secure. (WARNING: Ex Enclosure must have power isolated it reaches the control box and not just by turning the power switch to off)		•
4	Inspect electrical contacts to ensure they are clean, tight and free from corrosion or heat damage from arcing. (WARNING: Ex Enclosure must have power isolated it reaches the control box and not just by turning the power switch to off)		•

Ex Checks (if applicable, -Ex models only)		W	A
1	Check wheels for dirt and grime, clean if required	•	•
2	Clean unit, ensure dirt and dust free	•	•
3	Ensure earthing chains are fitted and in contact with the ground	•	•
4	Check unit for any damaged painted surfaces. Touch up, if necessary, with an approved touch up paint	•	•
5	Ensure earthing strip is attached to the mixer head and contacts with drum when loaded	•	•

OPERATORS SHOULD REPORT ANY DEFECTS ON THE UNIT TO THE APPROPRIATE PERSON, IF IN ANY DOUBT OR YOU NEED REPLACEMENT PARTS, PLEASE CONTACT THE STS TECHNICAL SUPPORT LINE.

Troubleshooting

When trying to locate a fault, proceed in the order shown in the table.

NOTE: Troubleshooting must only be performed by a suitably competent individual as decided by the company the equipment is intended for use with.

If, after carrying out the following remedial action, the unit cannot be restored to operation, contact the manufacturer's technical helpline. In order for customer services to react quickly and specifically to the fault, the following information is essential:

- Unit serial number
- Unit product name
- Description of error
- Current location / Company

Unit does not start (Electrically powered)

Possible Cause	Action
Emergency stop engaged	Reset the emergency stop button
Isolator set to 'Off'	Set isolator switch to 'On'
Unit unplugged	Check unit is plugged in to power supply

Mixer does not rotate

Possible Cause	Action
The load exceeds the SWL	Reduce mass of load
Off-centre load too high	Reduce off-centred load
Load incorrectly secured	See instructions for loading the drum
Emergency stop engaged (if applicable)	Reset emergency stop button(s)
Air pressure too low (pneumatic units only)	Check air supply achieves minimum required
Air flow too low (pneumatic units only)	Check air supply achieves minimum required

Load cannot be clamped

Possible Cause	Action
Drum outside useable size range	Refer to specification stated in 'Unit Description'

Unit cannot be moved

Possible Cause	Action
Rear parking brakes are engaged	Release the rear parking brakes
Jacking feet engaged with floor	Disengage jacking feet

Consumables

Approved touch up paint should be used on any damaged painted surfaces, the surface should be rust free before painting with a non-aluminium based paint. STS use RAL 5010 for their blue paint.

Section V - Technical Specification

General Arrangement

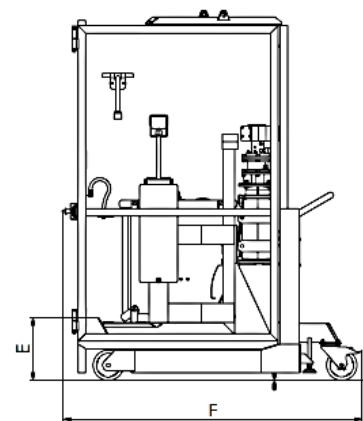
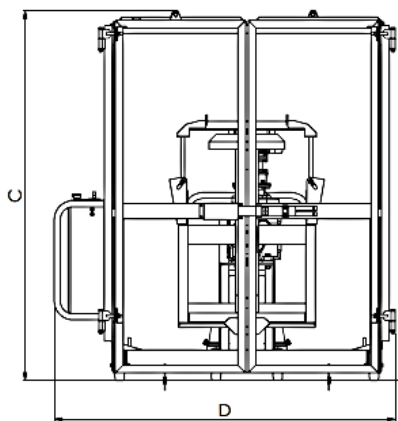
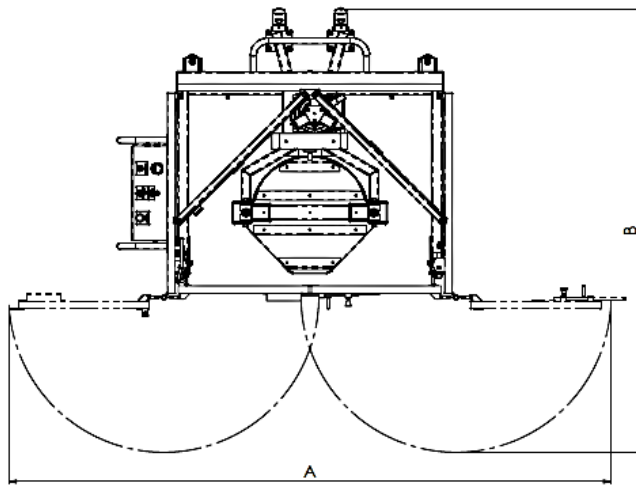

NOTE: GENERIC IMAGE SHOWN, ALL DIMENSIONS +/- 10MM.

Designation	Description	Dimension (mm)
A	Maximum Width (doors open)	3180
B	Maximum Length (doors open)	2350
C	Unit Height	1950
D	Unit Width (doors closed)	1820
E	Loading Height	350
F	Unit Length	1590

SWL. 300kg

System Voltage. 230V

Max Noise Level. 79dbA

Drum Range. 200-220 litres (max diameter - 600mm), (max height 860mm-1010mm)

Net Mass. 345kg +/-5kg

Nominal Power. 550W

Section VI - Decommissioning the Unit

If the unit is to be out of service for more than a month, e.g. for commercial reasons, it must be stored in a frost-free and dry room. All necessary measures must be taken before, during and after decommissioning as described hereafter. Decommissioning and recommissioning must only be performed by a suitably competent individual as decided by the company the equipment is intended for use with.

NOTE: Personal Protective Equipment (PPE) must be worn at all times, see 'Section I – Correct Use and Application' for more information.

Prior to Decommissioning

- Thoroughly clean the unit.
- Test the brakes (if applicable).
- Check the hydraulic oil and replenish if necessary (if applicable).
- Fully charge then disconnect the battery. Charge the battery every 2 months to protect from long term "non-use" damage (if applicable).
- Apply a thin layer of oil or grease to any non-painted mechanical components.

Final Decommissioning and Disposal

Final decommissioning or disposal of the unit must be performed in accordance with the regulations of the country of use. In particular, regulations governing the disposal of batteries, fuels and electronic and electrical systems must be observed. The unit must only be disassembled by trained personnel.

Recommissioning

- Reconnect the battery, first ensuring that the battery undamaged (if applicable).
- Follow the annual servicing check list located in 'Maintenance Checklist'.
- Follow the pre-start checklist located in 'Pre-start Inspections'.

Safety Tests to be Performed at Intervals and After Unusual Incidents.

Perform a safety check in accordance with national regulations. The unit must be inspected at least annually or after any unusual event by a qualified inspector. The inspector shall assess the condition of the unit from purely a safety viewpoint, without regard to operational or economic circumstances.

For further help contact STS:

Technical Support Line: +44 (0) 1736 851050

In the interest of all concerned it is essential that equipment of our manufacture is used only for the purposes for which it has been designed and it must be used in accordance with the instructions which are supplied.